



## OROVILLE PLANNING COMMISSION

Council Chambers  
1735 Montgomery Street  
Oroville, CA. 95965

**June 23, 2022**  
**REGULAR MEETING**  
**6:00 PM**  
**AGENDA**

---

### PUBLIC ACCESS AND PARTICIPATION

To view the meeting or provide comment, please see the options below. All comments emailed will be provided to the Members for their consideration.

#### To View the Meeting:

1. Watch our live feed <https://www.youtube.com/channel/UCAoRW34swYI85UBfYqT7IbQ/>
1. Watch via Zoom  
<https://zoom.us/j/99508232402?pwd=aThZc1BsUG9sWnhNYnlwZHZZdFFrQT09>  
Meeting ID: 995 0823 2402  
Passcode: **17351735**
3. Listen via telephone  
Telephone: 1-669-900-9128  
Meeting ID: 995 0823 2402  
Passcode: **17351735**

#### To Provide Comment to the Board:

1. Email before the meeting by 2:00 PM your comments to [publiccomment@cityoforoville.org](mailto:publiccomment@cityoforoville.org)
2. **Attend in person**

**If you would like to address the Commission at this meeting, you are requested to complete the blue speaker request form (located on the wall by the agendas) and hand it to the City Clerk, who is seated on the right of the Council Chamber. The form assists the Clerk with minute taking and assists the Mayor or presiding chair in conducting an orderly meeting. Providing personal information on the form is voluntary. For scheduled agenda items, please submit the form prior to the conclusion of the staff presentation for that item. The Commission has established time limitations of three (3) minutes per speaker on all items and an overall time limit of thirty minutes for non-agenda items. If more than 10 speaker cards are submitted for non-agenda items, the time limitation would be reduced to one and a half minutes per speaker. **(California Government Code §54954.3(b)).** Pursuant to Government Code Section 54954.2, the Commission is prohibited from taking action except for a brief response from the Council or staff to statements or questions relating to a non-agenda item.**

### CALL TO ORDER / ROLL CALL

Commissioners: Glenn Arace, Marissa Hallen, Natalie Sheard, Warren Jensen, Vice Chairperson Wyatt Jenkins, Chairperson Carl Durling

## OPEN SESSION

Pledge of Allegiance

## PUBLIC COMMUNICATION - HEARING OF NON-AGENDA ITEMS

This is the time to address the Commission about any item not listed on the agenda. If you wish to address the Commission on an item listed on the agenda, please follow the directions listed above.

## CONSENT CALENDAR

Consent calendar **items** are adopted in one action by the Commission. Items that are removed will be discussed and voted on immediately after adoption of consent calendar items.

### 1. APPROVAL OF THE MINUTES

The Planning Commission may approve the minutes of March 24, 2022 and May 26, 2022.

#### RECOMMENDATION

Approve the minutes of March 24, 2022 and May 26, 2022

## PUBLIC HEARINGS

The Public Hearing Procedure is as follows:

- Mayor or Chairperson opens the public hearing.
- Staff presents and answers questions from Council
- The hearing is opened for public comment limited to three (3) minutes per speaker. In the event of more than ten (10) speakers, time will be limited to one and a half (1.5) minutes. Under Government Code 54954.3, the time for each presentation may be limited.
- Public comment session is closed
- Commission debate and action

### 2. OZONE ENTERTAINMENT - USE PERMIT #22-02 FOR 1726 MONTGOMERY STREET

Minor Use Permit UP#22-02 for Ozone Entertainment, a new indoor recreational facility, including hatchet throwing, alcohol sales, and Segway and bicycle rentals.

#### RECOMMENDATION

**Recommend Adoption of the Notice of Exemption** as the appropriate level of environmental review in accordance with the California Environmental Quality Act (CEQA);

**Adopt** Use Permit #UP 22-03 including the recommended Findings and permit conditions, and

**Adopt** Resolution No. P2022-09: **A RESOLUTION OF THE OROVILLE PLANNING COMMISSION MAKING FINDINGS AND CONDITIONALLY APPROVING MINOR USE PERMIT UP22-03 FOR OZONE ENTERTINMENT, AN INDOOR COMMERCIAL RECREATIONAL FACILITY AT 1726 MONTGOMERY STREET (APN 012-028-013 & -015)**

**3. GENERAL PLAN AMENDMENT AND REZONE FROM PUBLIC-QUASI PUBLIC TO DOWNTOWN MIXED-USE OF 21 PARCELS FRONTIGN LINCOLN STREET, BRODERICK STREET, OAK STREET, AND STAFFORD STREET**

The Oroville Planning Commission may review and consider recommending that the City Council approve General Plan Amendment GPA 22-01 and Zoning Code Amendment ZC 22-03 for twenty-one parcels on Lincoln, Safford, Oak and Broderick. (APN's 012-021-008, -011, -012, -015, -018, -020, -021, -022, -023, -028, -029 AND APN's 012-028-003, -004, -005, -006, -007, -008, -009, -015, -016, AND APN 012-031-008).

**RECOMMENDATION**

**Certify the Notice of Exemption**

**Approve General Plan Amendment GPA 22-01**

**Adopt Zoning Change ZC 22-03**

**Adopt Resolution No. P2022-07 --** A RESOLUTION OF INTENTION BY THE OROVILLE PLANNING COMMISSION RECOMMENDING THE CITY COUNCIL ADOPT GENERAL PLAN AMENDMENT 21-04 AND ZONING CODE AMENDMENT ZC 22-03 TO CHANGE THE LAND USE DESIGNATION OF 21 PARCELS ON SAFFORD, BRODERICK, OAK AND LINCOLN STREETS TO MIXED USE AND THE ZONING TO DOWNTOWN MIXED-USE (APN's 012-021-008, -011, -012, -015, -018, -020, -021, -022, -023, -028, -029 AND APN's 012-028-003, -004, -005, -006, -007, -008, -009, -015, -016, AND APN 012-031-008).

**4. HOUSIGN ELEMENT UPDATE (2022-2030)**

The Planning Commission may conduct a public hearing to review the Draft 2022 General Plan Housing Element Update and make recommendations to the City Council regarding its adoption.

**RECOMMENDATION**

Conduct a public hearing regarding the Housing Element

Adopt Resolution No. P2022-08 - a resolution of intention recommending that the City Council:

Determine that the Housing Element is exempt from environmental review under CEQA, and

Adopt the Draft Element; and

Authorize submittal to the California Department of Housing and Community Development (HCD) for their certification.

**REPORTS / DISCUSSIONS / CORRESPONDENCE**

- 5. 1. Commissioner Reports
- 6. 2. Historical Advisory Commission Reports
- 7. 3. Staff Reports

## ADJOURN THE MEETING

The meeting will be adjourned. A regular meeting of the Oroville Planning Commission will be held on July 28, 2022 at 6:00 PM.

*Accommodating Those Individuals with Special Needs* – In compliance with the Americans with Disabilities Act, the City of Oroville encourages those with disabilities to participate fully in the public meeting process. If you have a special need in order to allow you to attend or participate in our public meetings, please contact the City Clerk at (530) 538-2535, well in advance of the regular meeting you wish to attend, so that we may make every reasonable effort to accommodate you. Documents distributed for public session items, less than 72 hours prior to meeting, are available for public inspection at City Hall, 1735 Montgomery Street, Oroville, California.

*Recordings* - All meetings are recorded and broadcast live on [cityoforoville.org](http://cityoforoville.org) and YouTube.

*Planning Commission Decisions* - Any person who is dissatisfied with the decisions of this Planning Commission may appeal to the City Council by filing with the Zoning Administrator within fifteen days from the date of the action. A written notice of appeal specifying the grounds and an appeal fee immediately payable to the City of Oroville must be submitted at the time of filing. The Oroville City Council may sustain, modify or overrule this decision.



Council Chambers  
1735 Montgomery Street  
Oroville, CA. 95965

**March 24, 2022  
REGULAR MEETING  
MINUTES**

---

This agenda was posted on March 18, 2022. This meeting was recorded and may be viewed at [cityoforoville.org](http://cityoforoville.org) or on YouTube.

---

**CALL TO ORDER / ROLL CALL**

- PRESENT: Commissioners: Glenn Arace, Natalie Sheard, Warren Jensen, Carl Durling
- ABSENT: Commissioners Marissa Hallen and Vice Chairperson Wyatt Jenkins
- STAFF: Assistant Community Development Director Dawn Nevers, Assistant City Clerk Jackie Glover, Assistant Planner Conner Musler, Principal Planner Wes Ervin, City Engineer Matt Thompson, City Clerk Intern Kaci Casaulong, Assistant Planner Danny Kopshever

**OPEN SESSION**

Pledge of Allegiance – Led by Chairperson Durling

**PUBLIC COMMUNICATION - HEARING OF NON-AGENDA ITEMS**

There were 0 public comments on non-agenda items.

Julie Miller spoke on agenda item 4.

**CONSENT CALENDAR**

Consent calendar items are adopted in one action by the Commission. Items that are removed will be discussed and voted on immediately after adoption of consent calendar items.

**1. APPROVAL OF THE MINUTES**

Motion by Commissioner Sheard and second by Commissioner Jensen to approve the minutes of February 24, 2022. Motion passed.

- AYES: Jensen, Arace, Sheard, Durling
- NOES: None
- ABSTAIN: None
- ABSENT: Hallen, Jenkins

**REGULAR BUSINESS**

**2. TENTATIVE PARCEL MAP WAIVER 2112-002**

The Oroville Planning Commission reviewed and considered approving a Parcel Map Waiver a lot split to facilitate the next phase of the Olive Ranch housing development along Table Mountain Boulevard at the end of Tuscan Villa Drive. The map will split one lot into two lots.

Motion by Commissioner Arace and Commissioner Jensen to approve the recommended Parcel Map Waiver subject to any conditions imposed by the City Engineer and adopt Resolution No. P2022-06. Motion passed.

- AYES: Jensen, Arace, Sheard, Durling
- NOES: None
- ABSTAIN: None
- ABSENT: Hallen, Jenkins

**3. CREATIVE SIGNS AT THE PACIFIC COAST PRODUCERS PLANT LOCATED AT 1601 MITCHELL AVENUE**

The Oroville Planning Commission reviewed and considered approving sign permit B2203-022 for the painting of two creative signs at the Pacific Coast Producers Plant at 1601 Mitchell Ave.

Motion by Commissioner Jensen and second by Commissioner Sheard to adopt the recommended Findings for Sign Permit No. B2203-022 and adopt Resolution No. P2022-05. Motion passed.

- AYES: Jensen, Arace, Sheard, Durling
- NOES: None
- ABSTAIN: None
- ABSENT: Hallen, Jenkins

**4. SANK PARK PERIMETER FENCE OPTIONS LOCATED AT 1067 MONTGOMERY STREET**

The Oroville Historic Advisory Commission reviewed and considered forwarding a recommendation of fencing to the City Council.

Motion by Commissioner Arace and second by Commissioner Sheard to recommend to council that the Sank Park fence will match the style of the home, a straight iron picket fence similar to the picture Commissioner Sheard recommended, dark matt gray, 5 ft, with inset entrances, no curb at the base, and gate stations.

- AYES: Jensen, Arace, Sheard, Durling
- NOES: None
- ABSTAIN: None
- ABSENT: Hallen, Jenkins

**5. HISTORIC PRESERVATION AWARD PROGRAM OF THE OROVILLE HISTORIC ADVISORY COMMISSION**

Item Continued to April 28, 2022

**REPORTS / DISCUSSIONS / CORRESPONDENCE**

- 6. Commissioner Reports - None
- 7. Historical Advisory Commission Reports - None
- 8. Staff Reports

- a. Ervin – April 5<sup>th</sup> Council Meeting– Massage Ordinance, Contract with Place Works, Bingo Ordinance, April 19<sup>th</sup> Council Meeting – Fence Ordinance, April 28<sup>th</sup> – Historic Advisory Award, Second Meeting of the South Oroville Advisory Group will be March 31<sup>st</sup>.

Item 1.

## **ADJOURN THE MEETING**

Chairperson Durling Adjourned the meeting at 7:16pm.

APPROVED:

ATTESTED:

\_\_\_\_\_  
Chairperson Carl Durling

\_\_\_\_\_  
Assistant City Clerk Jackie Glover



**May 26, 2022  
MINUTES**

---

This agenda was posted on Friday, May 20, 2022. This meeting was recorded and may be viewed at [cityoforoville.org](http://cityoforoville.org)

---

## **CALL TO ORDER / ROLL CALL**

Chairperson Durling opened the meeting at 6pm

**PRESENT:** Commissioners: Glenn Arace, Natalie Sheard, Warren Jensen, Vice Chairperson Wyatt Jenkins, Chairperson Carl Durling

**ABSENT:** Commissioner Marissa Hallen

**STAFF:** Senior Planner Wes Ervin, Assistant Planner Danny Kopshever, Assistant Planner Conner Musler, Assistant City Clerk Jackie Glover

## **OPEN SESSION**

Pledge of Allegiance – Led by Chairperson Durling

## **PUBLIC COMMUNICATION - HEARING OF NON-AGENDA ITEMS**

There were 0 public comments at this meeting.

## **CONSENT CALENDAR**

Motion by Commissioner Sheard and second by Vice Chairperson Jenkins to approve the consent calendar. Motion passed.

### **1. APPROVAL OF THE MINUTES**

The Commission approved the minutes of April 28, 2022

## **REGULAR BUSINESS**

### **2. MCGREEN ESTATES TENTATIVE SUBDIVISION MAP 19-02 EXTENSION**

The Planning Commission considered a two-year extension of Tentative Subdivision Map No. 19-02, which would separate a 1.89-acre lot into 15 parcels for medium density residential housing.

**Motion by Vice Chair Jenkins and second by Commissioner Jensen to APPROVE** a two-year extension for Tentative Parcel Map No. 19-02; and **APPROVE** Resolution No. P2022-07 A RESOLUTION OF THE OROVILLE CITY PLANNING COMMISSION APPROVING THE EXTENSION OF A TENTATIVE PARCEL MAP FOR THE MCGREEN ESTATES SUBDIVISION (APN 031-150- 031). Motion passed.

### 3. FORMER OROVILLE FORD DEALERSHIP INTERIOR AND EXTERIOR IMPROVEMENTS

Item 1.

The Historic Advisory Commission reviewed proposed façade improvements to 1726 & 1790 Montgomery Street, and at Oak & Safford, all at the former Ford Dealership (APN's 012-028-010, -014, and -016). This is the first piece of a larger renovation project on the block. The other parts of the project will be reviewed as applicant finishes planning and files appropriate applications.

#### RECOMMENDATION

Motion by Commissioner Sheard and second by Commissioner Jensen to approve the proposed façade changes. Motion passed.

## REPORTS / DISCUSSIONS / CORRESPONDENCE

- 4. Commissioner Reports - None
- 5. Historical Advisory Commission Reports - None
- 6. Staff Reports
  - Kopshever – Provided next step options for the Historical Advisory Award.
  - Ervin – Provided an update on what is upcoming for DRC and Planning Commission, gave an update regarding the fence ordinance at council, and other Planning Department Updates.

## ADJOURN THE MEETING

Meeting Adjourned at 7:01pm by Chairperson Durling

APPROVED:

ATTESTED:

\_\_\_\_\_  
Chairperson Carl Durling

\_\_\_\_\_  
Assistant City Clerk Jackie Glover



# City of Oroville

**Dawn Nevers**  
Assistant Director

## COMMUNITY DEVELOPMENT DEPARTMENT

1735 Montgomery Street  
Oroville, CA 95965-4897  
(530) 538-2436 FAX (530) 538-2426  
[www.cityoforoville.org](http://www.cityoforoville.org)

### PLANNING COMMISSION STAFF REPORT

Thursday, June 23, 2022

**RE: Ozone Entertainment – Use Permit #22-02 for 1726 Montgomery Street**

**SUMMARY:** Minor Use Permit UP#22-02 for Ozone Entertainment, a new indoor recreational facility, including hatchet throwing, alcohol sales, and Segway and bicycle rentals.

**RECOMMENDATION: Staff recommends the following actions:**

1. **Recommend Adoption of the Notice of Exemption** as the appropriate level of environmental review in accordance with the California Environmental Quality Act (CEQA);
2. **Adopt** Use Permit #UP 22-03 including the recommended Findings and permit conditions, and
3. **Adopt** Resolution No. P2022-09: A RESOLUTION OF THE OROVILLE PLANNING COMMISSION MAKING FINDINGS AND CONDITIONALLY APPROVING MINOR USE PERMIT UP22-03 FOR OZONE ENTERTAINMENT, AN INDOOR COMMERCIAL RECREATIONAL FACILITY AT 1726 MONTGOMERY STREET (APN 012-028-013 & -015)

**APPLICANTS:** Ozone Entertainment, LLC

**LOCATION:** 1726 Montgomery Street, Oroville, California (APN 012-028-013 & -015)

**GENERAL PLAN:** PARK (Parks and Recreation)  
**ZONING:** PQ (Public Quasi-Public)  
**FLOOD ZONE:** Zone X

**ENVIRONMENTAL DETERMINATION:** Categorically Exempt as an Existing Facility per Section 15301 of Title 14, California Code of Regulations.

**REPORT PREPARED BY:**

\_\_\_\_\_  
Daniel Kopshever, Assistant Planner  
Community Development Department

**REVIEWED BY:**

\_\_\_\_\_  
Dawn Nevers, Assistant Director  
Community Development Director

## DISCUSSION

Ozone Entertainment is a proposed indoor entertainment facility, with hatchet throwing as its main attraction. The venue will be offering Segway and bicycle rentals, prepackaged food and alcoholic beverages (no hard alcohol), and other indoor entertainment.

The building is on the corner of Safford and Oak streets, adjacent to and behind the Ford dealership on Montgomery Street. Interior tenant improvements have commenced, but final occupancy cannot be approved until this Use Permit is granted by the Planning Commission. No exterior façade changes or signage has been proposed as part of this Use Permit, but the façade improvements planned for the Ford dealership will include the Ozone Entertainment building in a later phase.

The current zoning of this property is Public, Quasi-Public (PQ) which does not permit the use classification of indoor recreational facility. The city has initiated a zoning change to Downtown Mixed-Use (MXD) for this and some of the surrounding PQ zoned parcels. MXD does not allow indoor recreational facilities either. However, the project does fall within the Arts, culture, and Entertainment Overlay District (ACE-O) and the Downtown Historic District. The ACE Overlay aims to revitalize the historic downtown area as a recreational, community, and tourist destination. As-of-right uses in the ACE-O district explicitly include dance, painting, gymnastics, martial arts, yoga, and “other related arts or similar activities.” The proposed commercial use by applicant Ozone Entertainment is a family friendly activity center which exemplifies the ACE-O goals regarding community, recreation and tourism. The proposed use would not involve a higher level of activity, density or intensity than other allowable uses in the PQ and MXD districts.

Ozone Entertainment aims to provide a place for community members to have fun in a safe, clean and drug free environment for kids, teens and adults. Extreme heat in the summer often prevents visitors and community members from comfortably enjoying the outdoor public spaces of Oroville. An indoor space for people of all ages to recreate does not currently exist in the downtown area.

Applicants have submitted site plans and safety handbooks/protocols for the Axe throwing and the Segway rentals.

Signage has not been submitted, would be approved under a separate administrative permit.

Alcohol License application has not been submitted. Applicant is requesting approval to prepare a Letter of Public Convenience or Necessity for when they submit to California Alcohol and Beverage Control for beer and wine sales.

Food would be prepackaged and shall not require cooking of any kind.

## FISCAL IMPACT

None. The project is subject to all customary fees.

## PUBLIC NOTICE

A request for comments was prepared and circulated to the local agencies and surrounding property owners within 300 feet of the property. Additionally, the meeting date, time, and project description were published in the Oroville Mercury Register and posted at City Hall.

**ATTACHMENTS**

1. Application materials
2. Resolution P2022-09
3. Notice of Exemption (CEQA)
4. Draft letter of approval with proposed conditions



# City of Oroville

Planning Division - Community Development Department

1735 Montgomery Street  
 Oroville, CA 95965-4897  
 (530) 538-2430 FAX (530)  
 538-2426 [www.cityoforoville.org](http://www.cityoforoville.org)

Item 2.

TRAKIT#: PL2205-002

## USE PERMIT APPLICATION

(Please print clearly and fill in/provide all that apply)

REQUIRED FOR A COMPLETE APPLICATION		PERMIT TYPE	
<input type="checkbox"/>	Completed and signed Application Forms	<input checked="" type="checkbox"/>	New Use Permit: \$2,889.98 (Deposit) + \$173.40(6% Tech Fee) = \$3,063.38
<input type="checkbox"/>	Application Fee Paid	<input type="checkbox"/>	Amendment to Existing Use Permit: \$1,024.09 + \$61.45 (6% Tech Fee) = \$1,085.54

### PROJECT PLANS

All plans and drawings shall be drawn to scale to the extent feasible and shall indicate the full dimensions, contours and other topographic features and all information necessary to make a full evaluation of the project. Please include the following:

1. **Site and floor plans**, including the location, square footage and use of all structures.
2. **Architectural drawings** showing proposed building elevations.
3. Landscape plans showing the types, sizes and location of vegetation to be planted and the irrigation system to be installed
4. Plans for the configuration & layout of all off-street parking spaces, including entrances, exits and internal circulation routes.
5. Plans for all lighting to be installed on the site, including the location, type, height and brightness of each lighting fixture.
6. **Drawings of all signs** that are proposed in association with the project.
7. Plans showing the location, sq footage and capacity of any existing or proposed surface storm-water detention facilities.
8. Plans showing the location and square footage of any existing or proposed outdoor storage areas.
9. Descriptions of any off-site infrastructure improvements to be provided in conjunction with the project.
10. Hours of operation for all proposed land uses. **MON-SUN 10AM-11PM**
11. Number of employees and fleet vehicles for all proposed land uses **2 ~~2~~ No Vehicles**
12. **A letter authorizing the use permit application from the owner of the property.**

### CLASSIFICATION

<input checked="" type="checkbox"/>	Alcohol & Beverage Sales	Nonconforming Uses & Structures	Uses in Industrial Districts
	Agricultural Uses	Outdoor Storage	Uses Mini-Storage Overlay(MS-O)
	Animal Keeping (Commercial)	Parking Requirement Exceptions	Uses in Residential Districts
	Barbed/Razor Wire Fence	Temporary Use	Uses in Special Purpose Districts
	Density Bonus & Other Incentives	Uses in a Conditional Overlay (C-O)	Uses not Specified but Allowed
	Exceptions to Height Limits	Uses in Commercial & Mixed-Use Districts	Wireless Communication Facilities

Other: (Please Specify) **Commercial Recreational Facility ≤ 10 KSF**

### APPLICANT'S SIGNATURE

I hereby certify that the information provided in this application is, to my knowledge, true and correct.

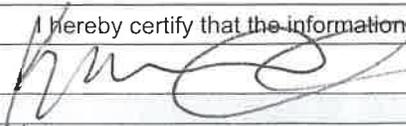
Signature:  Date: **5.6.22**

### OFFICE USE ONLY

Approved By: \_\_\_\_\_ Date: \_\_\_\_\_  
 Payment: \_\_\_\_\_ Number: \_\_\_\_\_

PROJECT DESCRIPTION	
Present or Previous Use:	Ford Dealership PARTS DEPT
Proposed Use:	FAMILY Entertainment.
Detailed Description:  AXE THROWS, RENTALS, Entertainment GAMES, PRIVATE kids PARTYS etc. Bikes, segways, PARTS.	

The Community Development Department operates on a full cost recovery for processing of permits. Staff will charge their time and any expenses associated with processing the application against the initial deposit. Fees that have been captured for the reimbursement of City expenses are non-refundable.

Technology cost recovery fees are non-refundable



# City of Oroville

Planning Division - Community Development Department

1735 Montgomery Street  
 Oroville, CA 95965-4897  
 (530) 538-2430 FAX (530) 538-2426  
[www.cityoforoville.org](http://www.cityoforoville.org)

Item 2.

TRAKIT#: PL2205-002

## PLANNING DIVISION GENERAL APPLICATION

(Please print clearly and fill in all that apply)

<b>APPLICANT'S INFORMATION</b>		Project's:	
Name:	O'zone Entertainment LLC	Name:	
Address:	1726 Montgomery St suit 3	Company:	
Phone:	530 990 6233	Address:	
Email:	ozoneoroville@gmail.com	Phone:	
Is the applicant the Owner?	<input type="checkbox"/>	If applicant is <u>Not</u> the owner, please provide owner /agent authorization on the reverse side.	Email:

### DEVELOPMENT PROJECTS & OTHER APPLICATIONS (Please check all that apply)

<input type="checkbox"/>	Annexation	<input type="checkbox"/>	Landmark /Modification/Demolition	<input type="checkbox"/>	Tentative Parcel Map
<input type="checkbox"/>	Appeal	<input type="checkbox"/>	Mining and Reclamation Plan	<input type="checkbox"/>	Tentative Subdivision Map
<input type="checkbox"/>	Development Review	<input type="checkbox"/>	Pre-Application	<input type="checkbox"/>	Use Permit
<input type="checkbox"/>	Final Map	<input type="checkbox"/>	Residential Density Bonus	<input type="checkbox"/>	Variance
<input type="checkbox"/>	General Plan Amendment/Rezone	<input type="checkbox"/>	Temporary Use	<input type="checkbox"/>	Wireless Communication Facilities
<input type="checkbox"/>	Landmark Designation	<input type="checkbox"/>	Tentative Map Extension	<input type="checkbox"/>	Zoning Clearance
<input type="checkbox"/>	Other: (Please Specify)				

### ADMINISTRATIVE PERMITS (Please check all that apply)

<input type="checkbox"/>	Adult Oriented Business	<input type="checkbox"/>	Outdoor Storage	<input type="checkbox"/>	Special Event
<input type="checkbox"/>	Home Occupation	<input type="checkbox"/>	Outdoor Display & Sales	<input type="checkbox"/>	Street Closure
<input type="checkbox"/>	Large Family Day Care	<input type="checkbox"/>	Second Dwelling Unit	<input type="checkbox"/>	Tree Removal
<input type="checkbox"/>	Mobile Food Vendor	<input type="checkbox"/>	Sign/Temporary Sign Permit	<input type="checkbox"/>	
<input type="checkbox"/>	Other: (Please Specify)				

\*Please provide a letter addressed to the Planning Division with a detailed description for the proposed project. Please include any site plans, maps, aerials, photos, and other relevant information that will help us in processing your application.

\*\* Any time a set of plans is required, three (3) sets of drawings shall be submitted, unless otherwise directed.

### PROJECT INFORMATION

Project Name:	O'zone Entertainment LLC	Proposed Structure(s) (Sq Ft.):	
Address:	1726 Montgomery St suit 3	Existing Structure(s) (Sq Ft.):	
Nearest Cross Street:	Oak/Montgomery	Water Provider:	
Assessor Parcel Number:		School District:	
Lot Size (Acres):		Number of Dwelling Units:	

### APPLICANT'S SIGNATURE

I hereby certify that the information provided in this application is, to my knowledge, true and correct.

Signature:		Date:	5.6.22
------------	--	-------	--------

### OFFICE USE ONLY

General Plan:		Zoning:		Zoning Conformity:		APN:	
File#		Overlay Zoning:		Minimum Setbacks:	FY	RY	SY

<b>AGENT AUTHORIZATION</b>			
To the City of Oroville, Department of Community Development			
NAME OF AGENT:		PHONE NUMBER:	
COMPANY NAME:		EMAIL:	
ADDRESS:		CITY/ST/ZIP:	
AGENT SIGNATURE:			
Is hereby authorized to process this application on my/our property, identified as Butte County Assessor Parcel Number (s):			
This authorization allows representation for all applications, hearings, appeals, etc. and to sign all documents necessary for said processing, but not including document (s) relating to record title interest.			

**Owner(s) of Record (sign and print name)**

1)	_____	_____	_____
	Print Name of Owner	Signature of Owner	Date
2)	_____	_____	_____
	Print Name of Owner	Signature of Owner	Date
3)	_____	_____	_____
	Print Name of Owner	Signature of Owner	Date
4)	_____	_____	_____
	Print Name of Owner	Signature of Owner	Date
	_____	_____	_____
	Owner's Mailing Address	Owner's Email	Owner's Phone #

The Community Development Department operates on a full cost recovery for processing of permits. Staff will charge their time and any expenses associated with processing the application against the initial deposit. Fees that have been captured for the reimbursement of City expenses are non-refundable.

Technology cost recovery fees are non-refundable



# City of Oroville

Building Department  
Cash Collections  
**RECEIPT: P1160**

**Project Number: PL2205-002**  
**Project Name: Commercial Rec Facility & Alcohol and beverage sales**

Fee Description	Account Number	Fee Amount
TECH COST RECOVERY [SU		
	5141 4700	\$173.40
USE PERMIT FEES		
	2201 4260	\$2,889.98
<b>Total Fees Paid:</b>		<b>3,063.38</b>

Date Paid: 5/9/2022

Paid By: O'Zone Entertainment LLC

Pay Method: CHECK

Check # 1004

Received By: CECILIA CARMONA

\*\*\*Credit Card Payments\*\*\*

A convenience fee is charged for all credit card payments. Please note that the convenience fee is a third-party fee and is not part of the City of Oroville. For all credit card payments the convenience fee is 2.50% of the total amount charged with a minimum charge of \$2.00.

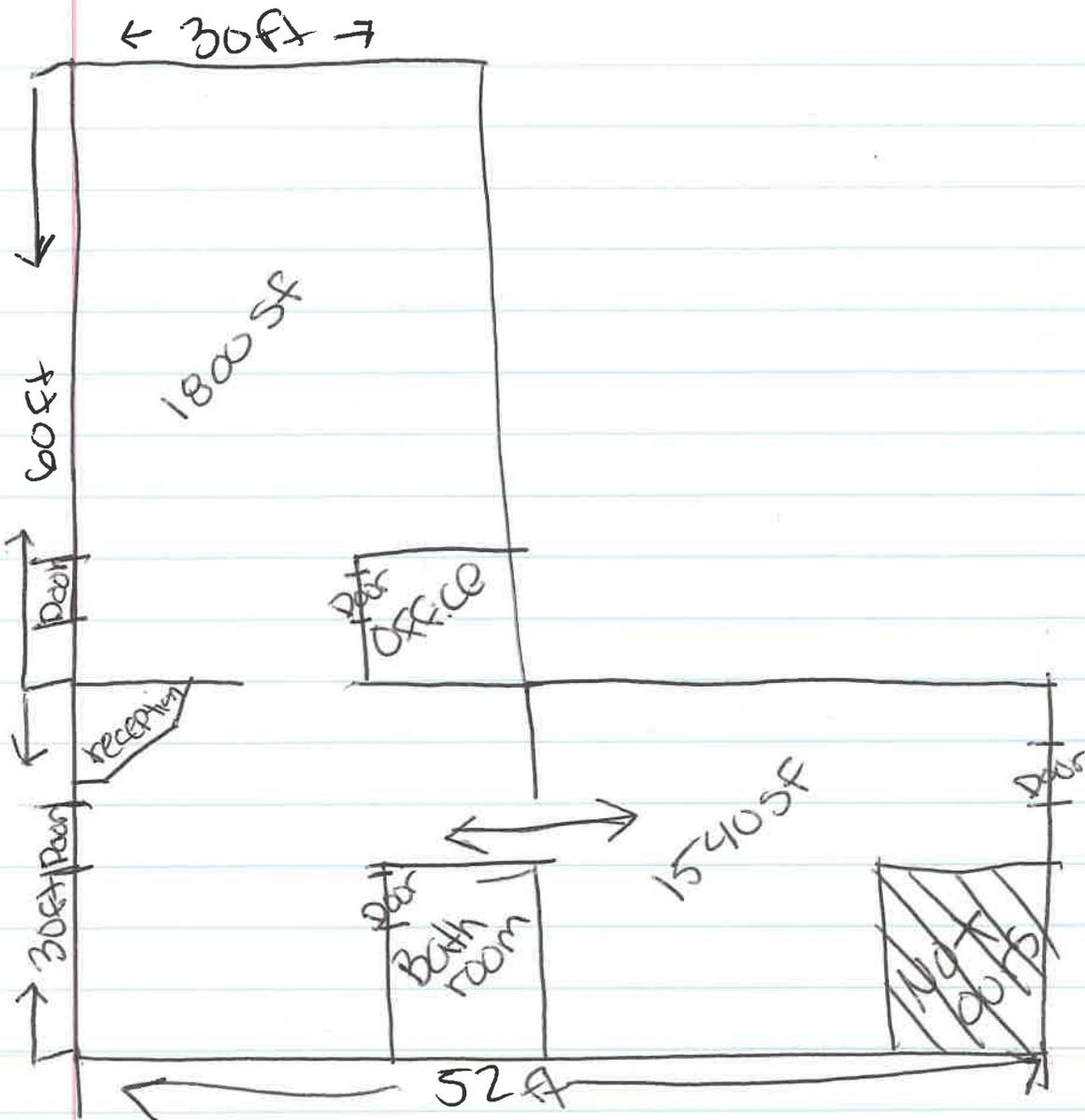

public Area 3,300 SF



# City of Oroville

COMMUNITY DEVELOPMENT DEPARTMENT

1735 Montgomery Street  
Oroville, CA 95965-4897  
(530) 538-2401 – FAX (530) 538-2426  
[www.cityoforoville.org](http://www.cityoforoville.org)

## ZONING CLEARANCE/OCCUPANCY PERMIT APPLICATION

Date Submitted

03/07/22

Trakit Number

B2203-021

1726 Montgomery Street

New Business Address

suites 3,4

Old Business Address

INDICATE PROPOSED USE/USES:

Family Entertainment, education,  
special needs groups

### Office Use Only

Zoning Clearance  
(For Planning Department Use Only)

Proposed Use  
(check all that apply)

Finance Dept.  
Verify SC-OR Code

APN: 012 - 028 - 014

Property Zoning: <sup>DQ</sup> MXD

Use allowed by zoning?  Yes  No If not allowed at all, is use nonconforming?  Yes  No

Is Use Permit required?  Yes  No Has Use Permit been obtained?  Yes (permit #\_\_\_\_)  No

If permit has been obtained, is new use substantially different from use for which permit was issued (expanded in intensity, longer hours, etc.)?

If yes, modified Use Permit may be required.

Does site conform to current development standards?  Yes  No

Parking lot shade?  Yes  No other landscaping?  Yes  No

If no, site improvements may be required (City staff will review response if building/lease space has been vacant more than one year & if building/lease space is not part of larger complex of similar uses.) Comments (Note: All comments are typed on the Certificate of Occupancy.):

Signature of Planner

Date

# ZONING CLEARANCE/OCCUPANCY PERMIT APPLICATION

Item 2.

This application is NOT a Certificate of Occupancy. The building for which this application is submitted shall NOT be occupied until such time as the necessary inspections have been made and all corrections accomplished, and the Certificate of Occupancy approved by the appropriate departments. At that time a City business license will be issued. Any variance from these requirements shall be authorized only by the City of Oroville, Building Department. Violation of occupancy requirements (Oroville City Code Section 6-1.1) constitutes an infraction and may result in legal action. To avoid delays in processing this application, please complete it in its entirety. Return the completed application to the Building Department at 1735 Montgomery Street, Oroville, CA 95965-4897, so that an inspection date and time can be conveniently scheduled.

**Business Name:** O'Zone Entertainment LLC

**Type of Business:** Family Entertainment/Education

Site Address of Business & Suite No.		Business Phone No.
1726 Montgomery St Suite 3+4		
Business Owner #1	Home Address (Owner #1)	Home or Cell Phone No.
Kaitlin medeiros	4159 Oro Bingham Oroville 95966	530 353 1653
Business Owner #2	Home Address (Owner #2)	Home or Cell Phone No.
Sylvia Sweet	2 Northview Dr Oroville CA 95966	530 370 0440
Applicant's Name	Home Applicant's Address	Home or Cell Phone No.
Ozone Entertainment		

Will there be any remodeling done? If so, please explain in detail – permits may be required.

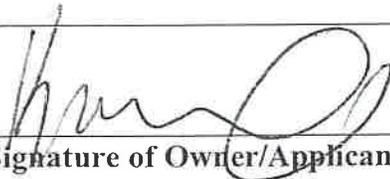
  
 \_\_\_\_\_  
 Signature of Owner/Applicant

3-7-22  
 \_\_\_\_\_  
 Date

**For Office Use Only:**

Business License Occupancy Fee: \$146.55

Credit Card Payment:     VISA                       Cash  
 Expiration Date \_\_\_\_\_  MC                       Check # \_\_\_\_\_

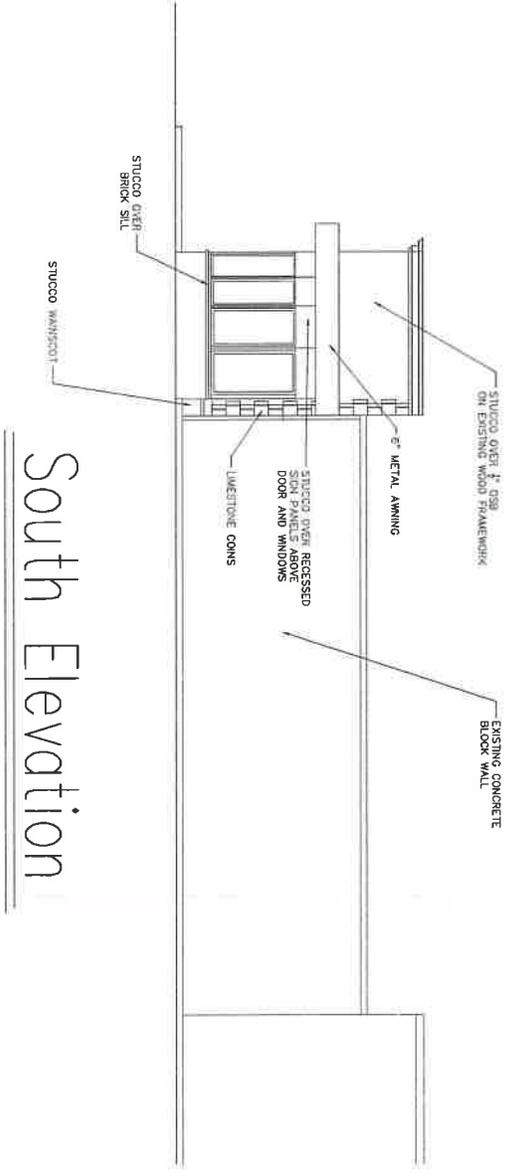

South Elevation

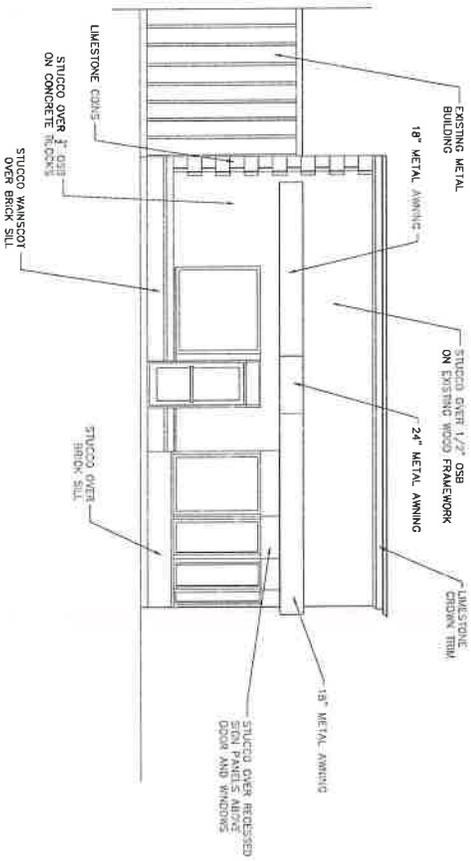

West Elevation

JOE THUNDER  
OROVILLE, FLO  
SHEET NO.  
A2

ELEVATION  
RENOVATION

drawn by  
DGA  
checked  
date  
5/18/2022

David G. Anderson, Architect  
41 Butte Woods Drive, Oroville, California 95966  
Phone (530) 693-4546, Cell (530) 520-0211, E-mail dgarchitect@sbcglobal.net



# CONTACTS

OWNER/BUILDER:

MARK MENDEZ  
2585 ORO DAM LLC  
P.O. BOX 5686, OROVILLE, CA 95966  
(409) 396-9442

ARCHITECT:

DAVID G. ANDERSON, ARCHITECT  
41 BUTTE WOODS DRIVE  
OROVILLE, CALIFORNIA 95966  
(530) 693-4546 CA LICENSE#23903

# CODE ANALYSIS

BUILDING ADDRESS:

SUITE TWO, 1740 MONTGOMERY STREET, OROVILLE, CA 95966

ASSESSOR'S PARCEL NUMBER 012-028-016

2019 CALIFORNIA RESIDENTIAL CODE, 2019 CA FIRE CODE, 2019 CA MECHANICAL CODE, 2019 CA PLUMBING CODE, 2019 CA ENERGY CODE, 2019 CA GREEN BUILDING CODE

ZONING:

SCORE OF WORK: RENOVATE AN EXISTING BUILDING IN THE OROVILLE FOOD DEALERSHIP PROPERTY FOR USE AS A BUSINESS PROVIDING RENTALS FOR LOCAL USE, AND ON SITE GAMES

BUILDING TYPE:

TYP. WB - WOOD FRAME CONSTRUCTION

OCCUPANCY TYPE:

B - BUSINESS

STRUCTURAL LOADS:

FLOOR LOADS - LIVE LOAD = 40 PSF, SLEEPING ROOM LIVE LOAD = 30 PSF, DEAD LOAD = 10 PSF  
ROOF LOADS - LIVE LOAD = 20 PSF, DEAD LOAD = 15 PSF, GROUND SNOW LOAD = 37 PSF  
MINIMUM SOIL BEARING CAPACITY = 1,500 POUNDS PER SQUARE FOOT, BASIC WIND SPEED = 110 MPH  
EARTHQUAKE SPECTRAL ACCELERATION FOR SHORT PERIODS  $S_s = 0.554$ , SEISMIC DESIGN CATEGORY = D<sub>2</sub>

AREA OF BUILDING:

TENANT AREA = 3,290 SF

UTILITIES:

PUBLIC SEWER, PUBLIC WATER SYSTEM, PGE GAS AND ELECTRIC

PARCEL AREA:

0.10 AC

JURISDICTION:

CITY OF OROVILLE, CALIFORNIA

ELEVATION:

APPROXIMATELY 162 FEET ABOVE SEA LEVEL, 0.75% GROUND SLOPE LOAD

WIND LOAD:

110 MPH 3-SECOND GUST

FIRE SPRINKLERS:

EXISTING BUILDING

WILDFIRE URBAN INTERFACE:

PROJECT IS NOT LOCATED IN THE WILDFIRE URBAN INTERFACE AREA

# DRAWING INDEX

C1 COVER SHEET

A1 SITE PLAN

A2 FLOOR PLAN

A3 DETAILS

A4 EXTERIOR ELEVATIONS

A5 REFLECTED CEILING PLAN

A6 NOTES AND SCHEDULES

# HERS INSPECTIONS

DEFERRED

# SYMBOLS AND ABBREVIATIONS

A	ASBESTOS	B	BARRIER	C	CANOPY	D	DECK	E	ELECTRICAL	F	FLOORING	G	GLASS	H	HATCH	I	INSULATION	J	JUNCTION	K	KITCHEN	L	LANDSCAPE	M	MATERIAL	N	NOTES	O	OPENING	P	PLUMBING	Q	QUALITY CONTROL	R	REPAIR	S	SEWER	T	TERRAZZO	U	UTILITY	V	VENTILATION	W	WALL	X	WOOD	Y	YARD	Z	ZONING
---	----------	---	---------	---	--------	---	------	---	------------	---	----------	---	-------	---	-------	---	------------	---	----------	---	---------	---	-----------	---	----------	---	-------	---	---------	---	----------	---	-----------------	---	--------	---	-------	---	----------	---	---------	---	-------------	---	------	---	------	---	------	---	--------

# PROXIMITY MAP

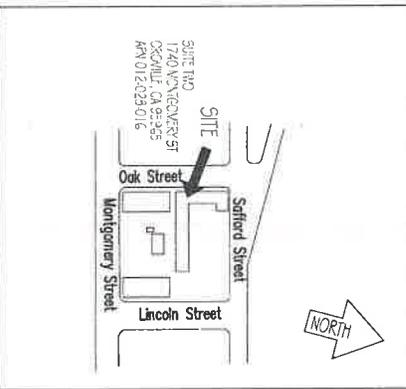

<p>DATE: 6/7/2022</p> <p>drawn by: DGA</p> <p>checked: [Signature]</p>	<p>David G. Anderson, Architect</p> <p>41 Butte Woods Drive, Oroville, CA 95966</p> <p>Phone (530) 693-4546 Cell (530) 520-0211 E-mail dgaarchitect@sbcglobal.net</p>		<p>DATE: 6/7/2022</p> <p>DESIGNER: Mark Mendez</p> <p>PROJECT: COMMERCIAL RENOVATION PROJECT FOR OROVILLE, SUITE 2</p> <p>SHEET NO: C1</p>
--	---	--	--

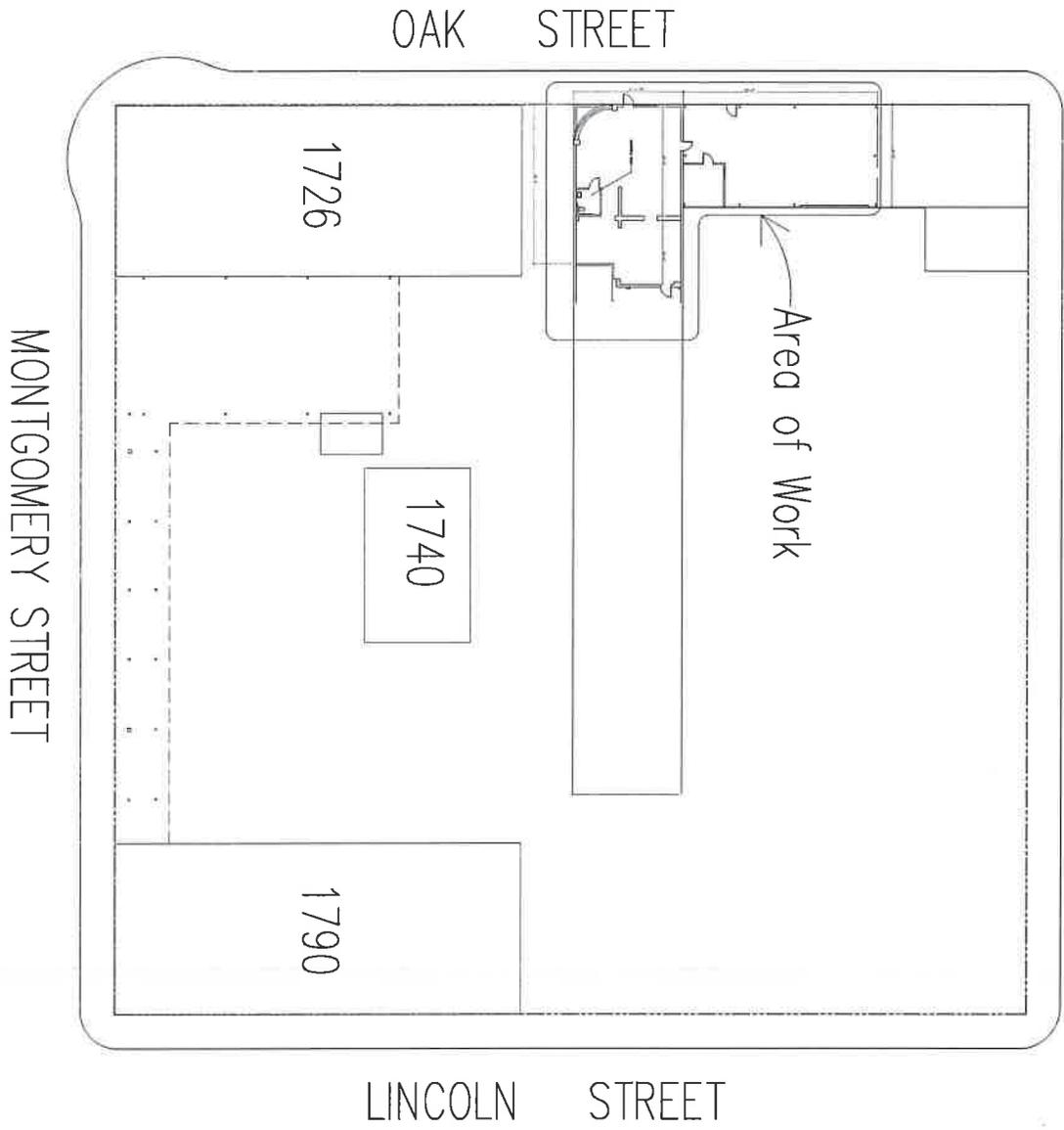

AS-BUILT FLOOR PLANS  
 SCALE = 1/8" = 1'-0"  
 OLD OROVILLE FORD DEALERSHIP  
 1726 MONTGOMERY STREET, OROVILLE, CA

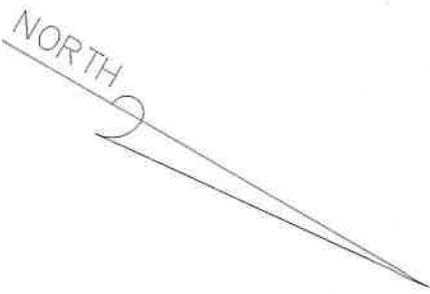

JOB NUMBER OZONE, SHEET 2 SHEET NO. <b>A1</b>	<h2 style="text-align: center;">Existing Site Plan</h2>	drawn by DGA checked  date 6/1/2022	<h3 style="text-align: center;">David G. Anderson, Architect</h3> <p style="text-align: center;">41 Butte Woods Drive, Oroville, California 95966          Phone (530) 693-4546 Cell (530) 520-0211. E-mail dgaarchitect@sbcglobal.net</p>	
--	---	--	--	--

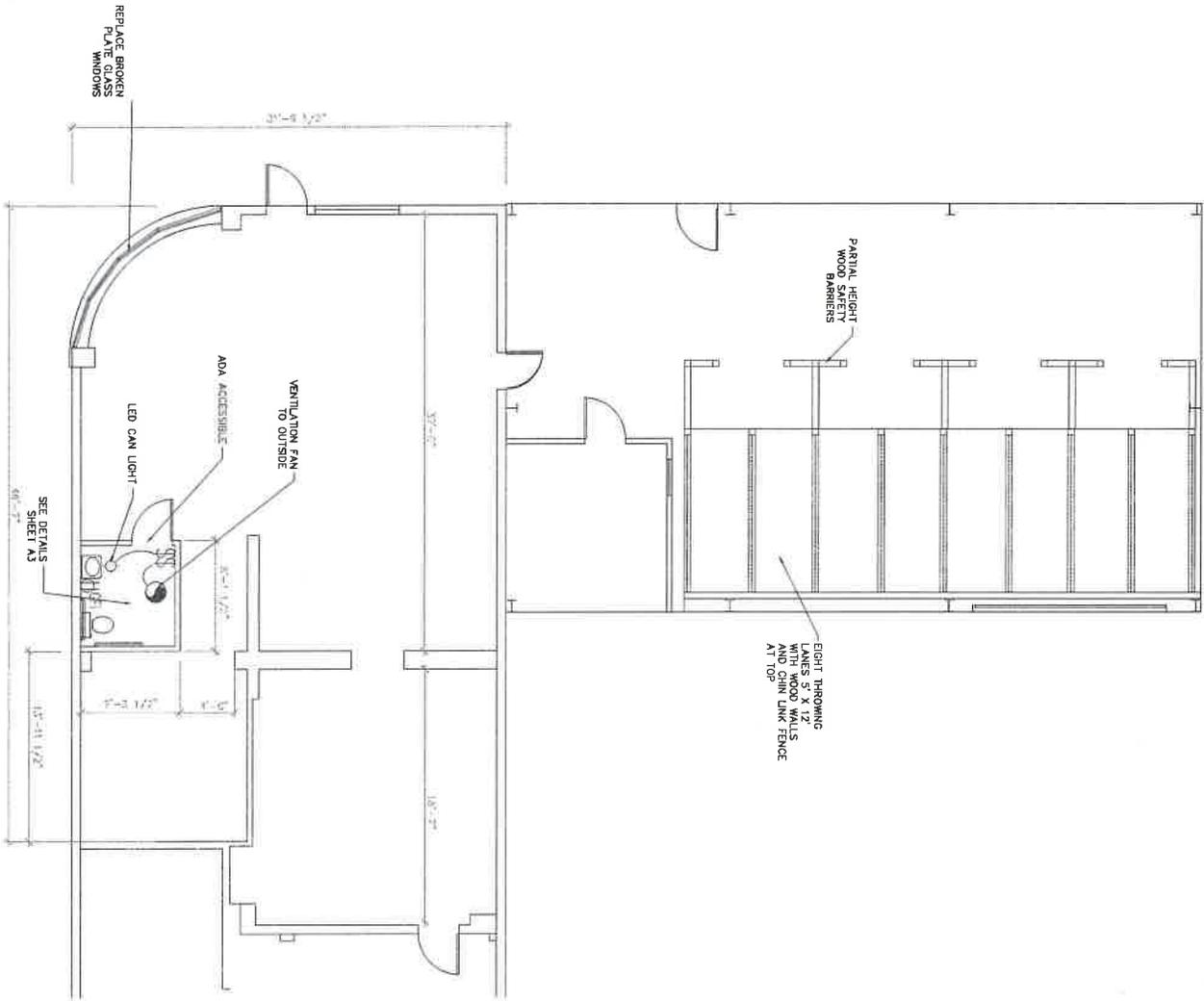

# IMPROVEMENT FLOOR PLAN

SCALE = 1/4" = 1'-0"  
 OLD OROVILLE FORD DEALERSHIP  
 1726 MONTGOMERY STREET, SUITE 2, OROVILLE, CA  
 TOTAL TENANT AREA = 3,290 SF  
 OCCUPANCY TYPE - B - BUSINESS  
 NUMBER OF OCCUPANTS = 3290/150 = 22  
 REQUIRED EXISTS = <50 = 1, 2 PROVIDED  
 # OCCUPANTS PER CPC = 3290/200 = 17  
 REQUIRED TOILETS = 1 MIXED USE OK  
 LONGEST PATH OF TRAVEL TO EXIT = 59'

SCHEDULE OF SYMBOLS	
	EXISTING FULL HEIGHT WALL
	PARTIAL HEIGHT WALL
	NEW FULL HEIGHT WALL
	WINDOW
	NEW OR EXISTING HINGED DOOR
	SLIDING HARDWARE DOOR
	NEW DOOR NUMBER - SEE SCHEDULE
	NEW WINDOW NUMBER - SEE SCHEDULE
	SECTION OR DETAIL / SHEET LOCATION
	ELEVATION - SHEET LOCATION
	KITCHEN SINK
	BATH SINK IN COUNTER
	WALL HUNG LAVATORY SINK
	JANITOR FLOOR SINK
	ADA ACCESSIBLE TOILET WHI REQUIRED HAND RAILS

JOB NUMBER OZONE, SUITE 2 SHEET NO <b>A2</b>	As-Built Floor Plans	drawn by DGA checked	David G. Anderson, Architect 41 Butte Woods Drive, Oroville, California 95966 Phone: (530) 693-4546, Cell: (530) 520-0211, E-mail: dgaarchitect@sbcglobal.net	
		date 6/7/2022		

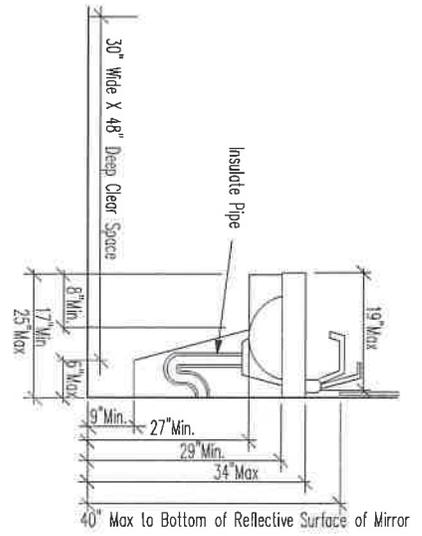

A.D.A. Lavatory Elevations 3  
A3

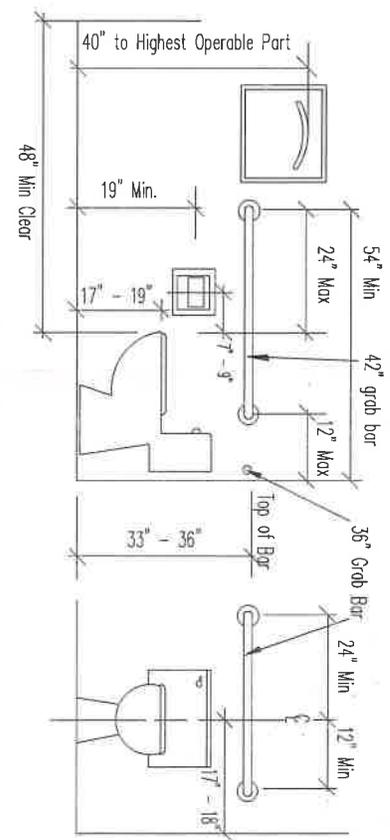

A.D.A. Toilet Elevations 2  
A3

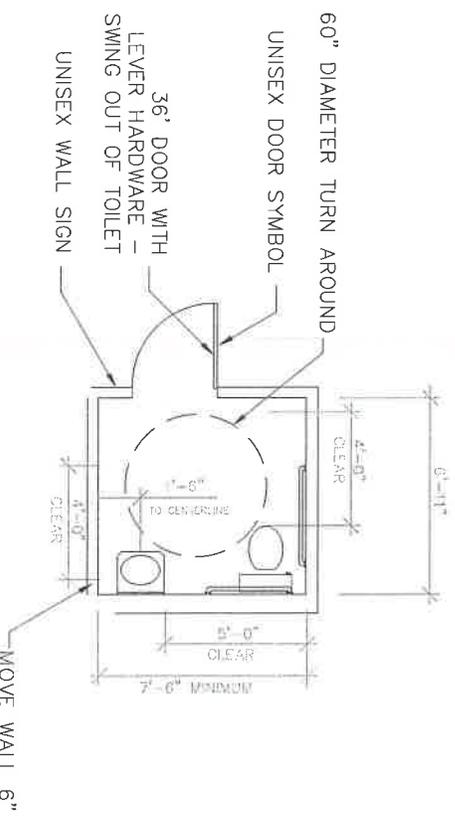
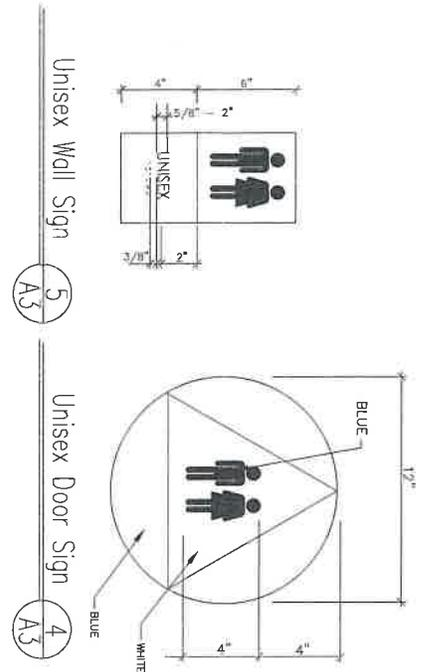

A.D.A. Single Use Toilet 1  
A3

- NOTES
1. TOILET ROOM WALL SIGN TO HAVE CONTRACTED GRADE 2 BRAILLE CENTERED 3/8" BELOW TEXT. DOTS IN EACH CELL TO BE 1/10" APART AND CELLS TO BE 2/10" APART. DOTS TO BE DOWED OR ROUNDED.
  2. TOILET ROOM WALL SIGN TO BE MOUNTED AT 48" TO 60" ABOVE FINISHED FLOOR TO THE TOILET OR RAISED CHARACTERS ON THE LATCH SIDE OF THE DOOR OR ROUTE OF EXIT.
  3. TOILET DOOR SIGN TO BE MOUNTED IN THE CENTER OF THE DOOR AT 48" TO 60" ABOVE THE FLOOR TO THE RAISED CHARACTERS.

<p>JOB NUMBER <b>020ME_SUIE 2</b></p> <p>SHEET NO <b>A3</b></p>	<p>Accessible Toilets Detail Plans</p>	<p>drawn by DGA</p> <p>checked</p> <p>date 6/7/2022</p>	<p><b>David G. Anderson, Architect</b></p> <p>41 Butte Woods Drive, Oroville, CA 95966</p> <p>Phone (530) 693-4546. Cell (530) 520-0211. E-mail dgaarchitect*bcglobal.net</p>	
---	--	---	---	--

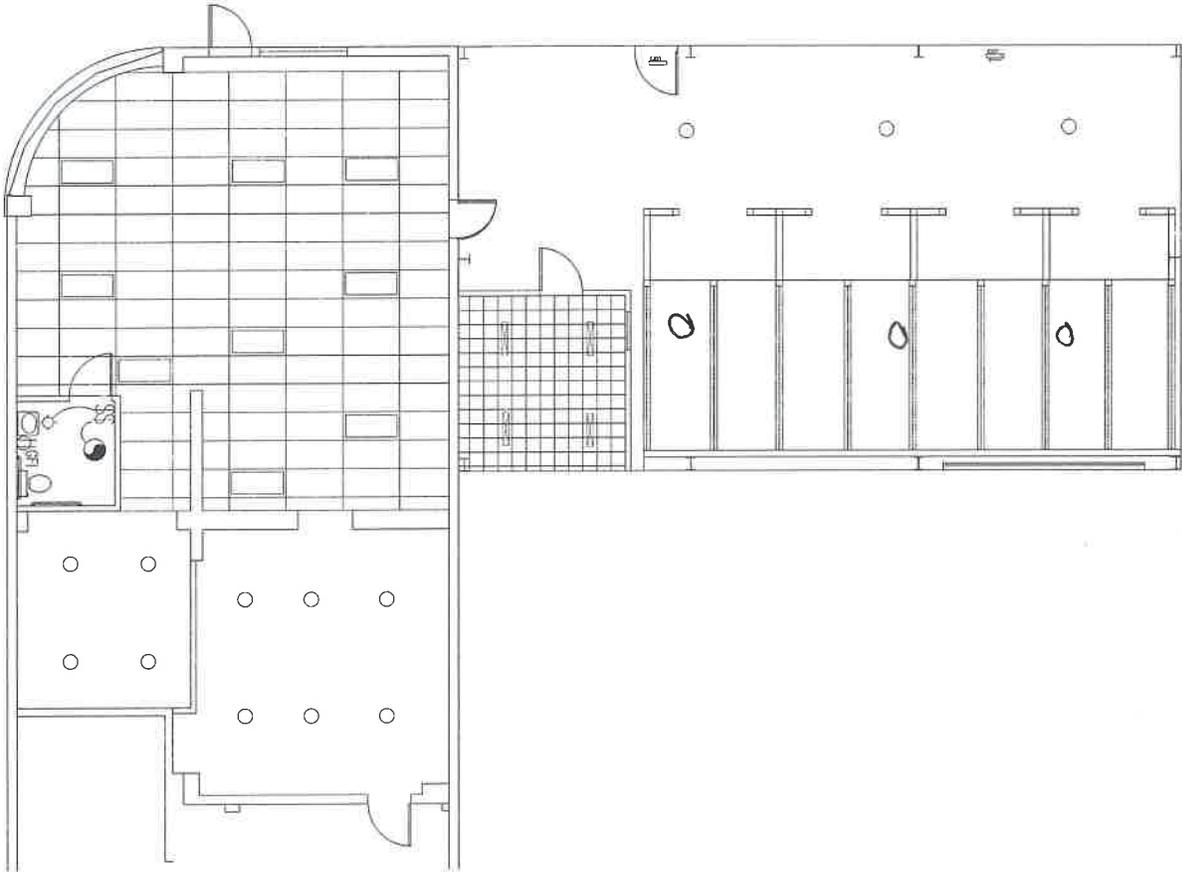

ELECTRICAL SCHEDULE	
§	GENERAL WALL SWITCH
§	DIMMER GENERAL WALL SWITCH
7' x 1' 6" SQUARE	7' x 1' 6" SQUARE CEILING GRID
7' x 1' 6" SQUARE	7' x 1' 6" SQUARE DOWN LIGHT
○	RECESSED LED DOWN LIGHT TRIMMER
⊗	LED DOWN LIGHT TRIMMER
□	LED SURFACE MOUNT 4' LIGHT FIXTURE
○	VENTILATION FAN/EXHAUSTION LIGHT FIXTURE
⊕	EXIT LIGHTS WITH BATTERY BACKUP
⊕	LED SURFACE MOUNT DOWN LIGHT TRIMMER

# REFLECTED CEILING PLAN

SCALE = 1/4" = 1'-0"  
 OLD OROVILLE FORD DEALERSHIP  
 1726 MONTGOMERY STREET, SUITE 2, OROVILLE, CA

JOB NUMBER OZONE, SUITE 2 SHEET NO <b>A5</b>	Reflected Ceiling Plans	drawn by DGA checked	David G. Anderson, Architect 41 Butte Woods Drive, Oroville, California 95966 Phone (530) 693-4546 Cell (530) 520-0211. E-mail dgaarchitect@bcglobal.net		
		date 3/14/2022			



# City of Oroville

## COMMUNITY DEVELOPMENT DEPARTMENT

1735 Montgomery Street

Oroville, CA 95965-4897

(530) 538-2430 FAX (530) 538-2426

[www.cityoforoville.org](http://www.cityoforoville.org)

## Zoning Code Interpretation

### Zoning Codes 17.40.020 (Public or quasi-public facilities) & 17.44.110 (Arts, culture and entertainment overlay)

The Arts, culture, and entertainment overlay (ACE-O) aims to revitalize the historic downtown area as a recreational, community, and tourist destination. As-of-right uses in the ACE-O district explicitly include dance, painting, gymnastics, martial arts, yoga, and "other related arts or similar activities." The proposed commercial use by applicant Ozone Entertainment is a family friendly activity center which exemplifies the ACE-O goals regarding community, recreation and tourism. Under Oroville Municipal Code 17.08.090 this use has been determined allowable, subject to a **Zoning Clearance and Use Permit**, and provided that:

1 – The property's use is equivalent to the use of one or more allowable uses in the zoning district.

The zoning district for the property, Public or quasi-public facilities (PQ), allows for community and entertainment focused land uses. Such uses include but are not limited to: Carnival, circus, or fair; concert or performance; golf course; and meeting facilities both above and under 10000 square feet of gross floor area.

2 – The proposed use will not involve a higher level of activity, density or intensity than other allowable uses for the district.

3 – The proposed use will meet the purpose and intent of the public or quasi-public facilities district.

4 – The proposed use is consistent with the goals, objectives and policies of the general plan

Ozone Entertainment aims to provide a place for community members to have fun in a safe, clean and drug free environment for kids, teens and adults. Extreme heat in the summer often prevents visitors and community members from comfortably enjoying the outdoor public spaces of Oroville. Lack of supervision may prevent youth from safely enjoying public spaces. Ozone Entertainment will function as an alternative form of community recreation that addresses some of these constraints. This is a unique and innovative way to meet the goals of the public facilities district as well as the arts, culture and entertainment overlay.

This determination is consistent with the PQ zoning district, the ACE-O overlay, and the General Plan.

Date: April 5, 2022

Zoning Administrator: 

## RESOLUTION NO. P2022-09

### A RESOLUTION OF THE OROVILLE PLANNING COMMISSION MAKING FINDINGS AND CONDITIONALLY APPROVING MINOR USE PERMIT UP22-03 FOR OZONE ENTERTINMENT, AN INDOOR COMMERCIAL RECREATIONAL FACILITY AT 1726 MONTGOMERY STREET (APN 012-028-013 & -015)

**WHEREAS**, the City has received an application for the construction of a new indoor commercial recreational facility whose primary attraction is hatchet throwing (APN 012-028-013 & -015); and

**WHEREAS**, The City of Oroville Municipal Code (OMC) Table 17.40.010-1 does not allow Indoor commercial recreational facilities, but that this use is in the Downtown Historic Overlay (DH-O) and the Arts, Entertainment and Culture Overlay (ACE-O), both of which encourage family-friendly activity centers which exemplify the goals of community, recreation and tourism; and

**WHEREAS**, the Planning Commission has determined that this facility will not involve a higher level of activity, density or intensity than other allowable uses in this zone and that this activity will provide a place for community members of all ages to have fun in a clean, safe, drug-free environment; and

**WHEREAS**, the Planning Commission has determined that the sale of beer and wine would not detract from the family-friendly nature of the establishment, and

**WHEREAS**, at a duly noticed public hearing, the Planning Commission considered the comments and concerns of public agencies, property owners, and members of the public who are potentially affected by the approval of the use permit described herein, and also considered the City's staff report regarding the change.

**NOW, THEREFORE, BE IT RESOLVED BY THE PLANNING COMMISSION** as follows:

1. This action has been determined to be exempt from the California Environmental Quality Act (CEQA) review pursuant to Title 14, California Code of Regulations, Section 15301 "Existing Facilities."
2. The Planning Commission approves the findings required by Section 17.48.010 of the Oroville City Code, as described in this Resolution.
3. The conditions of approval below have been deemed necessary to achieve the purposes of the Zoning Code and to promote the general health, safety, and public welfare of the City.

4. Should the applicant seek a permit from the Department of Alcohol Beverage Control and if an overconcentration of establishments selling beer and wine exists in this Census Tract, staff is authorized to prepare and sign a Letter of Public Convenience or Necessity on behalf of the Planning Commission.
5. The Planning Commission approves Use Permit UP 22-03, subject to the conditions in this resolution.

### **Required Findings for Use Permits (OMC 17.48.010)**

- 1. The granting of the permit will not be incompatible with or detrimental to the general health, safety or public welfare of the surrounding area or of the city as a whole.**

*The project will be located in an area surrounded by active commercial development within the Downtown Historic Overlay and the Arts, Entertainment and Culture Overlay. The project has been reviewed and conditioned to minimize or prevent any potential impacts to the general health, safety, or public welfare of the surrounding area and the city as a whole.*

- 2. The proposed use follows sound principles of land use by having a suitable location relative to the community as a whole, as well as to transportation facilities, public services and other land uses in the vicinity.**

*The proposed use will provide a desired commercial product and is located in an area with significant employment and transportation access.*

- 3. Public utilities and facilities, including streets and highways, water and sanitation, are adequate to serve the proposed use or will be made adequate prior to the establishment of the proposed use.**

*All infrastructure is in and available to this existing building. Any utilities not already provided on site or needing repair will be installed by the property owner, subject to all applicable fees and permits.*

- 4. The location, size, design and operating characteristics of the proposed use will be harmonious and compatible with the surrounding neighborhood and will not adversely affect abutting properties.**

*The site plan, design, lighting, landscaping, and other improvements have been reviewed and the project conditioned to minimize any adverse impacts on*

*abutting properties. Code enforcement will monitor for compliance on an ongoing basis.*

**5. The subject site is physically suitable for the type and intensity of land use being proposed.**

*Applicant has submitted a set of drawings and enough operating information to demonstrate that the site is physically suitable for the proposed type and intensity of use. The site will provide adequate capacity for the use.*

**6. The size, intensity and location of the proposed use will provide services that are necessary or desirable for the neighborhood and community as a whole.**

*This proposed indoor recreational use will draw visitors and patrons to the downtown area, which is desirable and will help with revitalization in the area and the community as a whole.*

**7. The permit complies with all applicable laws and regulations, including the requirements of the general plan, of this title and of the city municipal code.**

*This use is not currently permitted in the PQ Zone, but subject to a use permit the Planning Commission has determined under OMC 17.08.090 that this use is no more intense than other allowable uses in that Zone, and will otherwise be consistent with the goals, objective and policies of the General Plan, Zoning codes, and the two Zoning Overlays.*

**CONDITIONS OF APPROVAL**

**Approved project:** The Planning Commission hereby conditionally approves Use Permit No. 22-03 for the establishment of an indoor recreational facility at 1726 Montgomery Street (APN 12-028-015). This is an indoor activity in an existing building, but also may include Segway® rentals and/or beer and wine sales. The subject property has a zoning designation of Public Quasi Public (PQ). Per OMC 17.08.090, the Planning Commission has determined that this use is compatible with the purpose and intent of the PQ zone and the goals of the Downtown Historic Overlay and the Arts, Entertainment and Culture Overlay.

**CONDITIONS OF APPROVAL**

**Prior to and during site grading.**

1. Any exterior grading, paving, excavation and site clearance, including that which is exempt from obtaining a permit, shall be performed in conformance with the City’s Engineering

Design Standards; the Municipal Code; the requirements of the State Regional Water Quality Control Board; and any other applicable local, state, and federal requirements.

**Prior to the issuance of building permits.**

1. Applicable construction plans, calculations, specifications, applications, forms, etc. shall be submitted to the Building Division for review prior to the start of any construction activities requiring a building permit. All applicable plan review and impact fees shall be paid at time of submittal.
2. Landscape plans shall be approved by the Parks and Trees Department.
  - I. Parking lots shall meet the 50% shade factor prior to occupancy in accordance with City Code §17.12.050.
3. The building plans shall include an architecturally compatible method of screening any roof mounted HVAC system, or if the units are placed on the ground, the unit shall be screened by landscaping or a decorative fence.

**Prior to and during construction.**

1. The developer will be responsible for the cost of all water improvements (meters, boxes, valves, lines, backflow devices, etc.), which are required to meet Cal Water water service improvement standards. The cost of all fire lines and hydrants shall also be the developer's responsibility.

**Prior to occupancy.**

1. A refuse collection enclosure shall be provided in accordance with City Code 17.12.110. The refuse area shall be covered and large enough to provide adequate storage for solid waste and recyclable materials generated by the development. In addition, a roof cover shall be provided for the enclosure.

**Other.**

1. The applicant shall submit a separate building permit application for any signage. All signage shall be designed and maintained according to the Oroville Sign Code and the approved sign program submitted as part of the use permit application under file No. DRC 22-01/UP22-01, and Trakit file No. PL2112-007 date stamped January 28, 2022.
2. Should the applicant seek a permit from the Department of Alcohol Beverage Control and if an overconcentration of establishments selling on premise beer and wine exists in this Census Tract, staff is authorized to prepare and sign a Letter of Public Convenience or Necessity on behalf of the Planning Commission. Applicant may request such a letter at that time. If a different type of license is sought, applicant must file for a Use Permit Modification.

**General Conditions.**

1. The applicants and any tenants or subsequent owners shall have a current City of Oroville business license and any other applicable permit/license that may be required as part of their business operations.

2. The applicant and any tenants shall ascertain and comply with all requirements of the Butte County Environmental Health Department.
3. The proposed use shall substantially conform to the project description and submitted plans for the project under file No UP22-03, and Trakit file No. PL2205-02 date stamped May 9, 2022. Minor changes may be approved administratively by the Community Development Director or designee upon receipt of a written request by the applicant or designee. Changes deemed to be major or significant in nature shall require a formal application for amendment.
4. Pursuant to Section 17.12.010, the buildings shall conform to the performance standards of the Oroville Municipal Code to minimize any potential negative effects that the buildings, structures, lighting or use could have on its surroundings, and to promote compatibility with surrounding uses and areas.
5. Applicant and/or property owner will take appropriate measures to provide property maintenance of the building exterior, including provisions to keep the premise free of litter and debris.
6. Applicant and/or property owner shall ensure adequate lighting of exterior areas, including parking lots, to discourage loitering outside of the buildings.
7. Applicant and/or property owner will ensure protection of adjacent properties from noise, odors and undue light and glare, as well as illegal activity.
8. Applicant and/or property owner will maintain adequate onsite security, both inside and outside the building, to satisfy any concerns raised by the chief of police or general public. Substantial camera surveillance will suffice.
9. All private facilities, improvements, infrastructure, systems, equipment, common areas, etc. shall be operated and maintained by the applicant and/or property owner in such a manner, and with such frequency, to ensure the public health, safety and general welfare.
10. Pursuant to Section 17.12.050, landscaped areas shall be continually maintained in good condition and shall be kept clean and weeded and trees shall be pruned in a natural pattern and shall not be topped or pollarded. Maintenance shall include but not be limited to:
  - I. Cultivation of planting beds and mowing to maintain grassy areas.
  - II. Pruning of plants as necessary to control and direct growth.
  - III. Replacement of dead or unhealthy plant material in accordance with the approved landscaping plan.
  - IV. Fertilization as needed to ensure proper plant growth.
  - V. Repair or replacement of irrigation system components and irrigation drainage components, as needed, to maintain the system in good working condition.
11. Applicant shall monitor occupancy and will institute controls to limit the number of patrons both inside of the building and outside of the building.
12. The project shall comply with the City's noise ordinance as found in the OMC Chapter 9.20.
13. The applicant shall ascertain and comply with the requirements of all City, County, State, Federal, and other local agencies as applicable to the proposed project.

14. Pursuant to Section 17.48.010(F) of the City Code, the Planning Commission, upon its own motion, may modify or revoke any use permit that has been granted pursuant to the provisions of this section upon finding any of the following, based on substantial evidence:

- I. Any of the conditions of the permit have not been satisfied within 1 year after it was granted.
- II. Any of the terms or conditions of the permit have been violated.
- III. A law, including any requirement in the Municipal Code Chapter 17, has been violated in connection with the permit.
- IV. The permit was obtained by fraud.

15. Applicant hereby certifies that any and all statements and information provided as part of the application are true and correct to the best of their knowledge and belief. Any misinformation provided, whether intentional or unintentional, that was considered in the issuance of this permit may be grounds for revocation.

16. The applicant shall hold harmless the City, its Council members, Planning Commissioners, officers, agents, employees, and representatives from liability for any award, damages, costs, and/or fees incurred by the City and/or awarded to any plaintiff in an action challenging the validity of this permit or any environmental or other documentation related to approval of this permit. Applicant further agrees to provide defense for the City in any such action.

\*\*\*\*\*

**I HEREBY CERTIFY** that the foregoing resolution was duly introduced and passed at a regular meeting of the Planning Commission of the City of Oroville held on the 24<sup>th</sup> of February 2022, by the following vote:

AYES:

NOES:

ABSTAIN:

ABSENT:

ATTEST:

APPROVE:

\_\_\_\_\_  
JACKIE GLOVER, ASSISTANT CITY CLERK

\_\_\_\_\_  
CARL DURLING, CHAIRPERSON



# City of Oroville

**COMMUNITY DEVELOPMENT DEPARTMENT**

**LEONARDO DEPAOLA**  
DIRECTOR

1735 Montgomery Street  
Oroville, CA 95965-4897  
(530) 538-2430 FAX (530) 538-2426  
[www.cityoforoville.org](http://www.cityoforoville.org)

## NOTICE OF EXEMPTION

:	<b>TO</b>	Butte County Clerk	:	<b>FROM</b>	City of Oroville
		25 County Center Drive Oroville, CA 95965			1735 Montgomery Street Oroville, CA 95965

Project Title: PL2205-02 Ozone Indoor Entertainment Commercial Recreational Facility

Project Location – Specific: 1726 Montgomery Street (APN 012-028-015)

Project Location - City: City of Oroville

Project Location – County: Butte

Description of Nature, Purpose, and beneficiaries of project: Ozone Entertainment is a proposed indoor entertainment facility, with hatchet throwing as its main attraction. The venue will be offering Segway and bicycle rentals, prepackaged food and beer and wine (no hard alcohol), and other indoor entertainment. The building is on the corner of Safford and Oak streets, adjacent to and behind the Ford dealership on Montgomery Street. No exterior façade changes or signage has been proposed as part of this Use Permit, but the façade improvements planned for the Ford dealership will include the Ozone Entertainment building in a later phase.

Name of Public Agency Approving Project: City of Oroville

Name of Person or Agency Carrying Out Project: Ozone Entertainment, LLC

Exempt Status (Check One):

- Ministerial (Sec. 21080(b)(1); 15268)
- Declared Emergency (Sec. 21080(b)(3); 15269(a))
- Emergency Project (Sec. 21080(b)(4); 15269(b)(c))
- Categorical Exemption: State type & section number:
  - Existing Facilities, Title 14, CCR, §15301
- Statutory Exemption: State code number:

Reasons why project is exempt: This action has been determined to be exempt from the California Environmental Quality Act (CEQA) review as follows:

Existing Facilities, Title 14, CCR, §15301

Class 1 categorical exemptions consist of the operation, repair, maintenance, permitting, leasing,

licensing, or minor alteration of existing public or private structures. This includes restoration or rehabilitation of deteriorated or damaged structures, and also includes additions to existing structures of less than 50% of the floor area or 2,500 square feet whichever is less. Ozone Entertainment is only making tenant improvements to the interior, and minor façade updates.

If filed by applicant:

- 1. Attach certified document of exemption finding.
- 2. Has a notice of exemption been filed by the public agency approving the project?  Yes  No

Lead Agency Contact Person: Wes Ervin, Principal Planner

Telephone: (530) 538-2408

Signature: \_\_\_\_\_

Date: \_\_\_\_\_

- Signed by Lead Agency
- Signed by Applicant



# City of Oroville

**Dawn Nevers**  
Assistant Director

## COMMUNITY DEVELOPMENT DEPARTMENT

1735 Montgomery Street  
Oroville, CA 95965-4897  
(530) 538-2430 FAX (530) 538-2426  
[www.cityoforoville.org](http://www.cityoforoville.org)

### PLANNING COMMISSION STAFF REPORT

Thursday, June 23, 2022

**RE: General Plan Amendment and Rezone from Public-Quasi Public to Downtown Mixed-Use of 21 parcels fronting Lincoln Street, Broderick Street, Oak Street and Safford street.**

**SUMMARY:** The Oroville Planning Commission may review and consider recommending that the City Council approve General Plan Amendment GPA 22-01 and Zoning Code Amendment ZC 22-03 for twenty-one parcels on Lincoln, Safford, Oak and Broderick. (APN's 012-021-008, -011, -012, -015, -018, -020, -021, -022, -023, -028, -029 AND APN's 012-028-003, -004, -005, -006, -007, -008, -009, -015, -016, AND APN 012-031-008).

**RECOMMENDATION: Staff recommends the following actions:**

**1. Recommend that the City Council:**

- a. Certify the Notice of Exemption
- b. Approve General Plan Amendment GPA 22-01
- c. Adopt Zoning Change ZC 22-03

**Adopt Resolution No. P2022-07 -- A RESOLUTION OF INTENTION BY THE OROVILLE PLANNING COMMISSION RECOMMENDING THE CITY COUNCIL ADOPT GENERAL PLAN AMENDMENT 21-04 AND ZONING CODE AMENDMENT ZC 22-03 TO CHANGE THE LAND USE DESIGNATION OF 21 PARCELS ON SAFFORD, BRODERICK, OAK AND LINCOLN STREETS TO MIXED USE AND THE ZONING TO DOWNTOWN MIXED-USE (APN's 012-021-008, -011, -012, -015, -018, -020, -021, -022, -023, -028, -029 AND APN's 012-028-003, -004, -005, -006, -007, -008, -009, -015, -016, AND APN 012-031-008).**

**APPLICANTS:** Initiated by City of Oroville

**LOCATION:** Convergence of Lincoln, Safford, Oak and Broderick streets.

**GENERAL PLAN:** PARK  
**ZONING:** PQ (Public Quasi-Public)  
**FLOOD ZONE:** Zone X

**ENVIRONMENTAL DETERMINATION:** Exempt as "Existing Facilities" and "Infill Project".

**REPORT PREPARED BY:**

**REVIEWED BY:**

\_\_\_\_\_  
Daniel Kopshever, Assistant Planner  
Community Development Department

\_\_\_\_\_  
Dawn Nevers, Assistant Director  
Community Development Department

## **DISCUSSION**

The city has initiated this general plan amendment (GPA 22-01) to Mixed Use (MU), and Zone Change (ZC 22-03) to Downtown Mixed-Use. This change is more consistent with the zoning of the surrounding land uses and allows the return of commercial activity to the site after being vacant for several years. The area, which comprises about 2.56 acres, was previously planned to be developed as a public plaza in the General Plan and was zoned accordingly, but that development is longer planned. The City's action will help expedite revitalization of the area, with Mr. Mendez stepping forward to do so.

Mark Mendez, a local developer has acquired or seeks to acquire all the parcels in this action. His intent is to redevelop the former Ford dealership into several small office and commercial projects. Each project as it is proposed will be reviewed for compliance to CEQA, to the Oroville Municipal Code and to the Building Code prior to approval. Use permits are known to be needed for at least two of the likely projects.

## **ENVIRONMENTAL**

This project is exempt under CEQA as both "Existing Facilities on block which housed the former Ford Dealership, and as "Infill" on the vacant parcels to the north.

## **FISCAL IMPACT**

None. The city has initiated this change.

## **PUBLIC NOTICE**

A request for comments was prepared and circulated to the local agencies and surrounding property owners within 300 feet of the properties. Additionally, the meeting date, time, and project description were published in the Oroville Mercury Register and posted at City Hall.

## **SUMMARY**

Staff recommends the Commission forward a recommendation for City Council approval of the General Plan Amendment and Zoning Change.

## **ATTACHMENTS**

1. Map and aerial showing affected parcels
2. Resolution of Intention P2202-07 recommending to Council the GPA and ZC approvals.
3. Draft Ordinance with Rezone
4. Notice of Exemption



# City of Oroville

## COMMUNITY DEVELOPMENT DEPARTMENT

Item 3.

**Dawn Nevers**  
ASSISTANT DIRECTOR

1735 Montgomery Street  
Oroville, CA 95965-4897  
(530) 538-2430 FAX (530) 538-2426  
[www.cityoforoville.org](http://www.cityoforoville.org)

### **ATTENTION: PROPERTY OWNERS AND INTERESTED PARTIES**

The project listed below has been filed with the Planning Division. You are invited to comment because your property is located near the proposed project, or you are an agency with potential interest in the project. Application materials are available for review at City Hall at the above address. Please comment in the space below. You may attach additional pages as necessary. If you have no comments, a reply is not necessary.

Please submit any comments to this department no later than **Tuesday, June 16, 2022** to be sure that they are included in the final project action. However, comments will be taken up to the time of the project decision. Please refer to this project by the Applicant's name and the Assessor Parcel Number indicated below. If you have no comment, a reply is not necessary.

### VICINITY MAP

**ASSESSOR PARCEL NUMBER:** 012-028-015, 012-028-016  
012-028-003, 012-028-004  
012-028-005, 012-028-006  
012-028-008, 012-028-009  
012-028-007, 012-031-008  
012-021-008, 012-021-028  
012-021-011, 012-021-012  
012-021-022, 012-021-023  
012-021-015, 012-021-029  
012-021-018, 012-021-020  
012-021-021



**FILE NUMBER:** GPA 21-04 & ZC 22-03

**APPLICANT:** City of Oroville

**ZONING:** PQ (Public Quasi Public)

**Proposed MXD (Downtown Mixed-Use)**

**LOCATION:** Safford, Lincoln, Oak and Broderick Streets

**CONTACT PERSON:** Daniel Kopshever

Assistant Planner  
530 538-2430

[dkopshever@cityoforoville.org](mailto:dkopshever@cityoforoville.org)

### **PROJECT DESCRIPTION:**

**GPA 21-04, & ZC 22-03 (a)** - The City of Oroville Planning Commission will conduct a public hearing to consider a General Plan Amendment and Rezoning of the above addresses to MXD (Downtown Mixed-Use) to be consistent with the City's standard zoning for the downtown area. This location had been zoned PQ in anticipation of a public open space plaza that will no longer be moving forward. This rezone is initiated by the city.

**NOTICE IS HEREBY GIVEN** that the City of Oroville Planning Commission will hold a public hearing on the project described above. Said hearing will be held at **6:00 pm on Thursday, June 23, 2022** in the City Council Chambers, 1735 Montgomery Street, Oroville, CA. All interested persons are invited to attend and/or submit comments in writing.



**COMMENTS AND/OR RECOMMENDED CONDITIONS OF APPROVAL** (Please attach additional pages, if needed):

---

---

---

---

---

---

---

---

---

---

---

Signature: \_\_\_\_\_

Date: \_\_\_\_\_

Agency/Affiliation: \_\_\_\_\_

***PLEASE RETURN COMPLETED FORM to 1735 Montgomery Street, Oroville  
95965 or CALL THE CITY OF OROVILLE PLANNING DIVISION (530) 538-2430***

**RESOLUTION NO. P2022-07**

**A RESOLUTION OF INTENTION BY THE OROVILLE PLANNING COMMISSION RECOMMENDING THE CITY COUNCIL ADOPT GENERAL PLAN AMENDMENT 21-04 AND ZONING CODE AMENDMENT ZC 22-03 TO CHANGE THE LAND USE DESIGNATION OF 21 PARCELS ON SAFFORD, BRODERICK, OAK AND LINCOLN STREETS TO MIXED USE AND THE ZONING TO DOWNTOWN MIXED-USE (APN's 012-021-008, -011, -012, -015, -018, -020, -021, -022, -023, -028, -029 AND APN's 012-028-003, -004, -005, -006, -007, -008, -009, -015, -016, AND APN 012-031-008).**

**WHEREAS**, the City of Oroville has determined that these parcels are no longer planned for public space as outlined in the 2015 adopted General Plan; and

**WHEREAS**, the City has determined that the parcels are more suited to mixed use commercial and residential purposes;

**WHEREAS**, the surrounding areas are primarily zoned downtown mixed-use; and

**WHEREAS**, the City is keenly interested in supporting revitalization of the area, and a rezone will encourage that revitalization; and

**WHEREAS**, the City has initiated this general plan amendment and rezone to allow this group of parcels to have the same rights and privileges as those afforded to other similarly zoned nearby properties in the downtown; and

**WHEREAS**, at a duly noticed public hearing, the Planning Commission considered the comments and concerns of public agencies, property owners, and members of the public who are potentially affected by the changes described herein, and also considered the City's staff report regarding the change.

**NOW, THEREFORE, BE IT RESOLVED BY THE PLANNING COMMISSION** as follows:

1. This action has been determined to be exempt from California Environmental Quality Act (CEQA) review pursuant to Title 14, California Code of Regulations, Section 15332 "Infill Development Projects" for a portion and Section 15061(b)(3) General Rule Exemption" for another portion.
2. The Planning Commission recommends that the City Council adopt General Plan Amendment (GPA) 22-01 and Zoning Change (ZC) 22-03.
3. The Planning Commission recommends that the City Council direct the preparation and adoption of one or more ordinances as necessary to amend the City of Oroville Zoning Map to affect the necessary zoning changes.
4. For any new development, the property owner and any subsequent owners must obtain all required permits from the City and any responsible agencies, and implement the conditions of those permits.

**I HEREBY CERTIFY** that the foregoing resolution was duly introduced and passed at a regular meeting of the Planning Commission of the City of Oroville held on the 23<sup>th</sup> of June 2022, by the following vote:

AYES:

NOES:

ABSTAIN:

ABSENT:

ATTEST:

APPROVE:

\_\_\_\_\_  
JACKIE GLOVER, ASSISTANT CITY CLERK

\_\_\_\_\_  
CARL DURLING, CHAIRPERSON

**CITY OF OROVILLE  
ORDINANCE NO. XXXX**

**AN ORDINANCE OF THE CITY COUNCIL OF THE CITY OF OROVILLE APPROVING ZONING CHANGE ZC 22-03 TO REZONE APPROXIMATELY 2.56 ACRES OF LAND COMPRISING 21 PARCELS ON SAFFORD, BRODERICK, OAK AND LINCOLN STREETS TO DOWNTOWN MIXED-USE (APN's 012-021-008, -011, -012, -015, -018, -020, -021, -022, -023, -028, -029 AND APN's 012-028-003, -004, -005, -006, -007, -008, -009, -015, -016, AND APN 012-031-008).**

**WHEREAS**, the City of Oroville has determined that these parcels are no longer planned for public space as outlined in the 2015 adopted General Plan; and

**WHEREAS**, the City has determined that the parcels are more suited to mixed use commercial and residential purposes;

**WHEREAS**, the surrounding areas are primarily zoned downtown mixed-use; and

**WHEREAS**, the city is keenly interested in supporting revitalization of the area, and a rezone will encourage that revitalization; and

**WHEREAS**, the City has initiated this general plan amendment and rezone to allow this group of parcels to have the same rights and privileges as those afforded to other similarly zoned nearby properties in the downtown; and

**WHEREAS**, at a duly noticed public hearing, the City Council considered the comments and concerns of public agencies, property owners, and members of the public who are potentially affected by the changes described herein, and also considered the City's staff report regarding the change.

**The Council of the City of Oroville do ordain as follows:**

Section 1. Pursuant to section 17.08.040 of the Code of the City of Oroville, approximately 2.56 acres of land constituting 21 parcels on Safford, Broderick, Oak and Lincoln Streets (APN's 012-021-008, -011, -012, -015, -018, -020, -021, -022, -023, -028, -029 and APN's 012-028-003, -004, -005, -006, -007, -008, -009, -015, -016, and APN 012-031-008) are hereby rezoned to Downtown Mixed Use (MXD).

Section 2. This ordinance shall become effective on September 3, 2022, or 30 days after the second reading is approved, whichever comes later.

Section 3. The City Clerk shall attest to the adoption of this ordinance.

PASSED AND ADOPTED by the City Council of the City of Oroville at a regular meeting held on July 19, 2022, by the following vote:

AYES:

NOES:

ABSENT:

ABSTAIN:

\_\_\_\_\_  
Mayor, Chuck Reynolds

APPROVED AS TO FORM: ATTEST:

\_\_\_\_\_  
City Attorney, Scott E Huber

\_\_\_\_\_  
City Clerk, Jackie Glover



# City of Oroville

## COMMUNITY DEVELOPMENT DEPARTMENT

1735 Montgomery Street  
Oroville, CA 95965-4897  
(530) 538-2430 FAX (530) 538-2426  
[www.cityoforoville.org](http://www.cityoforoville.org)

### NOTICE OF EXEMPTION

TO	Butte County Clerk	FROM	City of Oroville
:	25 County Center Drive	:	1735 Montgomery Street
	Oroville, CA 95965		Oroville, CA 95965

Project Title: General Plan amendment and Rezone of 21 urban downtown parcels from Public-Quasi Public to Downtown MIXED-USE (APN's 012-021-008, -011, -012, -015, -018, -020, -021, -022, -023, -028, -029 AND APN's 012-028-003, -004, -005, -006, -007, -008, -009, -015, -016, AND APN 012-031-008).

Project Location – Specific: At the convergence of Safford, Broderick, Oak And Lincoln Streets

Project Location - City: City of Oroville

Project Location – County: Butte

Description of Nature, Purpose, and beneficiaries of project: The city has initiated this general plan amendment (GPA 22-01) to Mixed Use (MU), and Zone Change (ZC 22-03) to Downtown Mixed-Use. This change is more consistent with the zoning of the surrounding land uses and allows the return of commercial activity to the site after being vacant for several years. The area, which comprises about 2.56 acres, was previously planned to be developed as a public plaza in the General Plan and was zoned accordingly, but that development is longer planned. The City's action will help expedite revitalization of the area, with Mr. Mendez stepping forward to do so.

Name of Public Agency Approving Project: City of Oroville

Name of Person or Agency Carrying Out Project: Ozone Entertainment, LLC

Exempt Status (Check One):

- Ministerial (Sec. 21080(b)(1); 15268)
- Declared Emergency (Sec. 21080(b)(3); 15269(a))
- Emergency Project (Sec. 21080(b)(4); 15269(b)(c))
- Categorical Exemption: State type & section number:
  - Existing Facilities, Title 14, CCR, §15301
  - In-Fill Development Projects, Title 14 CCR, §15332
- Statutory Exemption: State code number:

Reasons why project is exempt: This action has been determined to be exempt from the California Environmental Quality Act (CEQA) review as follows:

Existing Facilities, Title 14, CCR, §15301

Class 1 categorical exemptions consist of the operation, repair, maintenance, permitting, leasing, licensing, or minor alteration of existing public or private structures. This includes restoration or rehabilitation of deteriorated or damaged structures, and also includes additions to existing structures of less than 50% of the floor area or 2,500 square feet whichever is less. Nine of the parcels are fully developed under an abandoned Ford dealership, and would be rehabilitated.

In-Fill Development Projects; Title 14, CCR, §15332

Class 32 categorical exemptions consists of projects characterized as in-fill development meeting specific conditions a-e as described in this section. Twelve of the parcels are vacant but surrounded by development on at least three sides. All are located in the Downtown Historic Overlay and are considered fully urbanized. This project meets all conditions, including that it occurs within City limits, has no value as habitat, will not result in any significant effects, and can be adequately served by all required utilities. Any development that would occur on the vacant parcels would meet all requirements of the MXC zoning designation.

If filed by applicant:

- 1. Attach certified document of exemption finding.
- 2. Has a notice of exemption been filed by the public agency approving the project?  Yes  No

Lead Agency Contact Person: Wes Ervin, Principal Planner

Telephone: (530) 538-2408

Signature: \_\_\_\_\_

Date: \_\_\_\_\_

- Signed by Lead Agency
- Signed by Applicant



# City of Oroville

## COMMUNITY DEVELOPMENT DEPARTMENT

1735 Montgomery Street  
 Oroville, CA 95965-4897  
 (530) 538-2436 FAX (530) 538-2426  
[www.cityoforoville.org](http://www.cityoforoville.org)

### PLANNING COMMISSION STAFF REPORT

Thursday, June 23, 2022

**RE: Housing element Update (2022-2030)**

**SUMMARY:** The Planning Commission may conduct a public hearing to review the Draft 2022 General Plan Housing Element Update and make recommendations to the City Council regarding its adoption.

**RECOMMENDATION: Staff recommends the following actions:**

1. **Conduct a public hearing regarding the Housing Element**
2. **Adopt a resolution of intention recommending that the City Council:**
  - a. **Determine that the Housing Element is exempt from environmental review under CEQA, and**
  - b. **Adopt the Draft Element and**
  - c. **Authorize submittal to the California Department of Housing and Community Development (HCD) for their certification.**

**APPLICANTS:** Initiated by City staff

**LOCATION:** city-wide

**GENERAL PLAN:** NA

**ZONING:** NA

**FLOOD ZONE:** NA

**ENVIRONMENTAL DETERMINATION:** Exempt from environmental review under CEQA Guidelines Section 15061(b)(3), General Rule Exemption.

**REPORT PREPARED BY:**

\_\_\_\_\_  
 Wes Ervin, Principal Planner  
 Community Development Department

**REVIEWED BY:**

\_\_\_\_\_  
 Dawn Nevers, Assistant Director  
 Community Development Department

## **DISCUSSION**

State law requires each jurisdiction to update its Housing Element (one of the nine required elements of a General Plan) every eight years with specific deadlines established by the California Department of Housing and Community Development (HCD). The City of Oroville is required to submit its updated “Sixth Cycle” Housing Element to the State for certification in June 2022.

The Housing Element provides an analysis of a community’s housing needs for all income levels, along with strategies and actions for responding to those needs. Unlike other elements in the General Plan, the Housing Element is required to be updated every eight years, which allows it to be more responsive to a rapidly changing housing market. The Housing Element is considered the primary policy document to guide the development, rehabilitation, and preservation of housing for all economic segments of the City’s population. California law also specifies that for the private market to adequately address housing needs and demand, local governments must adopt land use plans and regulatory systems which provide opportunities for and do not unduly constrain housing development. It also establishes that each city and county accommodate its fair share of affordable and market rate housing. The Draft Housing Element is available for review at: [www.orovillehousingelement.com](http://www.orovillehousingelement.com)

### **Regional Housing Needs Allocation (RHNA)**

State law requires regions to plan for housing needs based on future growth projections through the Regional Housing Needs Allocation (RHNA) process. HCD allocates a numeric RHNA goal to regional planning organizations. Butte County’s regional planning organization is the Butte County Association of Governments (BCAG), which coordinated with and provided each Butte County jurisdiction with its “fair share” RHNA goal. The RHNA goals identify housing units needed to accommodate growth during the planning period for each of four different income levels: Very Low (includes Extremely Low), Low, Moderate and Above Moderate. Communities must use planning and funding mechanisms that enable them to achieve the RHNA goals, including the Adequate Sites Inventory to ensure that there is an adequate supply of appropriately zoned land within its jurisdiction to accommodate its RHNA. (*pages 199-204* of the Housing Element).

### **HCD Courtesy Review and Formal Certification**

The project team coordinated an informal pre-review of the Draft Housing Element with HCD staff and incorporated changes to address comments received. Following formal City submittal of the adopted Draft Housing Element to the State, HCD has up to 90 days to review and issue comments or a certification.

### **New State Legislation affecting the 6<sup>th</sup> Cycle**

There are several new housing laws and HCD review requirements that have been added since the last Housing Element update was completed in 2014. These include:

- 1) New laws limiting a jurisdictions' ability to restrict the development of Accessory Dwelling Units (ADUs), that an ADU counts to satisfy RHNA goals, and that a Housing Element include a plan to incentivize and promote the creation of ADUs that can offer affordable rents for very low-, low- and moderate-income households. **Staff will soon update existing City codes to these new requirements.**
- 2) Any new Housing Element must contain an Assessment of Fair Housing that includes actions that promote and affirmatively further fair housing opportunities through the community as required through AB 686. **Chapter 4 is that assessment, with various findings on Pages 63, 91, 97, 125, & 153 and a Summary on Pages 210-213. Policies and Goals to address the findings are in Chapter 3.**
- 3) Another law outlines the need for "No Net Loss" (SB 166), that requires jurisdictions to at all times maintain adequate sites to accommodate their unmet Regional Housing Needs Allocation by income category. **See Pages 201-204 for Oroville's proposed site inventory.**
- 4) The site inventory and other housing sites must be adequately zoned and planned with adequate infrastructure, locations, suitability for development, and other requirements.
- 5) A number of laws pertaining to Emergency Shelters, Low Barrier Navigation Centers, Transitional Housing and Supportive Housing. These laws are intended to reduce or remove governmental constraints to the development of these types of special needs housing.

### **Required Contents of the Draft Housing Element**

This Housing Element update covers the eight-year period from June 2022 to June 2030. It complies with State legislation regarding required components of a Housing Element and the requisite analysis. Key Housing Element components must address the following issues:

- Review of the progress and effectiveness of the previous Housing Element **(Chapter 2)**;
- Analysis of all economic segments of the community in the planning process and their access to various services and economic opportunities **(in Chapter 4)**;
- Assessment of housing needs, including those of special needs populations, such as seniors, individuals experiencing homelessness, female-headed households, large households, and persons with disabilities (Affirmatively Furthering Fair Housing) **(in Chapter 4)**.
- Assessment of fair housing issues and trends, contributing factors to these issues and trends, as well as the local jurisdiction's fair housing enforcement and capacity **(in Chapter 4)**;
- Identification of units at risk of conversion from restricted rents to market rents **(in Chapter 4)**.

- Inventory of whether there are an adequate number of appropriately zoned sites to accommodate growth for all income groups, as projected by the Butte County Association of Governments (**Pages 199-204**);
- Description of available financial and energy efficiency resources (**Chapter 5, Page 215 et seq.**);
- Identification of governmental and non-governmental constraints to housing production (**Chapter 6**); and
- Provision of a housing program with goals, policies, and actions that are consistent with the General Plan and that address housing needs, constraints, and available resources, including any fair housing issues that have been identified. The housing program must include a timeline of actions during the planning period (**Chapter 3**).

### **Goals in the Update – New and Carried Forward**

- New and returning Goals with actions include:
  - Goal 1 - Increasing the availability of permanent housing for all community residents through assistance, new facilities for the homeless, and incentivizing the development of ADU's. (Page 26)
  - Goal 2 - Remove regulatory constraints to housing development, including allowing transitional housing and emergency shelters in all residential districts. Currently transitional housing over 7 beds is allowed only in R-3 and R-4 zoning. (Page 27)
  - Goal 3 – Provide housing that is affordable to low-income households
  - Goal 4 - Support and encourage new housing in all ranges, housing types and costs. Improve rehabilitate and revitalize existing homes and neighborhoods.
  - Goal 5 - Promote energy conservation in residential neighborhoods.
  - Goal 6 - Improve fair housing choice and equitable access to opportunity.

### **Selected Findings in the 2022 Update**

- The city made considerable progress on its 2014 Housing element Programs, even given limited resources and an economic downturn (Page 25)
- Oroville's population grew by 25% between 2010 and 2019 – an exponential increase. Diversity has increased substantially, with 72% identifying as white and 16.3% as Latino in 2019. This is a change from 75% white and 10.4% Latino in 2010. Other minority groups saw changes, but less significantly. (Page 65).
- 25% of all households (552) held Housing Choice Vouchers in the City. Oroville is the only area in the county with such a high number (page 63).
- 40% of households are headed by single mothers;(Page 91). Household income is lower than for married-couple families (Page 190)

- Over half of 1-person households are renter households, while over half of 2-person households are owner households (Page 193 Figure 37).
- 20-30% of the population is living with a disability (Page 91).
- One in four families is experiencing poverty. In most census tracts 30-40% of the population is living below the poverty level (Page 91).
- Buyers and Renters from all income backgrounds are having trouble finding housing to fit their needs, including small units and accessible units (Page 125)
- More than half of Oroville’s population have household incomes less than \$34,999 which is only enough income to support a studio (Page 153).
- 60-80% of residents in Census Tract 28 (downtown) live in rental units – the highest concentration in town (Page 154).
- Residents of greater Southside pay more than 30% of their incomes towards housing costs. (Page 154)
- Oroville has no areas of concentrated minorities in poverty, but several areas of the city have high levels of segregation and poverty. Nor are there any racially concentrated areas of affluence. (Page 97)
- Nearly all areas of the city are areas of low resource or high segregation and poverty (Page 125).
- Oroville’s housing shortage was exacerbated by the Camp fire and the North Complex Fire after that, which disproportionately affected low-income and senior residents. Many residents are still living in temporary housing such as RV’s and campers (Page 154).
- Commute time is 14 minutes or less for most residents (Page 125);

### **GENERAL PLAN CONSISTENCY**

The Goals, Policies, and Actions in the Housing Element must be consistent with the General Plan and must support and compliment the Goals, Policies, and Actions found throughout the Oroville 2030 General Plan. The policy framework reinforces the overall direction of the General Plan through consistency with the following General Plan Goals:

Goal LU-3: Provide housing in a range of residential densities and types to address the housing needs of all segments of the community, including all income groups expected to reside in Oroville.

Goal LU-3 includes several Policies guiding housing development, including developing multi-family development where appropriate, building cohesive neighborhoods with distinctive characters and parks and access to public and commercial facilities, and developing affordable housing.

In addition, under Oroville Municipal Code 17.04.050(H) all Zoning and other deliberations by the Planning Commission and City Council should “promote, protect

and preserve the general public health, safety and welfare, and to implement the goals and objectives of the General Plan for the City of Oroville”. (Ord. 1749 § 4)

### **FISCAL IMPACT**

None. The Housing element Update was funded using CDBG Program Income funds

### **PUBLIC NOTICE**

A detailed description of the extensive public outreach process during preparation is found on Pages 8-17 of the Draft Element.

The Draft is also now available for public review for 30 days between June 12 and July 12 and can be viewed at <https://www.orovalhoousingelement.com/resources> or at the front counter at City Hall.

In addition, notice of this public hearing appeared on June 11, 2022, in the Oroville Enterprise Record-Mercury register.

### **ATTACHMENTS**

1. Draft 2022-2030 Housing Element Update
2. Resolution of Intention No P2202-08
3. Draft Notice of Exemption

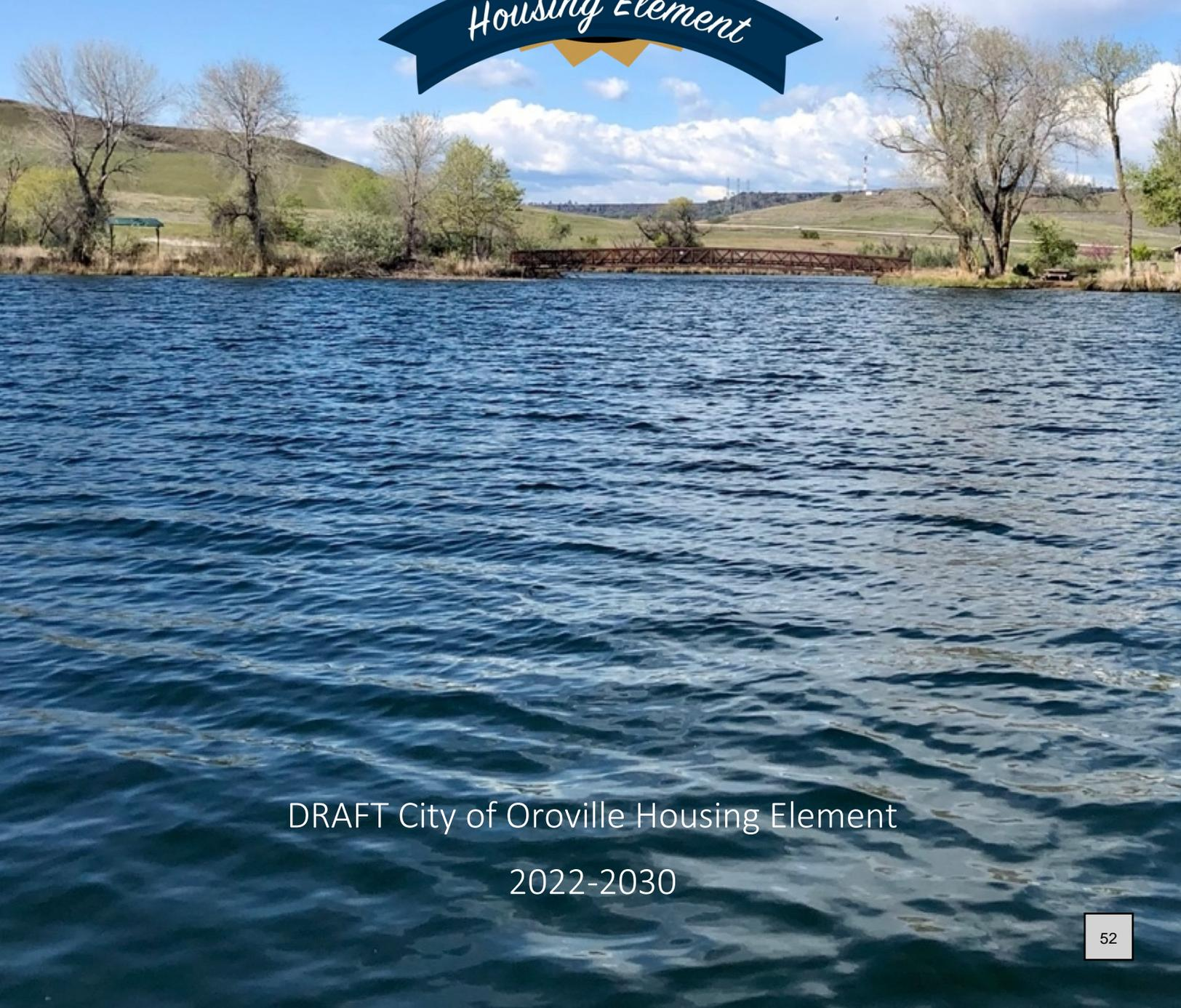

DRAFT City of Oroville Housing Element  
2022-2030

# TABLE OF CONTENTS

Chapter 1: Introduction and Background, Public Participation Process.....3

Chapter 2: Review of Previous Housing Element.....18

Chapter 3: Housing Program .....28

Chapter 4: Housing Needs Assessment.....46

Chapter 5: Resource Inventory.....199

Chapter 6: Constraints Analysis.....223

Appendices:

A: Review of Progress on Previous Housing Element.....270

B: Sites Inventory Form.....281

C: Community Meeting #1 Polls.....283

D: Community Meeting #2 Polls.....286

Cover photo by: J. Candela

# CHAPTER 1: INTRODUCTION AND BACKGROUND

## PURPOSE OF THE HOUSING ELEMENT

---

California requires that all local governments (cities and counties) adequately plan to meet the housing needs of everyone in the community. California's local governments meet this requirement by adopting Housing Elements as part of their General Plan. General Plans serve as the local government's "blueprint" for how the city and/or county will grow and develop over a 15–20-year period and include a minimum of seven mandatory elements: land use, transportation, conservation, noise, open space, safety, and housing. The Housing Element must be consistent with the other elements of the General Plan. General Plans are updated approximately every 20 years, while Housing Elements are on 8-year cycles to ensure relevancy and accuracy, since the housing market and needs are most closely tied to shifts in the economy. The current Oroville Housing Element was adopted in 2014 and covers the period of 2014-2022.

California's Housing Element law acknowledges that in order to address the spectrum of housing needs, local governments must adopt plans and regulatory systems that provide opportunities for and do not unduly constrain housing development. It also establishes that each city and county accommodate their fair share of affordable housing as an approach to distributing housing needs throughout the region and state.

This Housing Element update covers the eight-year period from June 2022-June 2030. It is intended to provide the City of Oroville with a comprehensive strategy to promote the production of safe, decent, and affordable housing for all of its residents. It assesses current and projected housing needs, constraints to housing production, and resources available to meet the needs. It then establishes a set of housing goals, policies, and actions which are targeted to meet the housing needs over the Housing Element planning period. A key part of the Housing Element lays out strategies to address the needs of community residents that are not typically met by the private market, including low-income households, seniors, homeless individuals, and people with disabilities. The City does not generally build or own housing, but facilitates production by guiding zoning policies, coordinating with community partners, and in the case of affordable housing, by partnering with developers, lenders, and nonprofits on funding opportunities.

The Housing Element consists of the following chapters, as required by State regulations:

- Chapter 1 (Introduction and Background) provides an introduction and background to the Housing Element, including its purpose, local context, regulatory framework, a description of the public participation process, and the inter-governmental review process.
- Chapter 2 (Review of Previous Housing Element) reviews the most recent Housing Element for the period 2014-2022 by summarizing its actions and accomplishments, its

affordable housing production goals and results, and the findings from this analysis that are relevant to the 2022-2030 Housing Element Goals, Policies, and Programs.

- Chapter 3 (Goals, Policies, and Program) provides the City’s updated Goals, Policies, and Programs for 2022-2030, along with a Quantified Objectives Summary.
- Chapter 4 (Housing Needs Assessment) provides data and analysis in the following areas: Assessment of Fair Housing, demographics, employment, household characteristics, housing stock characteristics, housing affordability, and the special housing needs of households who are extremely low-income, seniors, persons with a disability, female-headed, large households, people experiencing homelessness, and farmworkers.
- Chapter 5 (Resource Inventory) analyzes sites available to accommodate the City’s share of the Regional Housing Needs Allocation (RHNA) by income level, including the sites’ capacity, environmental constraints, and infrastructure/utility availability. This chapter also describes financial resources available to address the identified needs and opportunities for energy conservation.
- Chapter 6 (Constraints Analysis) assesses the various governmental and market factors that may serve as potential constraints to housing development and improvement in Oroville.
- Appendix A provides a detailed review of the City’s progress on the previous Housing Element, which is summarized in Chapter 2.
- Appendix B is the Sites Inventory Form mandated by the State Department of Housing and Community Development to be submitted with the Housing Element document. Information on these sites used to meet the City’s RHNA is also further described in Chapter 5.

## CONTEXT

---

Since the City’s Housing Element was last updated in 2014, two significant events have occurred that have impacted housing demand and cost, as well as the development of this Housing Element update: the 2018 Camp Fire and the COVID-19 pandemic which began in early 2020.

### *Camp Fire*

The year 2018 was the deadliest year for wildfires in California’s history, with numerous unprecedented wildfires throughout the state. On November 8, 2018, a wildfire which began near Pulga in Butte County quickly spread to the communities west of it, driven by heavy winds and drought conditions. Named the Camp Fire, it largely destroyed the communities of Paradise, Concow, and Magalia, with significant structure loss in Butte Creek Canyon and up to the eastern edge of the City of Chico. It destroyed approximately 14,000 residential units and 85 lives were lost. As noted in the 2020 Peloton Research & Economics report, “The Impacts of the Camp Fire Disaster on Tri-County Housing Markets” are discussed below (the Tri-County region includes the three counties of Butte, Glenn, and Tehama):

- In 2018, the largest cities in the tri-county region were in Butte County; City of Chico (92,861), City of Oroville (18,091) and the Town of Paradise (26,432). Following the Camp Fire, the Town of Paradise experienced a population loss of 82.9% from 2018. During that same time, the City of Oroville saw a 19.1% growth in population. This basically equated to a decade of growth in one year. A very large proportion of residents whose homes burned down fled to Chico and Oroville, the nearest communities that had not suffered physical damage from the wildfire, to seek short-term shelter and long-term housing.
- This sudden population increase placed an enormous strain on Oroville's public infrastructure, including roadways, water systems, and public services such as community support functions and case management.
- At the time of the Camp Fire, the tri-county region was already experiencing a very competitive housing market, with rental vacancy rates of less than 2%, very long wait lists for affordable housing and very limited housing inventory available for sale. After the fire, the rental vacancy rate became less than 0.5%.
- Over the first six months following the disaster, there was a substantial surge that resulted in record-high home prices and rent rates throughout the tri-county region that displaced residents coupled with a shortage of housing, backlog of housing construction, and rapidly rising homelessness.
- One dynamic shift in the housing market which is particularly important to note was the loss of large neighborhoods of naturally occurring, affordable housing in Paradise. Paradise was known to be the most affordable community in Butte County (both for renters and homeowners) and the vast majority of its housing stock was not subsidized. Housing stock consisted of older homes and mobile homes. Replacing these naturally affordable units in today's market, with unprecedented demand and soaring land and construction costs, is a challenge that will take time and effort to overcome.
- Displacement due to the fire affected not only those whose homes were directly destroyed or damaged by the fire, but also the renters whose landlords chose to either sell their rental home to take advantage of higher demand and sales prices, or to rent to a family member or friend who had lost their home. This issue is more fully described and analyzed in the Chapter 4 Needs Assessment.

While this Housing Element update is being prepared three full years after the Camp Fire, the impacts on housing within Oroville have not subsided. There continue to be ongoing challenges with housing inventory, affordability, and displacement.

There are, however, many strides also being made, with the City's receipt of HOME funding for the development of multi-family housing for low-income seniors, which should support the construction of 40 affordable rental units, and the receipt of Disaster Low Income Housing Tax Credits, which will produce 312 affordable multi-family units. More projects are on the horizon, but they will take time to secure land and financing, in addition to navigating the current challenges of ever-increasing construction costs. The impact of the Camp Fire will be a key factor influencing the housing market in Oroville for many years, made even more

significant by the broader housing challenges experienced in California as a whole, and the impacts of the COVID-19 pandemic.

### ***North Complex Fire***

The North Complex Fire, the 6<sup>th</sup> largest and 5<sup>th</sup> most destructive wildfire in California history, burned 318,930 acres on the Plumas National Forest between August 2020 and October 2020. The fire tragically destroyed the town of Berry Creek and several rural communities near Oroville. The incident resulted in 16 deaths and damaged 2,455 structures (“*The Forgotten Fire?*” Ken Smith, Sacramento News & Review, October 2021). The impacts of the North Complex Fire on Oroville and surrounding communities are discussed further in Assessment of Fair Housing section of Chapter 4.

### ***COVID-19***

The COVID-19 pandemic and accompanying shutdown began in earnest in California in March 2020. This resulted in a statewide lockdown which closed many businesses in Oroville for nearly one year and forced those businesses which did remain open to implement different operational models. There were significant reductions in employment, especially for restaurants, retail and small businesses. While the lockdown was largely rescinded in July 2021, ongoing labor and supply shortages continue to impact the local economy. The pandemic also affected the usual community outreach and engagement strategies for the Housing Element update. The City implemented a menu of interactive virtual engagement opportunities, in recognition that the usual in-person outreach would not be possible. For example, in compliance with State and local public health orders, community meetings were moved to an online format, rather than in-person meetings. Meetings used polls and breakout rooms to engage the residents in conversation. The City developed a Housing Element website to serve as a central hub for residents to provide input via online surveys and learn about a variety of Housing Element topics. Efforts to adapt the process to ensure the participation of marginalized populations are fully described in the public participation process below. Despite these efforts, it must be acknowledged that some individuals who would usually participate in person at community meetings are not comfortable with an online format or may not have access to a computer or reliable internet and telephone services.

In terms of the housing market itself, what is known is that many of those who lost employment due to the pandemic found themselves doubling up with family and friends, or became homeless, even with rent relief measures that were enacted at the Federal level and the increase/extension of unemployment benefits. The pandemic’s economic pressures have exacerbated the need for affordable housing and a range of housing types to meet the needs of the community.

## REGULATORY FRAMEWORK

---

Since 1969, Housing Elements have been a required part of each local government’s General Plan process. The State has found that “Local and state governments have a responsibility to use the powers vested in them to facilitate the improvement and development of housing to make adequate provision for the housing needs of all economic segments of the community.” California Government Code Sections 65580-65589 codify the requirements for the content of, and process to develop the local Housing Element. The State Department of Housing and Community Development (HCD) is charged with reviewing and approving each jurisdiction’s Housing Element for compliance with State law.

California State law mandates that all localities adopt a Housing Element Update every eight years. The law also requires that Housing Elements address the following issues, among others:

- Include all economic segments of the community in the planning process;
- Review the progress and effectiveness of previous Housing Elements;
- Assess housing needs, including those of special needs populations, such as seniors, individuals experiencing homelessness, female-headed households, large households, and persons with disabilities;
- Assess the fair housing issues and trends in four key areas, contributing factors to these issues and trends, as well as the local jurisdiction’s fair housing enforcement and capacity;
- List units at risk of conversion from restricted rents to market rents;
- Inventory whether there are an adequate number of appropriately zoned sites to accommodate growth for all income groups, as projected by the State Department of Housing and Community Development;
- Describe available financial and energy efficiency resources;
- Address constraints to housing production; and
- Outline a housing program with goals, policies, and programs that are consistent with the General Plan and that address housing needs, constraints, and available resources, including any fair housing issues that have been identified. The housing program must include a timeline of programs during the planning period.

Since Oroville’s Housing Element was last adopted in 2014, the State Legislature has passed a significant number of laws which mandate new analyses or programs in each Housing Element, as well as an entire slate of laws regarding Accessory Dwelling Units (ADUs). These new laws apply to the 2022-2030 City of Oroville Housing Element update, and wherever available, HCD guidance memos have been followed in its development. These include, but are not limited to:

- ADUs (AB 3182, AB 671, AB 68, AB 587, AB 670, AB 881, SB 13)—These new laws limit local jurisdictions’ ability to restrict the development of ADUs in a variety of ways and mandate streamlined, ministerial approval of ADUs within defined conditions. For the purpose of the Housing Element, they clarify that a local agency may identify an ADU or

JADU as an adequate site to satisfy RHNA housing needs. AB 671 specifically requires that Housing Elements include a plan to incentivize and promote the creation of ADUs that can offer affordable rents for very-low, low-, or moderate-income households.

- **Affirmatively Furthering Fair Housing (AB 686)**—All Housing Elements adopted on or after January 1, 2021 must contain an Assessment of Fair Housing (AFH) conducted in accordance with HCD program guidance, and must include a program of actions that promote and affirmatively further fair housing opportunities throughout the community.
- **No Net Loss (SB 166)**— As jurisdictions make decisions regarding zoning and land use, and as development occurs, jurisdictions must have a program to assess their ability to accommodate new housing on the remaining sites in their Housing Element site inventories. A jurisdiction must add adequate sites if land use decisions or development results in a shortfall of sufficient sites to accommodate its remaining housing need for each income category.
- **Site Inventory (SB 6, AB 1397, AB 1486, AB 686, AB 725)**—The Housing Element establishes a jurisdiction’s strategy to plan for and facilitate the development of housing over the planning period by providing an inventory of land adequately zoned or planned to be zoned for housing and programs to implement the strategy. These laws modified the content of the site inventory, including new analyses for capacity calculations, infrastructure requirements, suitability of non-vacant sites, size of site and density requirements, location requirements, sites identified in the previous Housing Element and rezone program requirements, among others.

## **PUBLIC PARTICIPATION PROCESS**

Broad public participation is an essential component of the Housing Element update process, and is required by State law (Government Code Section 65583(c)(8)). Community outreach must be conducted through a variety of mechanisms to include all economic and cultural segments of the community. This has been furthered strengthened and expanded through the passage of AB 686 which mandates meaningful, frequent, and ongoing community participation, consultation, and coordination that is integrated with the broader stakeholder outreach and community participation process for the overall Housing Element.

The Oroville Housing Element update process for 2022-2030 employed an extensive outreach effort to engage a wide spectrum of the community within the necessary restrictions imposed by COVID-19. This effort included a Housing Element website, a comprehensive contact list, utilization of a variety of methods to disseminate information and engage residents in the process, an outreach event at the annual Salmon festival, two online community workshops and two online surveys.

After the draft document was completed, it was posted on the City's Housing Element webpage, with notice to the public as to its availability, and scheduled for review and comment at public hearings with the Oroville Planning Commission on June 23, 2022 and City Council on July 19, 2022. The public was provided with a 30-day public comment period from June 19 to July 19 before it was submitted to State HCD for review.

### *Outreach*

At the beginning of the Housing Element update process, a community outreach contact list was developed to email announcements about public meetings and progress and was updated throughout the process. This contact list included over 150 individuals and encompassed representatives from the following interests and organizations:

- City and County elected officials
- City of Oroville staff
- Butte Countywide Homeless Continuum of Care
- Butte-Glenn 211 (information and resource referrals)
- Far Northern Regional Center
- Northern Circle Indian Housing Authority
- Ethnic and cultural groups such as the Hispanic Resource Council of Northern California, North State Hispanic Chamber of Commerce, African American Family & Cultural Center and the Hmong Cultural Association
- Housing Authority of the County of Butte
- Affordable housing developers
- Water, transportation, and recreation organizations
- Disability rights advocates
- Legal services
- Senior services and advocacy groups
- Domestic violence and rape crisis services
- Education representatives
- Real estate brokers
- Property management association
- Chamber of Commerce and local businesses
- Healthcare organizations
- Civic organizations, such as the League of Women Voters
- Various non-profit organizations, including homelessness services
- Neighborhood associations
- Building industry representatives
- General interested community members

### *Methods for Information Dissemination and Engagement*

- **Website:** A website dedicated to the Housing Element update process was made available in three languages: English, Spanish and Hmong (toggle option at the top of the page); this webpage functioned as the central location for all information related to the Housing Element update. It included background information on the purpose of the Housing Element, how to participate, the update timeline, resources, and an

opportunity to sign up for an email list to receive direct emails on the update process. Most of the resources, including the presentation slides and recordings from the community meetings, are provided in both English and Spanish. Website address: [www. Orovillehousingelement.com](http://www Orovillehousingelement.com)

- **Social media:** The City’s Facebook and Instagram pages were used to notify residents of opportunities to participate in events such as community meetings and online surveys, as well as notifying them when new resources were posted to the website. Facebook events were created for the community meetings. Posts were made available in English, Spanish and Hmong.
- **Direct email:** Parallel to the Facebook and Instagram posts, all stakeholders and interested community members who signed up for email notifications received periodic “email blasts” throughout the process.
- **Flyers:** A trilingual (English/Spanish/Hmong) flyer announcing Community Meeting #1 was distributed to visitors at the Salmon Festival, a large community event. Flyers provided information on the options to join the meeting online or by calling in via phone, so residents with various levels of access to technology could participate
- **Newspaper articles:** The City sent public services announcements (PSAs) to local newspapers (Mercury Register and the Chico Enterprise Record) and news stations regarding the community meetings. These brief articles gave the public notice about their opportunity to participate in the meetings, with the meeting details.

### *Salmon Festival Outreach Event (focus group)*

Due to the COVID-19 pandemic, which limited in-person gatherings due to safety and disease control/prevention, the City was not able to hold a conventional focus group for low-income residents. Instead, the City held an outdoor community outreach event at the Salmon Festival in an effort to abide by the guidelines set forth by the Centers for Disease Control and Prevention. The Salmon Festival, which was held 10:00 – 4:00 pm on September 25, 2021, in Historic Downtown Oroville, is a well-attended, outdoor annual community festival that celebrates the migration of salmon up the Feather River in Oroville and brings together diverse members of the community.

The City set up a booth at the festival, conducting in-person outreach in an effort to encourage the participation of historically underrepresented community members in the Housing Element Update process. This included educating residents about the Housing Element Update process, answering questions, collecting feedback through paper and electronic surveys, and informing residents of upcoming community meetings. The materials were provided in English, Spanish, and Hmong.

The event and surveys provided residents with the opportunity to provide input on their housing needs and options as well as discuss any barriers or discrimination they faced in accessing housing. They also recommended housing types that are in the greatest need and ways to help people with limited means get into housing. Participants included residents

from a variety of demographic, racial, and economic backgrounds, including low-income residents, residents with disabilities, residents experiencing homelessness, seniors, and single mothers.

Below are key takeaways from residents:

- Many residents were unaware or uninformed of the Housing Element Update process or ways to meaningfully participate.
- The 2018 Camp Fire made it even more challenging to find an available affordable housing unit in the City and many individuals were unhoused.
- Residents could benefit from case management services to secure safe and decent housing and/or navigate housing discrimination.
- Special populations, especially people with disabilities, could benefit from a housing navigation center model and staff or peer-support at the center for help with accessing resources and navigating systems.

### ***Community Workshops and Online Surveys***

Community workshops were held on October 20 and November 17, 2021. These meetings were held on the virtual meeting Zoom platform due to COVID-19. The purpose of the workshops was to solicit input on housing needs, review previous Housing Element Goals, Policies and Programs, and recommend new actions to address unmet needs. Both the community meetings and surveys were advertised on the Housing Element website, the City’s Facebook, and Instagram pages, and in newspaper PSAs. These resources were promoted in English, Spanish, and Hmong. Each meeting included a presentation using PowerPoint slides, which were made available in English, Spanish, and Hmong and included definitions of commonly used terms in the Housing Element. Live Spanish interpretation was provided as option for participants during both meetings and Live Hmong interpretation was provided as an option for the second community meeting, as well as closed captions (Zoom “live transcript”) for those who are deaf, hard of hearing, or preferred a visual transcript of the meeting conversation. Interactive polls and a question and answer (Q&A) session helped make the meetings interactive and informative for participants.

Workshop #1 opened with a presentation on the background of the Housing Element process and its purpose; previous Housing Element progress; an overview of the housing needs, funding available to address those needs, and economic context; and an introduction to the previous Housing Element’s Goals, Policies and Programs. In the breakout group, participants then discussed the types of housing most needed in Oroville; what challenges are encountered in finding affordable housing; the special need for large household housing for low-income families and disability accommodations for residents with disabilities; fair housing; the role of ADUs in addressing unmet needs, overall constraints to the development of housing, SROs and why they haven’t been built, impacts from the Camp Fire, and to what degree home ownership should be a priority.

Workshop #2 opened with a presentation on the key findings from the Needs Assessment and an overview of the current Housing Element Goals, Policies, and Programs. In the breakout group, participants then discussed: Fair Housing, Patterns of Segregation, Home Ownership, Special Needs Housing, Promoting a Wide Range of Housing Types, Rehabilitation of Existing Neighborhood and Housing, After-effects of the Camp Fire, Energy Conservation and Affordable Housing. Resources from Workshop#1 and #2 can be found here: <https://www Orovillehousingelement.com/community-surveys>

Two online surveys, utilizing the SurveyMonkey platform, were available for community members to participate in. The surveys were advertised on the Housing Element Update website, social media, direct email, flyers, newspapers, and at both community meetings and the focus group. The first survey was open from September 25, 2021 to October 22, 2021, and the second survey was open from December 20, 2021 to January 3, 2022. The surveys were provided in English, Spanish, and Hmong. The first survey consisted of 16 questions which asked residents about:

- Their demographics
- The type of housing they live in
- Whether they rent or own their home
- If they were satisfied with their housing
- The physical condition of their home
- Challenges they have experienced in finding housing to meet their needs, especially affordability
- Barriers to home ownership
- The types of housing most needed in Oroville
- Discrimination they have encountered in searching for and securing housing
- Accommodations they or a family member need for a disabling condition and their ability to obtain those accommodations
- Their prioritization of the City's current Housing Element Goals

The second survey consisted of 7 questions which addressed the following topics:

- Their demographics
- Their ability to secure safe and decent housing in Oroville
- The types of housing they would like to live in
- Impacts of the Camp Fire on housing displacement
- Potential actions to promote a mix of dwelling types and sizes
- How to incentivize the construction of ADUs that offer affordable rents to lower-income households

A total of 65 responses were collected from both surveys. Survey participants represented a diverse set of backgrounds, including college students, seniors, single mothers, low-income

residents, local government officials, and both renters and owners. In the first survey, most residents wanted to live in a detached, single-family homes and over half of participant's residences needed repair, ranging from minor to major improvements. Over 60% of residents felt that the range of housing options in the City did not meet their needs, with the majority of participants citing that there is an insufficient amount of affordable housing and housing options, including housing for seniors and people with disabilities, affordable rental units, and permanent, supportive housing. The survey indicated that 70% of participants felt that there is a need for affordable apartments, 50% felt that there is a need for housing close to services, 60% felt there is a need for single-family homes, and 45% indicated that there is a need for special needs housing in Oroville. About 60-70% of participants reported that residents could benefit from information on assistance programs, down payment assistance, and loans or assistance for repairs and rehabilitation. Many participants cited a recent increase in homelessness.

Participants in the second survey also represented a diverse set of backgrounds. About 60% of participants had trouble purchasing a home due to increases in home prices following the Camp Fire. About 25% of participants reported that increasing partnerships between local governments and agencies, promoting affordable development in the City center, prioritizing development in areas of high segregation and poverty, and decreasing impact fees for affordable housing development are actions that should be given the highest priority. Most participants indicated that offering pre-approved building plans and providing funding for construction costs or forgivable loan programs would be beneficial in promoting the construction of Accessory Dwelling Units.

Summary reports of both community surveys can be found at this link:

<https://www.orovalhoousingelement.com/community-surveys>

### ***Community Input Summary***

In evaluating the input received through these varied engagement efforts, a number of consistent themes were expressed by community members. They are summarized here with a description of how they are being addressed through the Housing Element programs noted in Chapter 3:

- The Camp Fire had a significant impact on housing displacement and choice because many Camp Fire survivors relocated to Oroville. Given the ongoing risk posed by wildfire in communities surrounding Oroville, as demonstrated by the North Complex Fire in 2020 and the Dixie Fire in 2021, intergovernmental and interorganizational collaboration on housing issues in Butte County is needed.

*This input is to be addressed through:*

*Goal 1, Program 1.2.1 “Continue to work with the Butte County Homeless Continuum of Care Coalition to facilitate the provision of shelter and services for individuals experiencing homelessness, with the goal of rapidly re-housing individuals.”*

*Goal 1, Program 1.2.4: “The City will work to provide technical assistance in grant funding applications for the development of new facilities to serve individuals experiencing homelessness as needed.”*

- There continues to be a significant shortage of affordable rental units which was exacerbated by the loss of naturally occurring affordable housing due to the Camp Fire. This limits the housing options for the lowest-income households, including seniors, persons with disabilities and those experiencing homelessness.

*This input is to be addressed through:*

*Goal 1, Program 1.2.2 “Amend the City’s Zoning Code to allow Low Barrier Navigation Center development as a use by right in areas zoned for mixed uses and nonresidential zones permitting multifamily uses if it meets specified requirements, as defined and delineated in AB 101.”*

*Goal 2, Program 2.1.5 “**Transitional Housing Code Amendments.** The City will add a provision to its Municipal Code that will allow Transitional Housing, as defined by Section 50675.2 of the Health and Safety Code, by-right in all residential zoning districts, with no additional requirements than what would be applied to any other residential use.”*

*Goal 2, Program 2.1.6 “**Supportive Housing Code Amendments.** The City will add a provision to its Municipal Code that will allow Supportive Housing, as defined by Section 50675.14 of the Health and Safety Code, by-right in all residential zoning districts, with no additional requirements than what would be applied to any other residential use.”*

- There are a substantial number of homes in Oroville that need repair, rehabilitation, and/or improvements, including ADA accessibility improvements.

*This input is to be addressed through:*

*Goal 4, Program 4.2.1 “The City will install and upgrade public service facilities (streets, curb, gutter, drainage, and utilities) to increase private market investment in declining, deteriorating, and infrastructure deficient neighborhoods.”*

*Goal 4, Program 4.3.1: “To the extent that funding is available, the City will purchase abandoned homes, and provide rehabilitation assistance to improve deteriorated neighborhoods. Rehabilitated homes will be sold to low-income residents.”*

*Goal 4, Program 4.3.2: “To the extent that funding is available, the City will support the rehabilitation of approximately 5 units over the next planning period.”*

- The City’s Municipal Zoning Code may be constraining housing development and/or hindering the development of new housing to meet the needs of all residents

*This input is to be addressed through:*

*Goal 2, Program 2.1.5: “The City will add a provision to its Municipal Code that will allow Agricultural Worker Housing for six or fewer persons by-right in all residential zoning districts, with no additional requirements than what would be applied to any other residential use “*

*Goal 2, Program 2.1.6: “The City will add a provision to its Municipal Code that will allow Transitional Housing, as defined by Section 50675.2 of the Health and Safety Code, by-right in all residential zoning districts, with no additional requirements than what would be applied to any other residential use.”*

*Goal 2, Program 2.1.7: “The City will add a provision to its Municipal Code that will allow Supportive Housing, as defined by Section 50675.14 of the Health and Safety Code, by-right in all residential zoning districts, with no additional requirements than what would be applied to any other residential use.”*

*Goal 2, Program 2.1.8: “Establish a comprehensive program to remove constraints to the production of Accessory Dwelling Units (ADUs) in accordance with State law.”*

*Goal 2, Program 2.1.9: “Amend the Municipal Code to revise emergency shelter parking requirements to comply with AB 139, to not require the number of parking spaces beyond what is necessary for staff that work at the shelter.”*

- Preserving and creating affordable housing options with services that complement housing are a high priority.

*This input is to be addressed through:*

*Goal 6, Program 6.1.3: “The City will meet with Community Housing Improvement Program (CHIP) and Butte Habitat for Humanity (Habitat) once per year to discuss potential development opportunities in the City and methods for collaboration “*

*Goal 6, Program 6.4.3: “Meet with Disability Action Center, Butte County, and Legal Services of Northern California (LSNC) at least once per year to coordinate information, referrals, and outreach to residents.”*

### ***Affirmatively Furthering Fair Housing: Accessibility and Language***

As described in the sections above, the City designed and implemented public outreach in accordance with AB 686, Affirmatively Furthering Fair Housing. This section describes these efforts in greater detail.

- **Accessibility:** The first survey was made available online and in paper copy, with the second survey made available online. Both surveys were provided in English, Spanish, and Hmong for three to four weeks so residents could access it in their preferred format, language, day of the week, and time of the day. The Focus Group and Community Workshops were held mid-week in the evenings to minimize barriers to participation based on work hours. Due to COVID-19, they were held virtually using Zoom. This minimized barriers to participation related to transportation and childcare. Flyers advertised both online and call-in methods for joining the meeting so barriers related to access to technology would be minimized. Challenges encountered included designing virtual meetings to be as similar as possible to in-person meetings, and some residents who would usually participate in person at community meetings not being comfortable with an online format or not having access to a computer or reliable internet and telephone services.
- **Language:** As of 2019, 84.5% of Oroville residents over the age of five speak English, 5.6% Spanish, and 6.6% Asian and Pacific Islander languages at home (*U.S. Census 2015-2019 American Community Survey*). Thus, the City focused its efforts on robust trilingual materials and interpretation for English, Spanish, and Hmong languages and contracted with a professional translator for services. In addition, Zoom’s “live transcript” closed captions feature was used for the Focus Group and Community Workshops so residents who are deaf or hard of hearing or who prefer to read closed captions were able to access information. Technical support instructions were provided at the beginning of the workshops to orient residents to the accessibility and language features. Recordings of the Community Workshops in English, Spanish, and Hmong were posted on YouTube with closed captions and linked to the Housing Element website. Bilingual presentation slides, breakout group notes, and bilingual definitions of frequently used terms are linked on the Housing Element website: <https://www.orovillehousingelement.com/resources>

## INTERGOVERNMENTAL REVIEW PROCESS

---

As required in Government Code Section 65589.7, the City has provided its water and sewer providers with an opportunity to participate in the Housing Element so that housing production can be coordinated with infrastructure plans. The City of Oroville has several utility providers, which are Thermalito Water and Sewer (TWSD), South Feather Water and Power, Lake Oroville Area Public Utilities District (LOPUD) California Service Company (CAL Water), and Sewage Commission- Oroville Region (SCOR). At the outset of the Housing Element planning process, the City sent letters to all providers. The letters requested confirmation that the provider has written policies and procedures granting priority for the provision of their services to proposed developments that include low-income housing (per SB 1087, adopted in 2005). The letters also requested that providers review the Housing Element draft, and a keep a copy of the final Housing Element on file. Following adoption of the Housing Element, the City will continue to work with water and sewer providers to coordinate housing and infrastructure plans.

## CHAPTER 2: REVIEW OF PREVIOUS HOUSING ELEMENT

### BACKGROUND

---

The Oroville City Council adopted the most recent Housing Element in June 2014 for the planning period of 2014-2022. The City's 2014 Housing Element was adopted during a time of significantly reduced funding, compared to the 2009 Housing Element. In 2012 the State of California had eliminated Redevelopment Agencies (RDA), and along with them, the City's primary source of affordable housing funding, the Redevelopment Agency Housing Set Aside. Due to the loss of the RDA funding, along with ongoing cuts to both CDBG and HOME at the federal level, the City's funding sources decreased significantly. Though there were cuts due to the dissolution of the RDA, the Housing Department was successful in the applying for CDBG and HOME funding to maintain these programs.

Key initiatives included:

- Provide homebuyer and first-time homebuyer assistance up to \$100,000 or 45% of the purchase price of the home; whichever is less (Action 1.1.1)
- Ensure the City's policies and codes promote fair housing and equal access by amending the City's reasonable accommodation procedure for persons with disabilities (Action 1.3.1)
- A number of actions to protect existing neighborhoods from deterioration and encroachment, including augmenting code enforcement activities to supplement the graffiti removal program, fund neighborhood clean-up fairs, and code enforcement and community beautification efforts (Action 4.1.1); Install and upgrade public facilities such as streets, curb, gutter, and utilities to encourage private market investment in neighborhoods in need of revitalization (Action 4.2.1) purchase abandoned homes, and provide rehabilitation assistance to improve deteriorated neighborhoods (Action 4.3.1); Fund the rehabilitation of owner occupied single family homes (Action 4.3.2)
- Promote the development of affordable housing through a diverse set of strategies, including maintaining and publicizing a list of housing developments that serve lower-income households, persons with disabilities, or other special needs households (Action 1.2.3); Provide technical assistance to developers, nonprofits, or other private sector interests in seeking federal and state financing for affordable housing (Action 3.2.1)

### STATE REQUIREMENTS

---

State Housing Element law (Government Code Section 65588) requires that Housing Elements review the previous Housing Element in the following ways:

- Progress in implementation, including a description of the actual results or outcomes of previous Housing Element goals, policies, and actions.
- Effectiveness, including a comparison of what was projected or planned in the previous Housing Element and what was actually achieved.
- A description of how past programs were effective in addressing the housing needs of special populations, including seniors, farmworkers, those with disabilities and people experiencing homelessness.
- Appropriateness of goals, policies and actions, including a description of what has been learned based on the analysis of progress and effectiveness of the previous Housing Element, and how the Housing Program is being changed or adjusted to incorporate what has been learned from the results of the previous Housing Element.

This chapter of the Housing Element addresses these requirements as follows:

- Progress in Implementation: **Appendix A** provides a detailed assessment of the accomplishments and effectiveness of each 2014 Housing Element Action. It also includes notes indicating whether the Action is proposed to be deleted, continued or modified.
- Effectiveness: The subsections on **Housing Production Goals and Results** and **Results of Previous Housing Element Actions** compare what was projected or planned to what was actually achieved. Information on whether Actions are proposed to be deleted, continued or modified is also summarized here.
- Addressing Housing Needs of Special Populations: The subsection on **Results of Previous Housing Element Actions** analyzes how past actions were effective in addressing the housing needs of special populations.
- Appropriateness of goals, policies and actions: The subsection on **Implication of Findings for the 2022 Housing Element** addresses what has been learned through the analysis of the previous Housing Element's effectiveness and progress, and what is being changed or adjusted in the 2022 Housing Element based on this information.

## **HOUSING PRODUCTION GOALS AND RESULTS**

---

State law requires regions to plan for housing needs based on future growth projections through the Regional Housing Needs Allocation (RHNA), per Government Code Section 65584. The State Department of Housing and Community Development allocates numeric RHNA unit production goals to regional councils of government, which then allocate these goals to each community within its area of governance. For Butte County and each of its incorporated cities the regional council of government is the Butte County Association of Governments (BCAG). The RHNA goals identify the housing units needed to accommodate growth over the planning period for each of

four different income levels: Very-Low (which includes Extremely-Low), Low-, Moderate- and Above-Moderate Income.

State law does not require that communities meet the RHNA production goals. Instead, State law requires that communities employ planning and funding mechanisms that enable them to achieve the goals. One mechanism that carries a specific State mandate is the Adequate Sites Inventory, described in Chapter 5, per Government Code Section 65583.2. This section requires that each community ensure that there is adequate appropriately zoned land within its jurisdiction to accommodate its RHNA. If a community did not comply with this requirement at the time of submission of the last Housing Element to the State, it must show how this was corrected in the next Housing Element planning period through re-zoning, annexation or other means. Oroville’s 2014 Housing Element Adequate Sites Inventory demonstrated that the City had sufficient vacant land appropriately zoned to provide for the RHNA.

*Figure 1* shows Oroville’s RHNA for the period of January 1, 2014 to June 30, 2022, and the number of units produced from 2014 through 2021 that are affordable to each income level.

**Figure 1: Regional Housing Needs Allocation and Production, January 2014-June 2022**

Income Level	RHNA Allocation	Units Produced	% of RHNA Produced
Extremely Low	209	0	0.0%
Very Low	210	0	0.0%
Low	284	205	72.2%
Moderate	306	0	0.0%
Above-Moderate	784	250	31.9%
<b>Total</b>	<b>1,793</b>	<b>674</b>	<b>37.6%</b>

*Sources: Butte County Association of Governments, 2014 Regional Housing Needs Plan, City of Oroville Community Development Department, 2021*

In addition to the production of new affordable units, the City assisted 164 households through its Homebuyer Downpayment Assistance Program through January 2022 and 3 households through its Owner Occupied Housing Rehabilitation Program through January 2022.

## RESULTS OF PREVIOUS HOUSING ELEMENT ACTIONS

---

The 2014 Housing Element included a Housing Program of six Goals. Within each Goal was a set of Policies and Actions. Below is a summary of the Goals and the number of Actions associated with each.

- 1: Increase housing opportunities and accessibility (6 Actions)
- 2: Remove constraints to housing (3 Actions)
- 3: Promote construction of a wide range of housing types (3 Actions)
- 4: Improve, rehabilitate, and revitalize existing neighborhoods (6 Actions)
- 5: Promote Fair Housing (2 Actions)
- 6: Encourage energy efficiency in housing (2 Actions)

The City's progress on these Goals and Actions is summarized below within the categories of

- One Time Actions Completed
- Ongoing Actions That Made Progress
- Actions That Did Not Make Progress
- Effectiveness of Actions to Address The Needs of Special Populations

### *One Time Actions Completed*

**Update City zoning regulations for Emergency Shelters, Transitional and Supportive Housing, and SROs to be consistent with state law—Action 1.2.2:** As a part of Ordinance 1804, the City Council amended zoning codes for emergency shelters, transitional and supportive housing, and SROs to ensure consistency with the State Law in 2014. **Action 1.4.1:** As a part of Ordinance No. 1804, the City amended local zoning, development standards, and permit processing to be in compliance with Health and Safety Code Section 65583. However, further amendments to the City Municipal Code are necessary to ensure compliance with all parts of Section 65583, as described in the Chapter 6 Constraints Analysis.

**Track Housing Element implementation progress—Action 2.1.2:** The City’s Housing Element is in compliance; the City has submitted its Annual Progress Report to the Department of Housing and Community Development.

**Ensure availability of adequate sites to accommodate RHNA—Action 3.1.2:** In 2015, the City updated zoning codes and maps to coincide with the General Plan land use designations. The City’s MXC and MXN mixed-use zones now permit multi-family, high-density residential development.

**Mandate compliance with Title 24 of the California Administrative Code—Action 6.1.1:** The Building Department updated zoning codes to require all new residential development to comply with energy conservation requirements set forth by Title 24 of the California Administrative code.

### *Ongoing Actions That Made Progress*

**Provide homebuyer assistance—Action 1.1.1:** The City applied for and was rewarded 2016 and 2018 HOME funds each in the amount of \$1,000,000 and CDBG Homeownership funds in the amount of \$1,000,000. The homebuyer assistance program has been so well-utilized by residents that these funds have been expended. The City also applied for and was awarded \$1,000,000 in 2019 HOME funds, \$1,000,000 in CDBG NOFA, and \$1,000,000 in 2020 CDBG funds to continue this program. Action 1.2.3: The City maintains an updated list of affordable housing projects on the City’s website.

**Monitor and improve the development review process—Action 2.1.1:** The City offers concurrent processing to streamline development and the zoning ordinance has been updated to provide incentives for low-income housing development, such as fast-track processing and density bonuses. The City has also developed a pre-application/development review process to help minimize processing times and increase information symmetry. In 2020, the City also developed a program to defer development impact fees by deed of trust until occupancy is issued.

**Periodically survey fees to ensure they are reasonably related to the cost of services provided—Action 2.1.3:** The master fee schedule was last updated in 2020 and is currently in the process of being updated for 2022. In addition, the City developed and instituted a fee deferral program for subdivisions of all income types.

**Regularly update the City’s GIS system—Action 3.1.1:** The City maintains a list of vacant lands that is shared with the public by request.

**Secure funding for the production of new affordable housing—Action 3.2.1:** The City secured federal and state financial assistance to produce 40 units through 2021. The City also

donated vacant land where 12 townhomes will be developed by Veteran Housing development corporation and is working on a 60-unit supportive housing project in the City that will be constructed in two phases.

**Secure grants to augment code enforcement and clean up neighborhoods—Action 4.1.1:**

The City applied for and received 2017 CDBG funds and CalOES funds to continue code enforcement activities. In addition, the City assembled a task force of law enforcement, code enforcement, and staff from Parks and Trees to identify code issues and housing complaints. The City has continued the City’s Code Enforcement efforts through increased staffing.

**Install and upgrade public infrastructure—Action 4.2.1:** The City is evaluating the condition, demands, and future needs of public facilities. The City developed a Capital Improvement program that will be implemented annually with roadway, sewer, and drainage infrastructure improvements to support infill development.

**Purchase Abandoned Homes and Provide Rehabilitation Assistance—Action 4.3.1:** The City does not have funding to provide rehabilitation assistance but is actively acquiring and reselling properties in default. The City acquired and paid off primary loans for several foreclosed homes in this reporting period. Some homes have been sold for fair market value while others were donated to VHDC to sell to income-qualified veterans. The City uses Housing Program Funds (previously RDA funds) and City Revolving loans funds to cure the defaults. The City was awarded PLHA funds to continue this activity.

**Support the Owner Occupied Single-family Rehabilitation Program—Action 4.3.2:** The City rehabilitated one home, and is currently seeking a contractor to oversee future rehabilitation projects. The City applied for and was awarded \$750,000 in 2020 CDBG Owner-occupied rehabilitation funds and have procured a contractor to oversee up to 10 projects over the next three (3) years.

**Promote Fair Housing—Action 5.1.1:** City staff attends fair housing training and has coordinated fair housing workshops and distributed fair housing informational flyers in public spaces.

**Publicize energy conservation incentives—Action 6.1.2:** In, 2016, the City approved the inclusion of properties within the City of Oroville for three different Property Assessed Clean Energy (PACE) programs. 1)Ygreene Works, 2) HERO, and 3) Open PACE.

***Actions That Did Not Make Progress***

**Provide Funding Assistance for Rehabilitation of Multi-family Units—Action 4.3.3:** Due to lack of funding, the City was unable to rehabilitate multi-family units.

**Preserve Existing Affordable Rental Housing Stock—Action 4.4.1:** Due to lack of funding, the City has been unable regularly coordinate with the California Housing Corporation to identify and preserve at-risk units. However, a review of at-risk units has been conducted for this Housing Element and will continue as described in the Chapter 3 Housing Program under Action 4.1.2.

### *Effectiveness of Actions to Address The Needs of Special Populations*

**Secure funding for low-income senior housing— Action 3.2.1:** The City was awarded HOME Funding for the development of the Sierra Heights Project for seniors. Phase I of the project is completed and provides 40 units for extremely-low-income seniors and Phase II is underway and is expected to be completed in September 2022.

**Inform residents of senior independent living facilities—Action 5.1.2:** The City works with the Housing Authority of the County of Butte, the Community Action Agency, and other special interest groups to provide senior housing informational materials to residents. The City also administered a survey to seniors to identify their unique housing needs.

**Secure funding for housing that serves small and Extremely Low Income households— Action 3.2.1:** The City worked with developers to fund 5 multifamily housing projects using Disaster Low Income Housing Tax Credits that provide 312 units for low income and extremely low-income tenants. Although this is not an SRO project, the demographics of the City of Oroville indicate that most low-income households consist of 1-2 occupants. Therefore, small households will benefit from the development of new, multi-family rental units.

**Secure funding for housing people experiencing homelessness— Action 3.2.1:** The City worked with developers to secure funding for a permanent supportive housing project by providing a loan in the amount of \$1,000,000 of Housing program funds. In addition, the City assisted a Veteran Permanent Supportive Housing Project by providing land donation and a loan in the amount of \$1,750,000 to developer. This project will begin construction in 2023, and offer occupancy in 2024. Lastly, the City donated 5 homes and 3 vacant lots to the Veterans Housing Development Corporation to sell to low-income and extremely low-income veterans. While this is not technically a project for people with disabilities, it contributes towards meeting the housing needs of people with physical disabilities or mental health conditions.

**Work with the Butte County Homeless Continuum of Care to reduce homelessness—Action 1.2.1:** A City Council member meets with the Butte Countywide Homeless Continuum of Care regularly throughout the year to further COC objectives.

**Amend the zoning code to allow reasonable accommodation without discretionary review for persons with disabilities—Action 1.3.1:** As a part of Ordinance No. 1804, the City created an administrative mechanism for a disabled person to file a request for reasonable accommodation to make specific housing available to one or more individuals.

The City also made progress in the development of Permanent Supportive Housing as follows:

- Base Camp Village is a 12-unit permanent supportive housing project for people experiencing homelessness with a mental illness diagnosis. The housing project opened in April 2020.
- Prospect View will be another newly constructed project which will offer 39 units of permanent supportive housing for people experiencing homelessness with a mental illness. Construction is slated to begin in 2022 with units available for occupancy in 2023.

A detailed assessment of the accomplishments and effectiveness of each 2014 Housing Element Action can be found in **Appendix A**, with notes indicating if the Action is proposed to be deleted, continued or modified.

## IMPLICATION OF FINDINGS FOR THE 2022 HOUSING ELEMENT

---

### *Analysis*

Given the environment of largely constrained resources between 2014 and 2021, the City made considerable progress on its 2014 Housing Element Programs. Of the 23 actions, only 3 made no progress. The reasons included limited resources (lack of adequate staffing and appropriate funding), the housing market, and high building costs.

When looking at the City's progress in meeting the 2014-2022 RHNA target goals, it is clear that the private market made significant progress towards meeting the housing needs of low-income residents. It is equally clear that the lack of available public subsidies significantly impeded progress on the development of units for very-low and low-income households.

The Actions in the 2014-2022 Housing Element that were constrained by lack of funding are now poised to take advantage of the myriad of new or augmented funding programs available from the State and Federal governments. As described earlier, much of this funding was received as a result of the Camp Fire (CDBG-DR-MHP and Disaster Tax Credits). In addition, the City applied for and received SB-2, LEAP, REAP and PLHA funds. This will significantly support the development of new affordable housing, including permanent supportive housing targeted to individuals with disabilities and those experiencing

homelessness, as well as strengthening the City’s planning efforts around housing and investing in the South Oroville neighborhood

The Actions in the City’s 2022-2030 Housing Program, as shown in Chapter 3, are reflective of taking advantage of these new or augmented funding opportunities in partnership with developers, undertaking changes to the Municipal Code to equitably integrate patterns of development, and addressing recent State laws to remove constraints to the development of housing and shelter services for people experiencing homelessness.

### *Process*

City staff conducted an initial review of the 2014 Housing Element Actions to document accomplishments, assess effectiveness and recommend whether the Action should be continued, modified or deleted in the 2022 Housing Element update. Following this review, the Actions were discussed at Community Workshop #2, and public input on their relevance and feasibility was obtained. Based upon both the City and community review:

- the completed Actions which were intended to be one-time efforts have been removed. In addition, some Actions which are no longer feasible due to a lack of funding or community resources to carry them out have been removed.
- some Actions have been revised to bring them up to date with the most recent State legislation or to more appropriately address community resources that are available to support their execution.
- some actions that still have relevance and/or were intended to be ongoing efforts remain the same as the previous Housing Element.
- new Actions that were identified through the Community Outreach efforts, Needs Assessment, Assessment of Fair Housing, Constraints Analysis and/or are required by new State legislation have been added.

All of the Actions are detailed in the Housing Program (Chapter 3) and those which are new or modified are summarized below.

### *New Actions*

- Goal 1, “Increase the availability of permanent housing for all community residents” includes new actions to provide technical assistance in grant funding applications for the development of new facilities to serve individuals experiencing homelessness and incentivize the production of Accessory Dwelling Units (ADUs) that can be offered at affordable rents to Low- to Moderate-Income households per AB 671.

- Goal 2, “Remove governmental constraints to the development of housing” adds new programs to amend the Oroville Municipal Code for compliance with AB 139 (parking standards for emergency shelters and by right zoning to address shelter capacity requirements), as well as AB 101, which allows Low Barrier Navigation Centers as a use “by right” in areas zoned for mixed-use and non-residential zones permitting multi-family uses, decreases parking requirements for emergency shelters, and includes a provision to allow transitional housing, supportive housing, and agricultural farmworker housing in all residential zoning districts. It also establishes a comprehensive program to remove constraints to the production of Accessory Dwelling Units (ADUs) in accordance with State laws AB 3182, AB 68, AB 881, SB 13, AB 687, AB 680 and AB 681.
- Goal 3, “Support and encourage the construction of new housing at a range of costs, types, and tenures and in quantities to meet the needs of all income groups, including the very low-, low- and moderate-income groups” includes actions to develop a community engagement program to help identify and meet the housing needs of residents.
- Goal 4, “Improve, rehabilitate and revitalize existing homes and neighborhoods” includes new actions to guide redevelopment efforts in neighborhoods that are in need of reinvestment.
- Goal 5, “Promote energy conservation in residential neighborhoods” includes a new goal to bring green energy to residents with a focus on reducing costs.
- Goal 6, “Improve fair housing choice and equitable access to opportunity.” The requirements of AB 686 (Affirmatively Furthering Fair Housing) have resulted in a new set of 8 new actions within this goal.

### *Modified Actions*

- Goal 3, Action 3.1.3 updates the existing annual workshops offered to the community by working with one of the region’s largest employers.
- Goal 6, Action 6.1.2 expands the existing flyers that the City provides to residents, by including information regarding new programs available to residents.

## CHAPTER 3: HOUSING PROGRAM

### BACKGROUND

---

This chapter describes a Housing Program comprised of a comprehensive set of goals, policies and programs designed to address the City of Oroville’s housing needs. These needs have been identified through the needs assessment, assessment of fair housing, constraints analysis, site inventory, and resource inventory. The terms “goals, policies and actions” are defined as follows for the purpose of the Housing Element:

- **Goals:** The goals are broad statements of the community’s vision and values for itself and are not time dependent. They indicate the direction the community wishes to move towards in providing healthy, safe, sustainable, and affordable housing for all residents.
- **Policies:** The policies are the commitments that the City is making to achieve the related goal or vision and a statement of its operational philosophy around housing.
- **Actions:** These are the specific actions or activities that will carry out the related policies and move the community towards its goals in a concrete and measurable way over time.

The Goals of the Housing Element and the number of Policies and Actions within each Goal are as follows:

**Goal 1:** Increase the availability of permanent housing for all community residents (3 Policies, 6 Actions)

**Goal 2:** Remove constraints that could hinder the development of housing (1 Policy, 8 Actions)

**Goal 3:** Provide housing that is affordable to low-income households (2 Policies, 3 Actions)

**Goal 4:** Promote construction of a wide range of housing types (2 Policies, 5 Actions)

**Goal 5:** Promote the conservation of energy in residential neighborhoods (1 Policy, 2 Actions)

**Goal 6:** Improve fair housing choice and equitable access to opportunity (4 Policies, 9 Actions)

Within each goal area, the information is organized as follows, per State requirements:

- Statement of the goal
- Statement of the policy(ies) to achieve the goal
- Description of the program which is directly related to the policy
- The party(ies) responsible for the program’s implementation. This will include specific City staff, as well as community partners where appropriate. The responsibility for

approving and directing all City actions rests with the City Council, which is then carried out by designated City staff.

- Potential financing or funding source(s). The availability of funding resources is not guaranteed and is subject to change. More or fewer resources may be available during the planning period. This will impact the feasibility of carrying out the programs stated.
- Timeframe for completion. These timeframes provide a reasonable expectation for starting and/or completing programs, given current staff resources and workloads. Like funding, these are subject to change due to circumstances beyond the control of the City.

## GOALS, POLICIES AND PROGRAMS

---

### *Expand Housing Opportunity and Accessibility*

This section addresses how the City of Oroville will concentrate and focus efforts and resources on increasing the availability of permanent housing for all residents of the community.

#### **Goal 1: Increase the availability of permanent housing for all community residents.**

**Policy 1.1:** Encourage home ownership.

**Program: 1.1.1 Homeownership Program.** The City will continue providing first-time homebuyer assistance of up to \$100,000 or 45% of the purchase price of the home; whichever is less. The maximum purchase price allowed is \$314,000 for each qualified household, with the goal of assisting five units per year. At least one unit will be in Census Tract 30.01 if deemed feasible.

**Responsible Party:** Business Assistance and Housing Development

**Financing:** CDBG and HOME grant funds and both HOME and CDBG Program Income

**Time Frame:** Annually fund the program, and assist five units per year (minimum of one unit in Census Tract 30.01, if deemed feasible).

**Policy 1.2:** Work cooperatively with other governmental entities and local organizations to facilitate the provision of shelter and services for individuals experiencing homelessness, with the goal of rapid re-housing services.

**Program: 1.2.1 Partnerships with Local Organizations.** The City will maintain a representative on the Council of the Butte Countywide Homeless Continuum of Care to facilitate the provision of shelter and services for individuals experiencing homelessness, with the goal of rapidly re-housing individuals. The City will maintain and publish information which assists residents in applying for rental assistance, Emergency Housing (Section 8) Vouchers, and utility assistance or connecting residents to shelter and supportive services.

**Responsible Party:** Business Assistance and Housing Development

**Financing:** Grant funds

**Time Frame:** Ongoing, Update website annually

**Program: 1.2.2 Low Barrier Navigation Centers.** Amend the City's Zoning Code to allow Low Barrier Navigation Center development as a use by right in areas zoned for mixed uses and nonresidential zones permitting multifamily uses if it meets specified requirements, as defined and delineated in AB 101.

**Responsible Party:** Planning Division, Planning Commission, and City Councils

**Financing:** General fund

**Time Frame:** Within 6 months of adoption of the 2022-2030 Housing Element

**Program: 1.2.3 Affordable Housing Projects Listing.** The City will maintain and publicize a comprehensive listing of housing developments that serve low-income households, persons with disabilities, and other special needs populations. This list can be accessed by the public from the City's website under the Services tab.

**Responsible Party:** Planning Division Business Assistance and Housing Development

**Financing:** General fund

**Time Frame:** Update annually or as projects are placed into service

**Program: 1.2.4 Technical Assistance Program.** The City will work to provide technical assistance to local homelessness services agencies in grant funding applications for the development of new facilities to serve individuals experiencing homelessness as needed.

**Responsible Party:** City Administrator and Building Department

**Financing:** General fund

**Time Frame:** The City will meet with local homelessness service providers annually to ascertain and plan for technical assistance needs.

**Program: 1.2.5 ADU Incentives/Affordable Rentals.**

Develop a formal program that offers incentives to property owners who develop ADUs that offer affordable rents for very-low, low-, or moderate-income households, with recorded regulatory restrictions on rents. Incentives in the form of reduced fees, exceptions to customary development requirements, pre-approved and no cost plans, expedited processing times, and funding sources to subsidize construction costs will be considered.

**Responsible Party:** Planning Division, Planning Commission, and City Councils

**Financing:** General fund

**Time Frame:** Within two years of adoption of the Housing Element

## REMOVE CONSTRAINTS TO HOUSING

---

This section address how the City will remove constraints that could hinder the provision of housing through zoning and land use policies.

**Goal 2: Remove constraints that could hinder the production of housing.**

**Policy 2.1:** Minimize constraints to the development of affordable housing through supportive codes, ordinances, policies, and guidelines.

**Program: 2.1.1 Development Process Review Program.** The City will ensure that the City's review and approval process for residential development, including multi-family housing

and housing affordable to low-to-moderate income households, is expeditious. The City provides pre-application and development review meetings to help minimize processing times. The City will complete an annual review as part of the City's Housing Element Annual Report to evaluate application processing times and conditions of approval to determine whether improvements could reduce processing times without jeopardizing other public policy objectives. If the City's review and approval processes are found to unreasonably constrain development, the City will take action to amend the process or establish guidelines and other mechanisms to promote increased application certainty and reduce processing time to the extent deemed feasible.

**Responsible Party:** Planning Division, Planning Commission, and City Council

**Financing:** General fund

**Time Frame:** Annually

**Program: 2.1.2 No Net Loss /Unit Production Evaluation Program.** Develop and implement a formal ongoing Unit Production Evaluation pursuant to Government Code section 65863 (No Net Loss law). The Unit Production Evaluation will be carried out annually to track the number of extremely low-, very-low, low-, moderate- and above moderate-income units constructed to calculate the remaining unmet RHNA and the sites available to meet the RHNA. It will also track the number of units built on the identified sites to determine the remaining site capacity by income category and maintain a database of all developable land within the City. If sites identified in the Housing Element to meet RHNA are developed with non-residential uses during the Housing Element planning period, the Unit Production Evaluation will include a plan to replace those sites, which may involve identification of new residentially zoned sites, rezoning of non-residential sites and/or annexation of new sites. The evaluation procedure will be updated annually and when sites identified in the Housing Element to meet RHNA are approved for development. The City will encourage the development of multi-family housing units in all zones by not requiring a conditional use permit.

**Responsible Party:** City Administrator and Contract Planner

**Financing:** General Fund

**Time Frame:** Within one year of adoption of the 2022-2030 Housing Element

**Program: 2.1.3 Development Impact Fee Review Program.** The City will continue to periodically survey the development application, plan check, and inspection fees, impact

fees, and utility connection fees of other cities in the Butte County region to ensure that these City fees are reasonably related to the cost of services provided.

**Responsible Party:** Planning Division, Finance Department, and City Council

**Financing:** General fund

**Time Frame:** Every 2 years, last updated in 2020

**Program: 2.1.4 Agricultural Worker Housing Code Amendments.** The City will add a provision to its Municipal Code that will allow Agricultural Worker Housing for six or fewer persons by-right in all residential zoning districts, with no additional requirements than what would be applied to any other residential use.

**Responsible Party:** Planning Division, Planning Commission, and City Councils

**Financing:** General fund

**Time Frame:** Within 6 months of adoption of the 2022-2030 Housing Element

**Program: 2.1.5 Transitional Housing Code Amendments.** The City will add a provision to its Municipal Code that will allow Transitional Housing, as defined by Section 50675.2 of the Health and Safety Code, by-right in all residential zoning districts, with no additional requirements than what would be applied to any other residential use.

**Responsible Party:** Planning Division, Planning Commission, and City Councils

**Financing:** General fund

**Time Frame:** Within 6 months of adoption of the 2022-2030 Housing Element

**Program: 2.1.6 Supportive Housing Code Amendments.** The City will add a provision to its Municipal Code that will allow Supportive Housing, as defined by Section 50675.14 of the Health and Safety Code, by-right in all residential zoning districts, with no additional requirements than what would be applied to any other residential use.

**Responsible Party:** Planning Division, Planning Commission, and City Councils

**Financing:** General fund

**Time Frame:** Within 6 months of adoption of the 2022-2030 Housing Element

**Program: 2.1.7 Accessory Dwelling Unit Code Amendments.** Establish a comprehensive program to remove constraints to the production of Accessory Dwelling Units (ADUs) in accordance with State laws AB 3182, AB 68, AB 881, SB 13, AB 687, AB 680 and AB 681, as delineated in HCD’s “Accessory Dwelling Handbook” (December 2020 and any subsequent updates This will require a thorough analysis of the City’s zoning code, planning processes and development standards, with subsequent amendments to bring the City into compliance with the stated laws.

**Responsible Party:** Planning Division, Planning Commission, and City Councils

**Financing:** General fund

**Time Frame:** Within 6 months of adoption of the 2022-2030 Housing Element

**Program: 2.1.8 Emergency Shelter Code Amendments.** Amend the Municipal Code to revise emergency shelter parking requirements to comply with AB 139, to not require the number of parking spaces beyond what is necessary for staff that work at the shelter.

**Responsible Party:** Planning Division, Planning Commission, and City Councils

**Financing:** General fund

**Time Frame:** Within 6 months of adoption of the 2022-2030 Housing Element

## **FACILITATE HOUSING PRODUCTION**

---

This section address how the City will facilitate the development of housing that meets the needs of the community. The City maintains a goal to facilitate the development of a range of housing that varies sufficiently in terms of cost, design, size, location, and tenure to meet the housing needs of all economic segments of the community at a level which can be supported by the utility, water and street infrastructure. Because the City does not build housing itself, the City will take actions to support and facilitate the development of housing through land use policies, zoning, incentives, and funding acquisition. Ultimately, housing development will be carried out by private, for-profit, and non-profit developers

**Goal 3: Support and encourage the construction of new housing at a range of costs, types, and tenures and in quantities to meet the needs of all income groups, including the very low-, low- and moderate-income groups.**

**Policy 3.1:** Ensure that the City's inventory of residentially-zoned land is sufficient to accommodate development for all housing types and income levels commensurate with growth needs and the Regional Housing Needs Allocation.

**Program: 3.1.1 Vacant Parcel List.** The City will continue to perform regular updates to the City's GIS system to track development and maintain an accurate list of vacant residential land in the City.

**Responsible Party:** Planning Division and Engineering Division

**Financing:** General fund

**Time Frame:** Update annually

**Program: 3.1.2 Community Engagement Program.** The City will coordinate an annual workshop with Oroville Hospital to identify the housing needs of employees and ensure that the City's land use plans support the development of housing suitable for the local workforce as part of the City's overall economic development program.

**Responsible Party:** Planning Division, Business Assistance and Housing Development

**Financing:** General fund

**Time Frame:** The City will engage Oroville Hospital on an annual basis to discuss needs, opportunities and resources. This will be completed within 1 year of adoption of the Housing Element.

**Policy 3.2:** Provide technical assistance to developers, nonprofit organizations, or other qualified private sector interests in seeking federal and state financing for affordable housing, including units affordable to extremely-low-income households and supportive housing for persons with developmental disabilities.

**Program: 3.2.1 Technical Assistance Program.** The City will actively work to identify sources of funding and provide technical assistance to interested developers in seeking

funding for the construction of new affordable multi-family housing including units for large family households, extremely low-income households, and persons with development disabilities. Funding to be pursued includes tax-exempt mortgage revenue bonds; HCD's Multifamily Housing Program; and low-income housing tax credits (LIHTC). The City shall also assist by providing letters of support for funding applications during the application process to increase the chances of a project receiving a funding award.

**Responsible Party:** Planning Division and Business Assistance and Housing Development

**Financing:** LIHTC, Tax Exempt Bonds, and HCD

**Time Frame:** The City will develop a list of affordable housing developers who have developed or have indicated an interest in developing in Oroville. On at least an annual basis, the City will monitor grant funding opportunities and notify developers of the availability of funding and technical assistance to be provided by the City, if interested.

## **PRESERVE, REHABILITATE, AND ENHANCE EXISTING HOUSING**

---

This section addresses how the City will initiate all reasonable efforts to preserve the quality of existing housing opportunities and to conserve as well as enhance the quality of existing dwelling units and residential neighborhoods.

### **Goal 4: Preserve, rehabilitate, and enhance existing housing and neighborhoods.**

**Policy 4.1:** Protect existing residential neighborhoods from deterioration and encroachment of incompatible or potentially disruptive land uses and/or activities.

**Program: 4.1.1 Code Enforcement.** The City will assemble a taskforce of law enforcement, code enforcement, and staff from Parks and Trees to identify code issues and housing complaints.

The taskforce will identify code enforcement grants to augment current code enforcement activities to supplement the graffiti removal program, to fund neighborhood clean-up fairs, and general code enforcement and community beautification efforts. Utilize neighborhood resources, including neighborhood groups (e.g., Neighborhood Watch) to supplement City code enforcement activities. Where possible, link code enforcement activities to available funding for improvements and correction of violations.

**Responsible Party:** Business Assistance and Housing Development and Community Development

**Financing:** CDBG and CalOES funds

**Time Frame:** Establish taskforce within one year of adoption of the Housing Element.

**Program: 4.1.2 At-Risk Unit Monitoring Program.** Support the preservation of affordability for at-risk units (currently the City does not have any qualifying properties). The City will annually assess the status of projects with project-based rental subsidy contracts that restrict rents to affordable levels to determine the contract expiration dates and communicate with property owners regarding their noticing requirements to tenants under Government Code Section 65863.10. For projects with contracts that will expire in the next 3 years, consult with the Housing Authority of Butte County and develop a proactive plan to preserve affordable rents at these properties, including initiation of discussion with owners and exploration of financial resources to extend contracts.

**Responsible Party:** Business Assistance and Housing Development

**Funding Source:** Housing Program Fund

**Timeframe:** Annually throughout the planning period

**Policy 4.2:** Ensure adequate public facilities to support housing development.

**Program: 4.2.1 Capital Improvement Program.** The City will install and upgrade public service facilities (streets, curb, gutter, drainage, and utilities) to increase private market investment in declining, deteriorating, and infrastructure deficient neighborhoods. The City will evaluate public facilities on condition, demands, and future needs. The Capital Improvement Program will prioritize areas for investment for annual roadway, sewer, and drainage infrastructure as deemed feasible. The City will prioritize areas of high segregation and poverty for investment, which include Census Tracts 25, 28, 30.01, 30.02, and 37.

**Responsible Party:** Business Assistance and Housing Development, Planning Division, Engineering Division, Planning Commission, City Council

**Financing:** General Fund, CDBG

**Time Frame:** The City will identify and fund a minimum of one project in a Census Tract with high segregation and poverty (Census Tracts 25, 28, 30.01, 30.02, and 37) by 2027.

**Policy 4.3:** Facilitate housing rehabilitation and stabilize existing neighborhoods, especially those with high foreclosure and vacancy rates.

**Program: 4.3.1 Low-Income Home Rehabilitation Program.** The City will apply for funding sources to continue this program. To the extent that funding is available, the City will purchase abandoned homes, and provide rehabilitation assistance to improve deteriorated neighborhoods. Rehabilitated homes will be sold to low-income residents. The City will focus redevelopment efforts in areas of high segregation and poverty, which include Census Tracts 25, 28, 30.02 and 37 and utilize the results of from the Study Oroville Blight study to guide redevelopment efforts.

**Responsible Party:** Planning Division, Building Division, Business Assistance and Housing Development

**Financing:** General Fund, Housing Program Fund, PLHA funds

**Time Frame:** Apply annually for appropriate available funding. Once funding is secured, provide rehabilitation services to a minimum of 8 homes by 2030.

**Program: 4.3.2 Owner-Occupied Single-Family Home Rehabilitation Assistance Program.** The City will apply for funding sources to continue this program. To the extent that funding is available, the City will support the rehabilitation of approximately 10 owner-occupied units over the next planning period. The City will focus redevelopment efforts in Census Tracts 25, 28, 30.02 and 37, which are areas of high segregation and poverty.

**Responsible Party:** Planning Division, Building Division, Business Assistance and Housing Development

**Financing:** CDBG, HOME

**Time Frame:** Apply annually for appropriate available funding. Once funding is secured provide rehabilitation services to a minimum of 10 owner-occupied units by 2030.

## ENCOURAGE RESIDENTIAL ENERGY CONSERVATION

---

The City of Oroville maintains a goal to encourage energy conservation in residential neighborhoods, which can reduce energy bills and enhance housing affordability. The use of available energy conservation measures and programs directly impacts residents' monthly housing costs by saving them money on their energy bills, increases comfort and safety, and contributes to the conservation of limited resources.

### Goal 5: Promote the conservation of energy in residential neighborhoods.

**Policy 5.1:** Encourage residential energy conservation through required compliance with current building codes and incentives for voluntary conservation efforts.

**Program: 5.1.1 Energy Conservation Outreach.** The City shall assist in publicizing utility incentives for energy conservation through flyers on the City's website. In 2016, the City approved the inclusion properties within the City of Oroville for three Property Assessed Clean Energy (PACE) programs, which are Green Works, HERO, and Open PACE. The City will create and update flyers that detail information on programs and their eligibility requirements.

**Responsible Party:** Planning Division, Business Assistance and Housing Development

**Financing:** General Fund

**Time Frame:** Update flyers by July 2023, and annually thereafter as needed

**Program: 5.1.2 Energy Savings.** The City will join the Butte County Community Choice Aggregation fund to incentivize the use of green energy for both residents and businesses. The City will take an active role in providing educational materials that discuss the benefits of this program.

**Responsible Party:** Planning Division, Business Assistance, and Housing Development

**Financing:** General Fund

**Time Frame:** The City will join the fund by July 2023 and develop promotional materials by December 2023

## AFFIRMATIVELY FURTHER FAIR HOUSING

---

With the passage of AB 686, state and local public agencies are required to affirmatively further fair housing through deliberate action to explicitly address, combat, and relieve disparities resulting from past and current patterns of segregation to foster more inclusive communities. Following the guidance from State HCD, the City of Oroville first analyzes patterns and trends of disparate housing needs and disproportionate access to opportunities through outreach efforts, the assessment of fair housing, and the site inventory. Then, the City identifies and prioritizes significant contributing factors to fair housing choice. Finally, the City establishes strategic policies, goals, and actions to affirmatively further fair housing based on the analysis of contributing factors (*California State Department of Housing and Community Development, Affirmatively Furthering Fair Housing, 2021*). This section includes the goal, policies, and actions which were informed by the four affirmatively furthering fair housing sections: outreach (pg.), assessment of fair housing (pg. ), site inventory (pg. ) and identification of contributing factors (pg. ).

### **Goal: 6: Improve fair housing choice and equitable access to opportunity.**

**Policy: 6.1:** Move toward more balanced and integrated living patterns by addressing concentrations of naturally occurring affordable housing, low-income households, poverty, and low access to opportunity in the City.

**Program 6.1.1:** Approximately 70% of households who experience 1 of 4 Housing Problems or 1 of 4 Severe Housing Problems in the City are renter households and that trend is increasing. The City will coordinate with the Department of Housing and Community Development to evaluate whether the City's Community Development Block Grant (CDBG) Housing Rehabilitation Program can be used for housing rehabilitation for renters as well as homeowners. City to prioritize future rehabilitation, community beautification, or other investment efforts in Census Tract 30.01, when deemed financially feasible. To the extent possible, City to focus other redevelopment efforts in Census Tracts 25, 28, 30.02 and 37

**Responsible Party:** Business Assistance and Housing Development

**Financing:** Allocation of staff time and cost of trilingual outreach (English, Spanish, and Hmong) materials through General Fund

**Timeframe:** At least three qualifying properties in Census Tract 30.01 to receive funding through the City's Housing Rehabilitation Program every year, starting in the 2<sup>nd</sup> year of the Housing Element cycle, provided a qualified pool of applicants.

**Program 6.1.2:** The City will encourage the development of affordable housing in high resource areas, such as Census Tracts 27 and 31. The City will develop a program of incentives, such as increases in the density bonus and flexibility in development standards in new growth areas.

**Responsible Party:** Community Development Department and Assistance and Housing Development

**Financing:** Allocation of staff time through General Fund

**Timeframe:** Staff will analyze the opportunities for affordable housing development in new growth areas and present their findings and recommendations to both the Planning Commission and City Council by December 2023. Any needed modifications to the Municipal Code will be completed by December 2024.

**Program 6.1.3:** The City will meet with Community Housing Improvement Program (CHIP) and Butte Habitat for Humanity (Habitat) once per year to discuss potential development opportunities in the City and methods for collaboration. The focus will be on feasibility of self-help housing that includes low-interest loan and down payment assistance programs and permanent supportive housing. Assist developers with affirmative outreach to people of color, including Spanish and Hmong language materials. Evaluate if the City's Community Development Block Grant (CDBG) Homebuyer Program can be used for down payment assistance.

**Responsible Party:** Community Development Department and Business Assistance and Housing Development

**Financing:** Allocation of staff time and cost of trilingual outreach materials through General Fund

**Timeframe:** 2<sup>nd</sup> year of the Housing Element cycle. CHIP and Habitat to be in development on at least two projects each or in collaboration by the end of the Housing Element cycle.

**Policy 6.2:** Meet the housing needs of protected classes, including persons with disabilities and tribal populations.

**Program: 6.2.1 Accessibility Improvements Fund.** An average of 20-30% of the population has a disability, which is significantly higher than other areas of Butte County. The City will strive to pool funding resources to provide accessibility improvements for sidewalks, public facilities and infrastructure, residences, and businesses if deemed feasible. Per the City's existing Municipal Code an individual with disability may file a request to the City for reasonable accommodation.

Responsible Party: Planning Division and Engineering Division

Financing: General fund

Time Frame: As part of its annual Capital Improvement planning, the City will evaluate if there are certain areas of the city that should be prioritized for public accessibility improvements and annually budget funds accordingly.

**Program 6.2.2:** The City will meet with the Northern Circle Indian Housing Authority (NCIHA) Tribal HDAP Task Force at least bi-annually to identify opportunities for collaboration, which may include facilitating partnerships with local agencies, identifying funding resources, pooling funding resources, identifying sites for development or redevelopment, and working to increase community awareness, education, and support for future affordable housing developments.

**Responsible Party:** Community Development Department and Business Assistance and Housing Development

**Financing:** General Fund

**Timeframe:** Bi-annually

**Policy FH-6.3:** Increase fair housing outreach and engagement and expand materials to meet the linguistic needs of the City's residents.

**Program 6.3.1:** The City will confer with the Southside Oroville Community Center, school districts, Butte County Office of Education, the Disability Action Center, Youth for Change, the Hmong Cultural Center, and/or other local agencies at least once per year to assess community needs and issues. Information can be collected informally or formally through meetings, surveys, at community events, or other methods of engaging with the

community. The information will be used to better understand the community's issues and inform future planning processes.

**Responsible Party:** Community Development Department and Business Assistance and Housing Development

**Financing:** Allocation of staff time and cost of trilingual outreach materials through General Fund

**Timeframe:** Coordinate information, referrals, and outreach by the end of the 1<sup>st</sup> year of the Housing Element cycle. The City will evaluate its outreach efforts at least once per year and adjust as necessary.

**Program 6.3.2:** The City will meet with Legal Services of Northern California, Southside Oroville Community Center, school districts, Butte County Office of Education, the Disability Action Center, and Housing Authority of the County of Butte at least once per year to coordinate information, referrals, resources, and outreach to residents for available services related to emergencies, employment, housing, assistance programs, and income. This may include providing direct case management services to residents, posting links on the City's website and Facebook page, and posting physical flyers at City Hall in English, Spanish, and Hmong. In addition, the City will identify a singular point-of-contact to provide fair housing information to residents and/or work to integrate housing services to better assist residents.

**Responsible Party:** Community Development Department and Business Assistance and Housing Development

**Financing:** Allocation of staff time and cost of trilingual outreach materials through General Fund

**Timeframe:** Coordinate information, referrals, and outreach by the end of the 1<sup>st</sup> year of the Housing Element cycle. The City will evaluate its outreach efforts at least once per year and adjust as necessary.

**Program 6.3.3:** The City will strive to engage residents in areas experiencing high levels of segregation and poverty (Census Tracts 25, 28, 30.01, 30.02 and 37) to serve on boards, committees, task forces, and other local government decision-making bodies.

**Responsible Party:** City Manager, Community Development Department

**Financing:** Allocation of staff time.

**Timeframe:** The City will develop an outreach strategy and application process within 18 months of adoption of the Housing Element.

**Program 6.3.4:** The City will work to provide educational information and outreach to residents that may be interested in constructing Accessory Dwelling Units (ADUs). This may include and creating a short, 1–3-page Development Checklist for ADUs. In addition, the City will provide resources and materials both on the City’s website and at City Hall in English, Spanish, and Hmong.

**Responsible Party:** Community Development Department and Business Assistance and Housing Development

**Financing:** General Fund

**Timeframe:** First year of Housing Element Cycle, update annually

## HOUSING PROGRAM CONSISTENCY WITH THE GENERAL PLAN

Government Code, Section 65583(a)(7) requires that the Housing Element identify the means by which the Housing Program, including its Goals, Policies and Actions, will be consistent with other General Plan Elements and community goals. Responsible parties within the City organization are listed for each action above. The Community Development Department, Planning Division, is responsible for creating, implementing, and tracking progress on the 2030 General Plan. The Business Assistance/Housing Development Department, is responsible for administering the City’s housing programs, including federal CDBG and HOME funds, and the RDA Housing Set Aside, currently Housing Program Fund, which holds loan repayments from the former RDA housing loan portfolio. The Planning and Housing staff closely collaborated on the Housing Element update to ensure consistency with the other General Plan Elements. The Goals, Policies and Actions in this Housing Element update support and compliment the Oroville 2030 General Plan Goals, Policies and Actions, specifically the Land Use, Downtown, Economic Development, and Parks, Public Facilities and Services Elements.

In addition to preparing planning documents, the Community Development Department and Business Assistance/Housing Development Department prepares annual General Plan and Housing Element progress reports and presents them to the City Council. Housing Element progress is also provided to the State Department of Housing and Community Development through the filing of the Annual Progress Report (APR) at that time. These annual reviews

provide opportunity for City staff, the City Council and the general public to review progress and consistency between the General Plan Elements.

**Quantified Objectives**

Based on the policies and actions outlined above, the following objectives in *Figure 2*, represent a reasonable expectation of the maximum number of housing units that will be produced, rehabilitated, and preserved during this Housing Element cycle. Rehabilitation refers to low-income, owner-occupied, single-family homes and renter-occupied, multi-family units that are the focus of rehabilitation activities. Preservation refers to affordable rental units at risk of losing affordability without City and/or developer intervention within this planning cycle.

**Figure 2: Quantified Objectives Table**

	Income Level					Total
	Extremely-Low	Very-Low	Low	Moderate	Above-Moderate	
New Construction	50	50	50	350	100	600
Preservation of Affordable Rental Units At Risk Due to Expiring Contracts	N/A	N/A	N/A	N/A	N/A	N/A
Rehabilitation	2	44	98	0	0	144
<b>Total</b>	52	94	148	350	100	744

## CHAPTER FOUR: HOUSING NEEDS ASSESSMENT

In order to determine the housing needs for the City of Oroville, a comprehensive assessment of demographic, economic, and housing market data was conducted. This provides a baseline for identifying the City’s greatest housing needs, and forms the development of Goals, Policies, and Actions. Data sources for this assessment included: the U.S. Census Bureau, Department Housing and Urban Development, and Department of Agriculture; the California Departments of Development Services, Economic Development, Education, Finance, and Housing and Community Development (HCD); and the Butte County Association of Governments, Sierra North Valley Realtors Multiple Listing Service, National Housing Preservation Database, and the City of Oroville.

The Housing Needs Assessment has been organized by topic into the following sections. In response to recent State Housing Element affirmative fair housing legislation, this update to the Housing Needs Assessment includes an Assessment of Fair Housing.

- Assessment of Fair Housing
- Demographics
- Employment
- Household Characteristics
- Housing Stock Characteristics
- Rental Market
- For Sale Market
- At-Risk Units
- Housing Affordability
- Extremely Low-Income Households
- Special Needs Households

### AFFIRMATIVELY FURTHERING FAIR HOUSING: ASSESSMENT OF FAIR HOUSING

The California Department of Housing and Community Development released a new guidance titled “Affirmatively Furthering Fair Housing” (AFFH) on April 23, 2021, to assist jurisdictions in meeting the requirements set forth by AB 686. AB 686 creates new requirements for all state and local agencies to ensure that their laws, programs, and activities affirmatively further fair housing and that they take no action inconsistent with this obligation.

The AFFH guidance establishes new processes and guidelines for public entities to improve existing and institute new programs and policies to increase affordable housing for all residents, regardless of race, religion, sex, marital status, ancestry, national origin, color, familial status,

disability, and all other protected characteristics. The City will take an active role in promoting inclusive communities, further housing choice, and address racial and economic disparities through goals, policies, and programs.

The purpose of the Assessment of Fair Housing is to analyze the elements and factors that cause, increase, contribute to, maintain, or perpetuate segregation, racially or ethnically concentrated areas of poverty, significant disparities in access to opportunity, and disproportionate housing needs. In addition, this analysis considers the City's role in conducting fair housing outreach and enforcement. This section of the Housing Element includes identification and analysis of patterns and trends, local data and knowledge, other relevant factors, and conclusions and summary of issues (*California State Department of Housing and Community Development, Affirmatively Furthering Fair Housing, 2021*).

The authors primarily use census tract and block group data in this analysis. Counties are subdivided into census tracts and each census tract is further subdivided into block groups. All census tracts and block groups are uniquely numbered with a numerical code. There are nine census tracts that encompass the City of Oroville and surrounding unincorporated areas. These census tracts are Census Tracts 25, 27, 28, 29, 30.01, 30.02, 31, 33, and 37. The City is further divided into block groups, but these block groups do not include a small portion of the south end of the City encompassed by Census Tract 32 and a small portion at the east end of the City encompassed by Census Tract 26.02.

The Assessment of Fair Housing considers patterns and trends over times, local data and knowledge, and other relevant factors for the following five subsections:

- A. Fair Housing Enforcement and Outreach
- B. Segregation and Integration
- C. Racially/Ethnically Concentrated Areas of Poverty
- D. Disparities in Access to Opportunity
- E. Disproportionate Housing Needs and Displacement Risk

The authors of this report created a Census Tract Map, depicted below, that identifies the census tracts discussed in this analysis. The map below depicts Census Tracts 25, 27, 28, 29, 30.01, 30.02, 31, 33, and 37, each outlined in red. Each census tract is color-coded and named by its numerical code. The City of Oroville's boundaries are outlined in black.

Figure 2.1: Census Tract Map

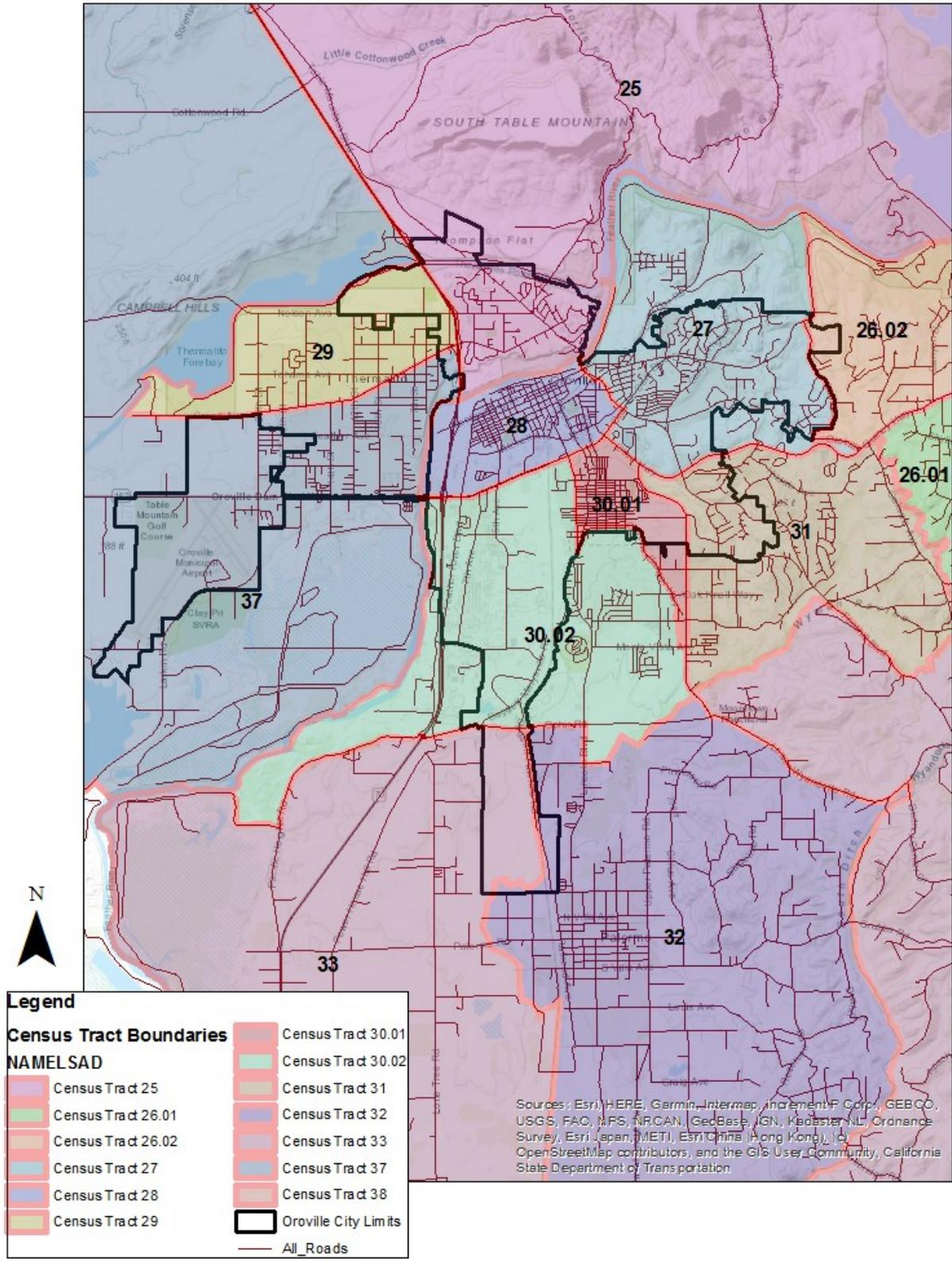

## A. FAIR HOUSING ENFORCEMENT AND OUTREACH CAPACITY

---

The first subsection of the Assessment of Fair Housing is an assessment of the jurisdiction’s fair housing enforcement and outreach capacity.

Pursuant to the California Fair Employment and Housing Act [Government Code Section 12921 (a)], the opportunity to seek, obtain, and hold housing cannot be determined by an individual’s “race, color, religion, sex, gender, gender identity, gender expression, sexual orientation, marital status, national origin, ancestry, familial status, source of income, disability, veteran or military status, genetic information, or any other basis prohibited by Section 51 of the Civil Code.”

### *Local and Regional Patterns and Trends*

This section includes data tables, narratives, and maps to illustrate local and regional patterns and trends regarding fair housing enforcement and outreach capacity. For the purposes of this analysis, fair housing enforcement and outreach includes the number of Housing Choice Vouchers, fair housing inquiries, and public housing buildings in the City. The Housing Choice Voucher Program provides rental assistance to very low-income families.

### *Housing Choice Vouchers*

The table “*City of Biggs, City of Gridley, City of Oroville, City of Chico, and Butte County, Number of Households with Housing Choice Vouchers, 2021*” depicts the number of households who hold Housing Choice Vouchers in Biggs, Oroville, Chico, Gridley, and Butte County in 2021. Housing Choice Vouchers provide financial assistance to allow very low-income families to choose and rent market-rate safe, decent, and affordable privately-owned rental housing (*U.S. Department of Housing and Urban Development, 2021*). The Housing Authority of the County of Butte provided 552 Housing Choice Vouchers (HCV) to residents in the City of Oroville. In comparison, 993 households hold vouchers in Chico, 48 households hold vouchers in the City of Gridley, and 6 households hold vouchers in the City of Biggs. There are 1,684 vouchers in use in Butte County in total.

The map “*City of Oroville, Housing Choice Vouchers, 2021*” depicts the percentage of renter-occupied housing units that hold Housing Choice Vouchers (HCV) within each Census Tract in the City of Oroville in 2021. Census Tract 28 has the highest concentrations of renter-occupied households that hold HCVs in the entire City at 15-30% of all HCVs. Census Tract 31 has the lowest concentration of renter occupied households that hold HCVs, ranging from 0-5%. HCVs are distributed evenly in the remaining census tracts at concentrations ranging from 5-15% of renter-occupied households.

The map, “*Butte County, Housing Choice Vouchers, 2021*” depicts Housing Choice Vouchers (HCVs) as a percentage of renter occupied housing units in Butte county. Much of the

unincorporated county does not have data available. Census tracts west of Magalia/Paradise and west of Gridley have 0-5% of renter occupied housing units as households with an HCV. Many of the census tracts surrounding Thermalito and Oroville have 5-15% of renter occupied housing units as households with an HCV. The city of Oroville is the only area in the county with 15-30% of renter occupied housing units as households with an HCV (*HCD AFFH Data Resources and Mapping Tool: U.S. Housing and Urban Development*).

**Figure 3: City of Biggs, City of Gridley, City of Oroville, City of Chico, and Butte County, Number of Households with Housing Choice Vouchers Table, 2021**

Jurisdiction	Number of Households with Housing Choice Vouchers
City of Biggs	6
City of Gridley	48
City of Oroville	552
City of Chico	993
Balance of County	85
<b>Butte County (Total)</b>	<b>1,684</b>

*Source: Housing Authority of the County of Butte, May and August 2021 Correspondence*

Figure 3.1: City of Oroville, Housing Choice Vouchers Map, 2021

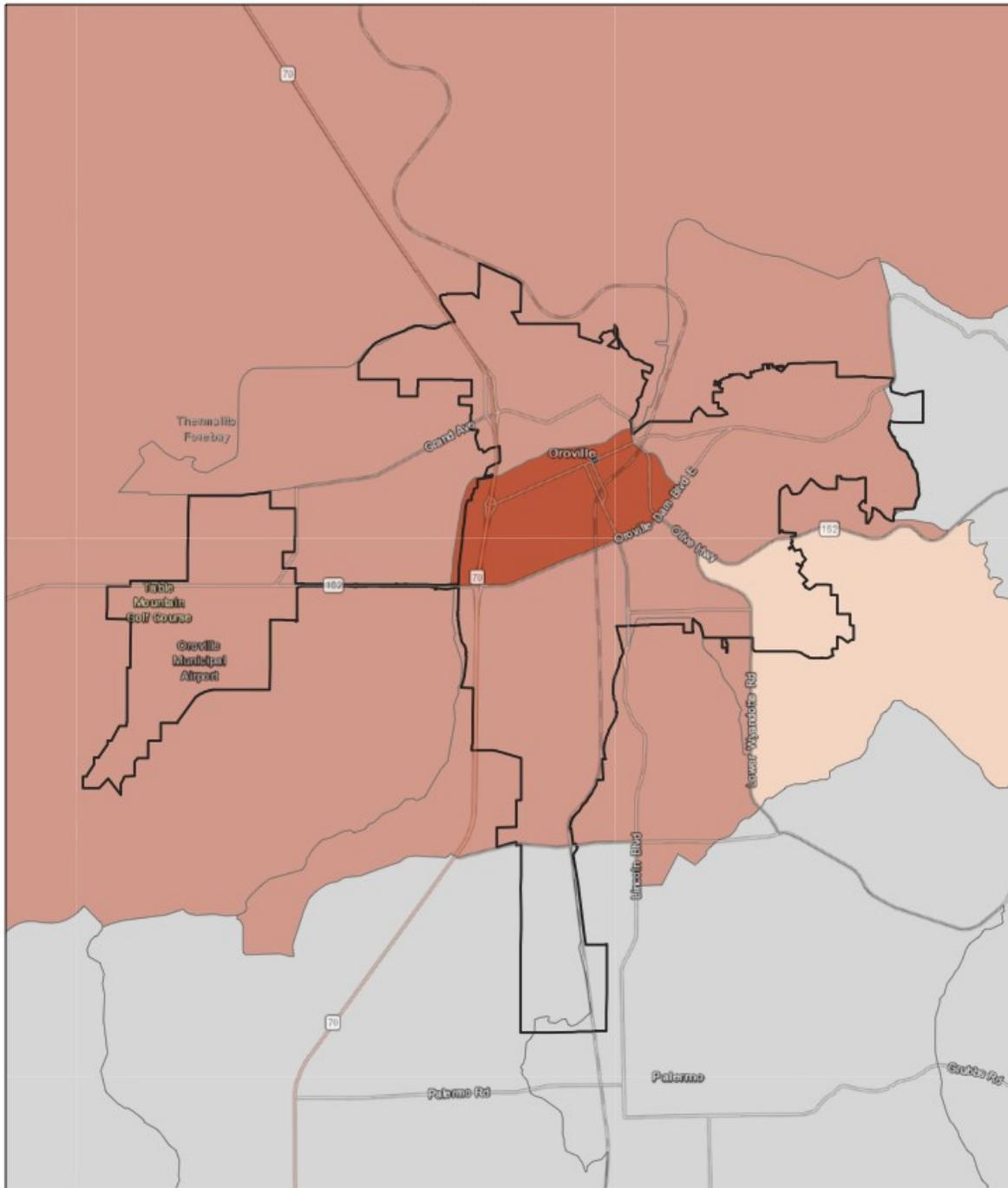

11/8/2021, 10:20:59 AM

City/Town Boundaries

(R) Housing Choice Vouchers - Tract

No Data

> 0 – 5%

> 5% – 15%

> 15% – 30%

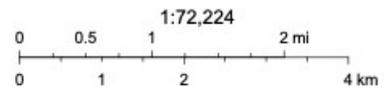
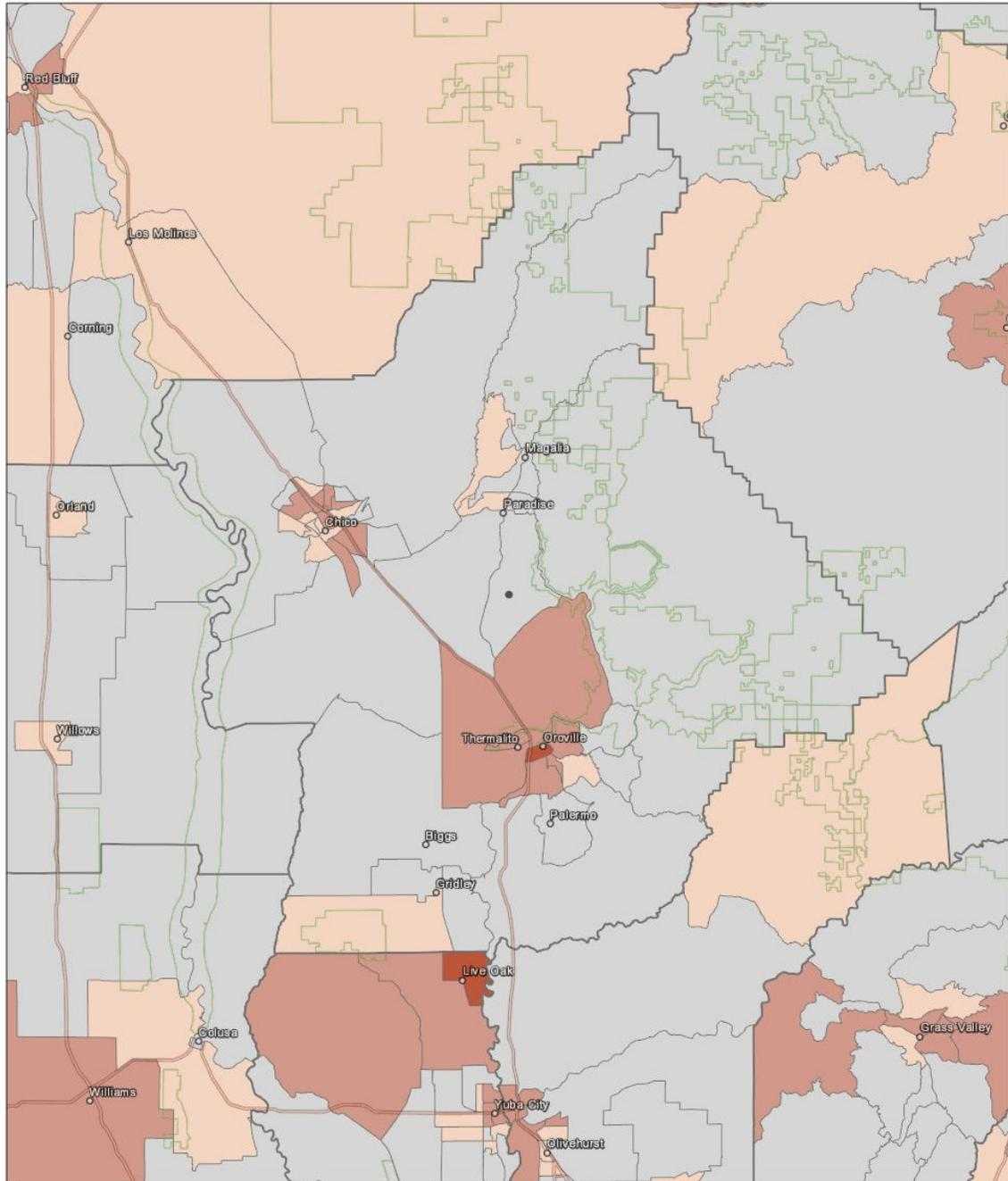

Figure 3.2: Butte County, Housing Choice Vouchers Map, 2021



12/6/2021, 10:42:02 AM

County Boundaries

(R) Housing Choice Vouchers - Tract

- No Data
- > 0 - 5%
- > 5% - 15%
- > 15% - 30%

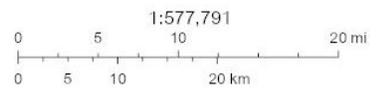

### ***Public Housing Buildings***

The map “*City of Oroville, Public Housing Buildings*” depicts the location of public housing buildings in the City in 2021. Public housing was created to provide safe and decent housing for low-income families, the elderly, and persons with disabilities. There are 54 public housing buildings which are located in clusters throughout the City. There are 24 public housing building in Census Tract 25 at the north end of the City. There are 13 public housing buildings in Census Tract 28 and 9 in Census Tract 27, located in the central parts of the City. There are eight located in the unincorporated areas of Butte County to the west of the City.

Figure 4: City of Oroville, Public Housing Buildings

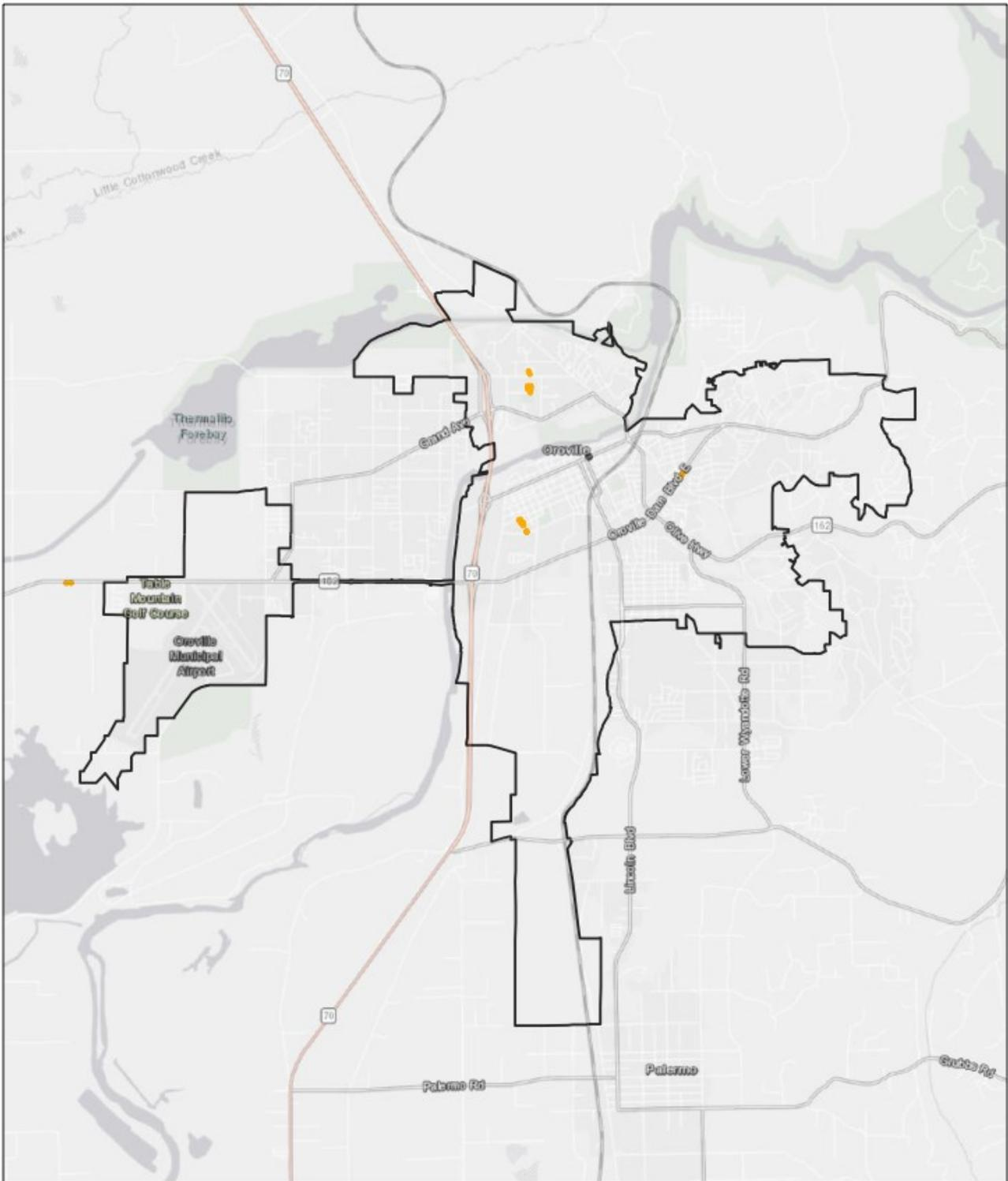

11/8/2021, 10:21:42 AM

City/Town Boundaries

(R) Public Housing Buildings

• ≤ 7 Units

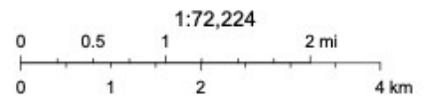

### ***Fair Housing Inquiries***

Figure 5: *City of Oroville, Fair Housing Inquiries* depicts the number of fair housing cases the City received in 2013-2021 that warrant possible discrimination. The City received 19 fair housing inquiries, and three of those were regarding a disability. The City of Oroville received significantly more housing inquiries than any other city in the County.

The map, *“Butte County, FHEO Inquires by City, 2013-2021”* depicts the geographic distribution of fair housing inquiries by residents in Butte county per one-thousand people. This data is not official cases, but represents concerns that residents have about possible discrimination. Data by city is listed below (*HCD AFFH Data Resources and Mapping Tool: U.S. Housing and Urban Development*).

**City of Chico:** Less than one fair housing inquiry per one-thousand people.

**City of Biggs:** Less than one fair housing inquiry per one-thousand people.

**City of Gridley:** Less than 0.5 fair housing inquiries per one-thousand people.

**City of Oroville:** Greater than one fair housing inquiry per one-thousand people

**Town of Paradise:** Less than 0.25 fair housing inquiries per one-thousand people.

Figure 5: City of Oroville, Fair Housing Inquiries

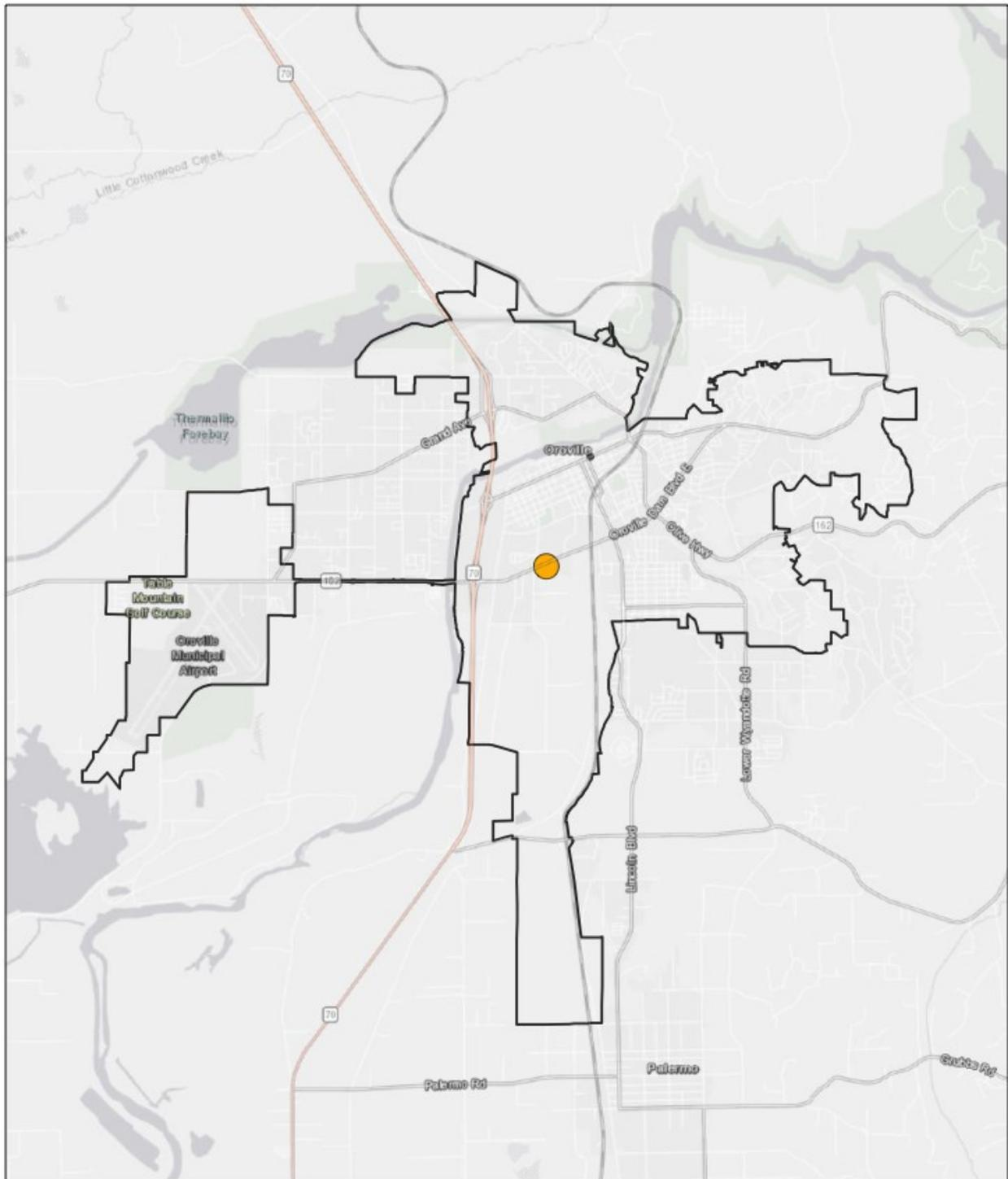

11/8/2021, 10:24:27 AM

City/Town Boundaries

(R) FHEO Inquiries by City (HUD, 2013-2021)

Greater than 1 Inquiry

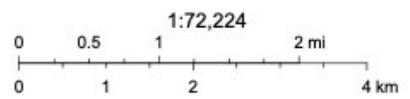
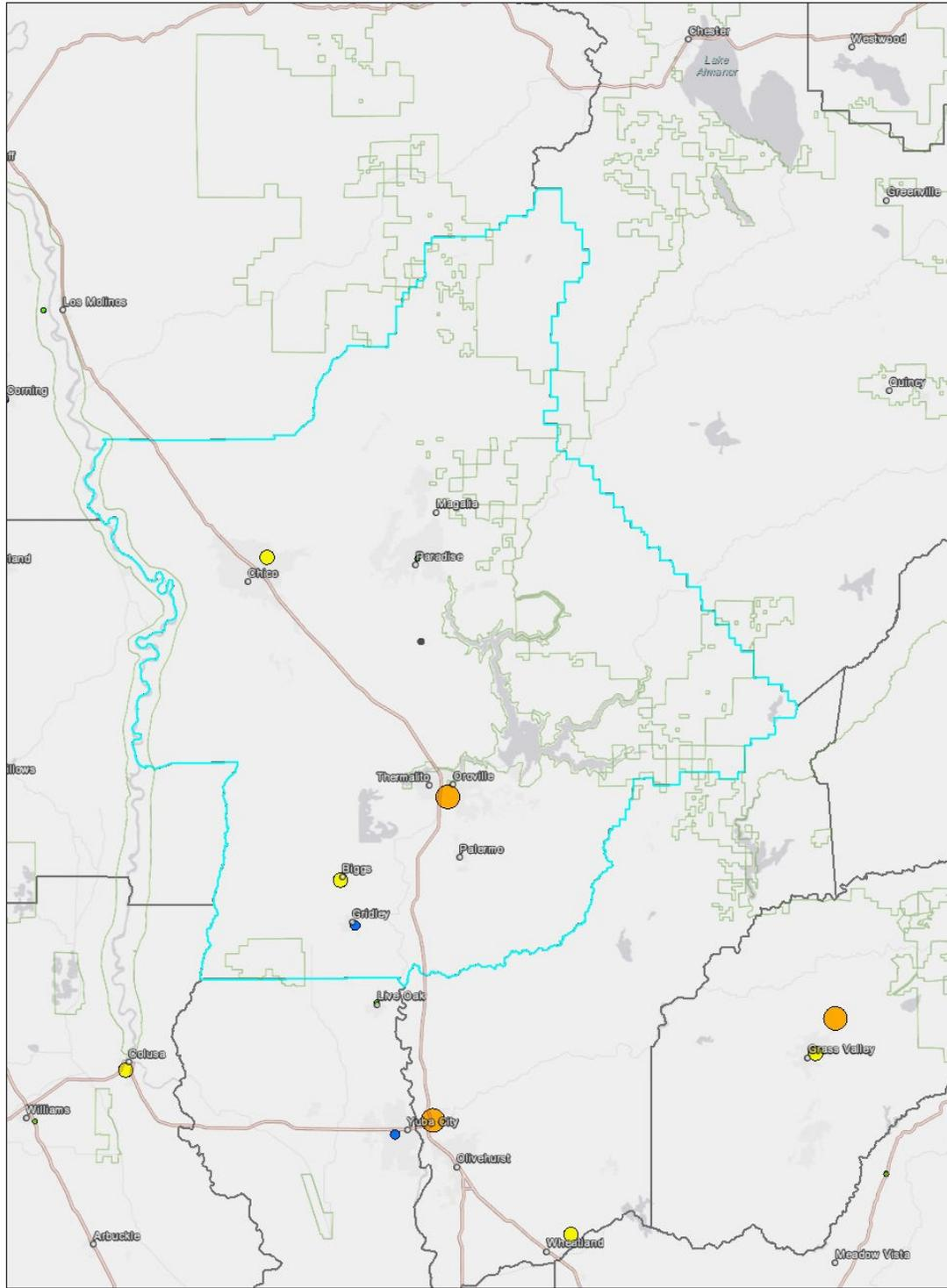
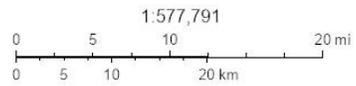

Figure 5.1: Butte County, FHEO Inquires\* by City Map, 2013-2021



3/28/2022, 4:07:30 PM

- County Boundaries
- (R) FHEO Inquiries by City (HUD, 2013-2021)
- < .25 Inquiries
- < .5 Inquiries
- < 1 Inquiry
- Greater than 1 Inquiry



Esri, HERE, Garmin, (c) OpenStreetMap contributors, and the GIS user community  
Esri, HERE, Garmin, © OpenStreetMap contributors, and the GIS user community

**Figure 5.2: Butte County, FHEO Cases - Total Map, 2020** depicts Title VIII fair housing cases filed by FHEO in Butte county per one-thousand people. Butte county had one case filed, thus the map illustrates less than 0.01 cases per one-thousand people (*HCD AFFH Data Resources and Mapping Tool: U.S. Housing and Urban Development*).

**Figure 5.3: Butte County, FHEO Cases – Disability Bias Map, 2020** depicts the percent of total cases with a disability bias for Title VIII fair housing cases filed by FHEO in Butte county per one-thousand people. Butte county had one case filed and that one case was for disability bias. Thus, the map shows greater than 85% of total cases as having a disability bias (*HCD AFFH Data Resources and Mapping Tool: U.S. Housing and Urban Development*).

**Figure 5.4: Butte County, FHEO Cases – Race Bias Map, 2020** depicts the percent of total cases with a race bias for Title VIII fair housing cases filed by FHEO in Butte county per one-thousand people. Butte county had one case filed and that one case was not for race bias. Thus, the map shows 0% of total cases as having a race bias (*HCD AFFH Data Resources and Mapping Tool: U.S. Housing and Urban Development*).

Figure 5.2: Butte County, FHEO Cases - Total Map, 2020

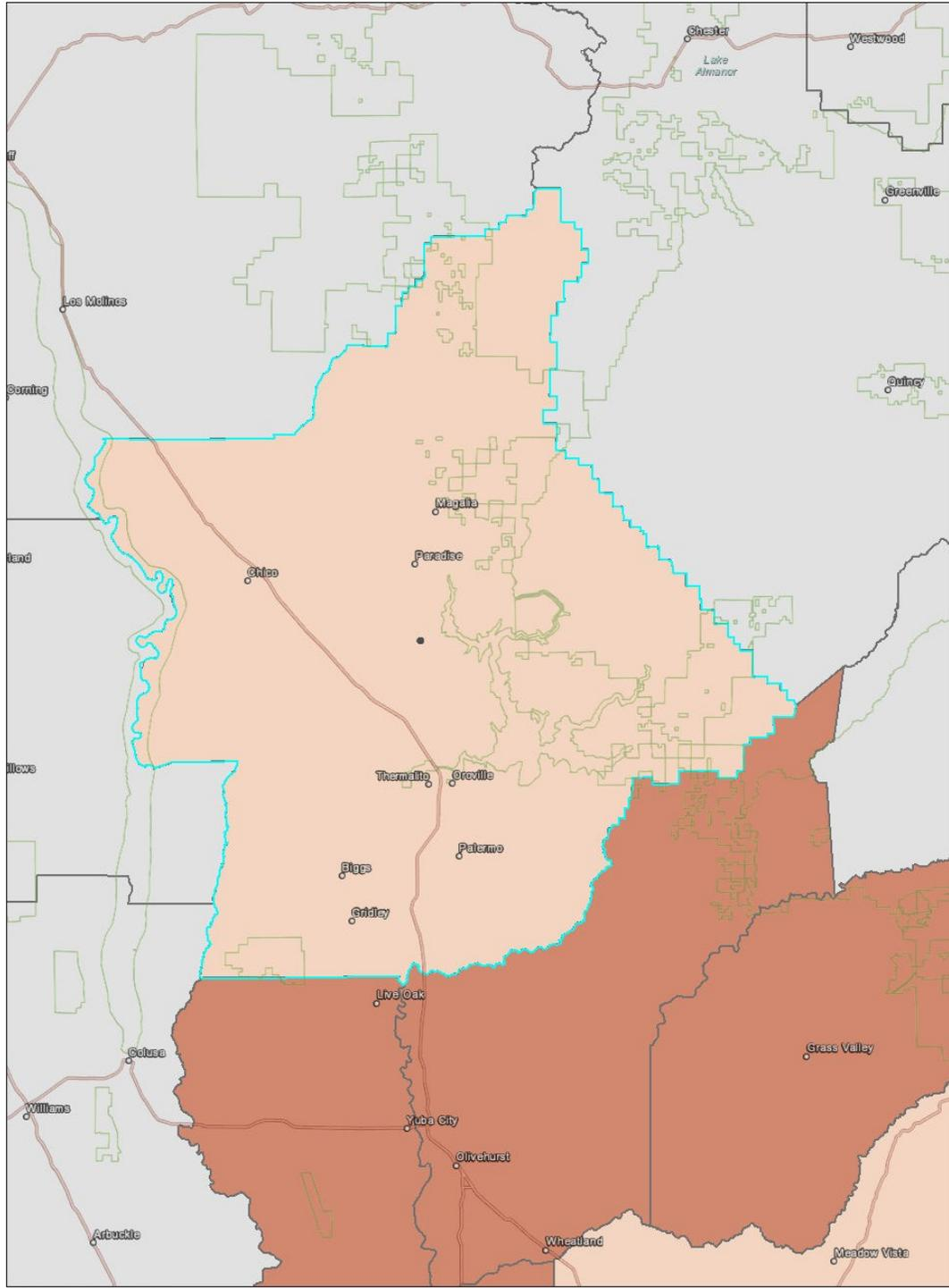

3/28/2022, 4:04:59 PM

-  County Boundaries
- (A) FHEO Cases - Total (2020) - County
-  0 Cases
-  < .01 Cases
-  .01 - .025 Cases

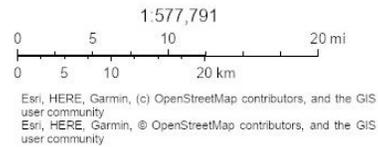

Figure 5.3: Butte County, FHEO Cases – Disability Bias Map, 2020

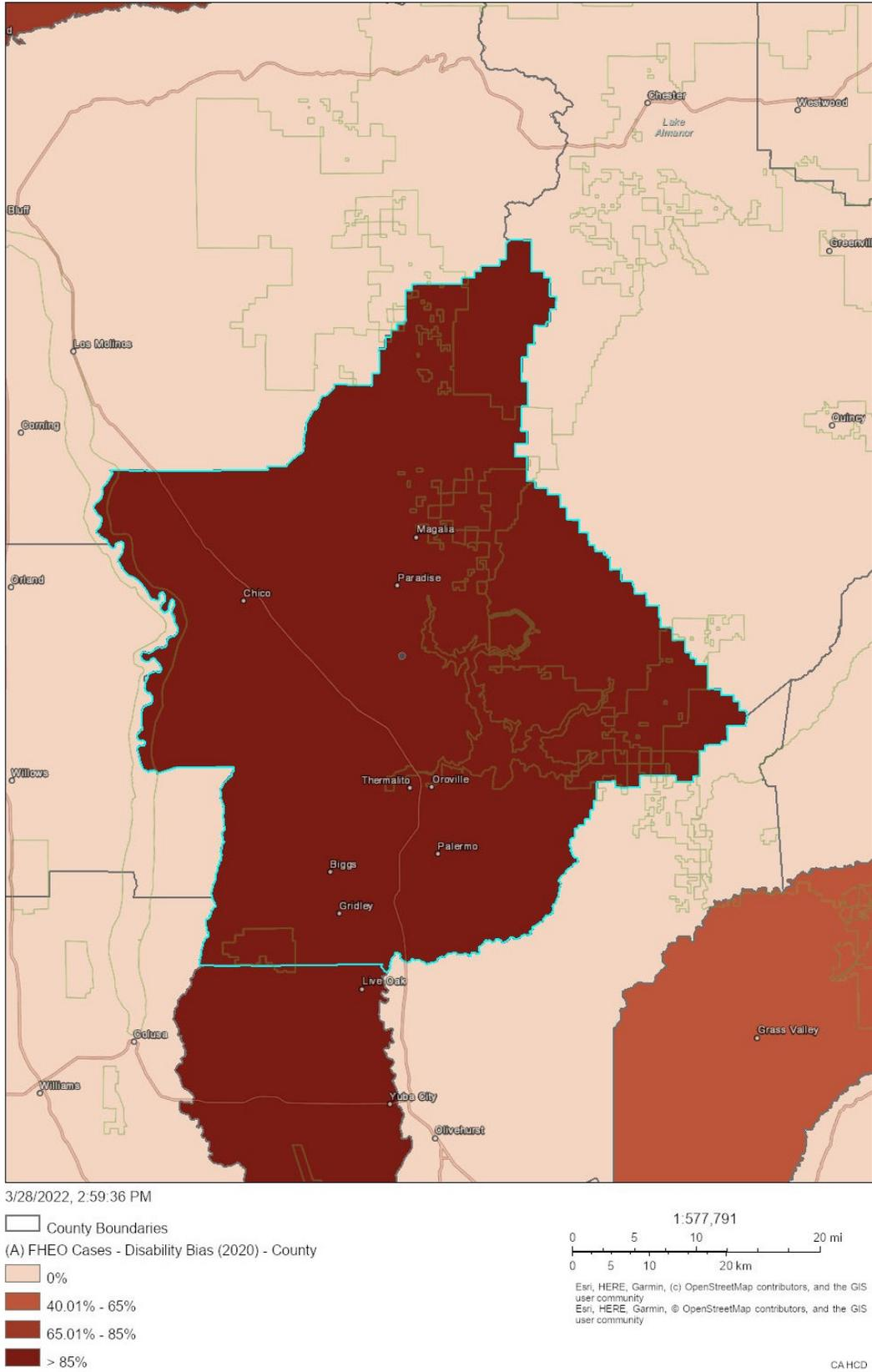
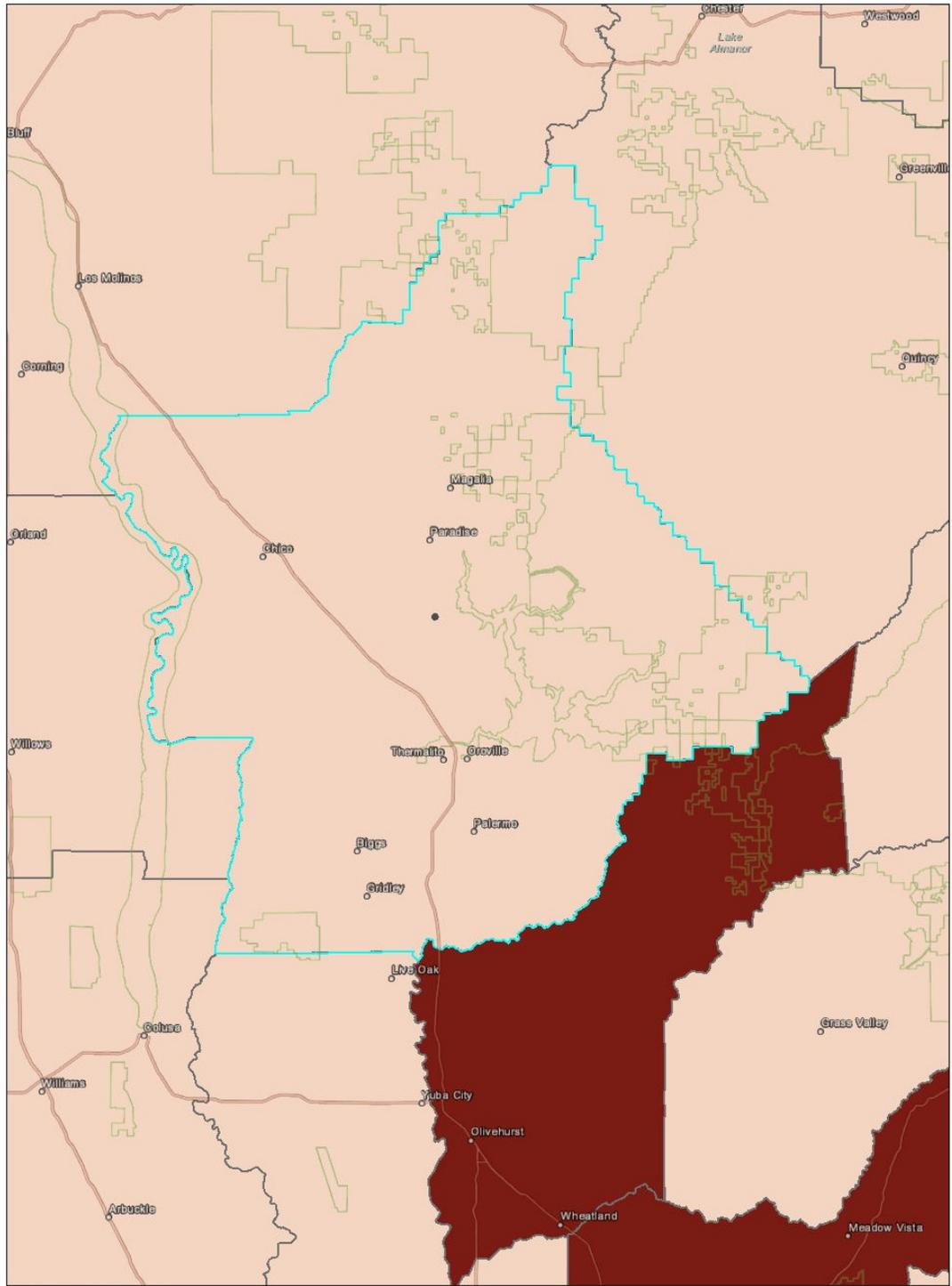

Figure 5.4: Butte County, FHEO Cases – Race Bias Map, 2020



3/28/2022, 2:54:12 PM

- County Boundaries
- (A) FHEO Cases - Race Bias (2020) - County
  - 0%
  - > 50%

1:577,791  
0 5 10 20 mi  
0 5 10 20 km

Esri, HERE, Garmin, (c) OpenStreetMap contributors, and the GIS user community  
Esri, HERE, Garmin, © OpenStreetMap contributors, and the GIS user community

## ***Local Data and Knowledge***

Local data and knowledge was collected through interviews with regional stakeholders whose service areas include the City of Oroville.

### **Legal Services of Northern California**

On August 12, 2021, authors conducted an online interview over Zoom with a staff member from the Legal Services of Northern California (LSNC) office in Chico, which provides legal services to low-income residents (200% of the poverty level) residing Butte, Tehama, and Glenn Counties. LSNC's goal is to identify and defeat the causes and effects of poverty by utilizing all available resources. LSNC provides legal services for housing, government benefits, health, and other civil legal issues.

Staff works with residents in Butte and Glenn County who are 60 years and over and have significant disabilities that impact their ability to work or secure housing. Many clients have trouble finding and acquiring housing due to mental illness, credit requirements, and lack of financing for security deposits. Staff indicated there is a need for supportive housing that provides wraparound services. Landlords also need support or education to better assist clients that have special needs.

Due to lack of housing in the region, clients have been unable to utilize Housing Choice (Section 8) and Emergency Housing Vouchers. Furthermore, there is a shortage of accessible units in the region. Staff reported that recent wildfires destroyed naturally occurring affordable housing such as mobile home parks, market-rate substandard housing, and apartment complexes in the burn scar. The Town of Paradise in Butte County lost 40 mobile home parks, which have not been restored or reintroduced.

Staff noted that fair housing issues are often reported to the state, not municipalities. Therefore, the number of fair housing cases within cities is likely larger.

### **City of Oroville**

The City would like to improve outreach by integrating its services with the County. Currently, affordable housing programs and services are difficult for residents to navigate because City and County services may conflict or overlap and there is not a singular point-of-contact to answer questions. The City has conducted fair housing outreach by distributing flyers to various organizations and posting ads to radios and local newspapers in English, Spanish, and Hmong. However, the City has not conducted fair housing enforcement, which is beyond the City's organizational capacity. The City of

Oroville does not have a formal process to receive, review, and respond to fair housing complaints. Due to limited staff and capacity, fair housing complaints are referred to either Legal Services of Northern California, the California Department of Fair Employment and Housing, or the U.S. Department of Housing and Urban Development's Fair Housing and Equal Opportunity (FHEO) office.

In addition, the City does not have the capacity to promote fair housing through outreach. However, the staff has hosted two community workshops in the South Oroville neighborhood to assess community needs and prioritize areas and opportunities for investment. Workshops have focused on topics such as housing, infrastructure, code enforcement, and neighborhood watch.

### ***Summary of Findings***

As of 2021, 552 households held Housing Choice Vouchers in the City, which is a significantly high number, at 25% of all renter households. Census Tract 28 has the highest concentration of HCVs, at 15-30% of renter-occupied housing units and Census Tract 31 has the lowest concentration of HCVs at 0-5% of renter-occupied housing units. Many of the census tracts surrounding Thermalito and Oroville have 5-15% of renter occupied housing units as households with an HCV. The city of Oroville is the only area in the county with 15-30% of renter occupied housing units as households with an HCV

Of the 54 public housing buildings in the City, 13 are in Census Tract 28 and 24 in Census Tract 25. The City has received 19 fair housing inquiries in 2013-2021, which is significantly high compared to other cities in Butte County. These findings indicate that there is a concentration of affordable housing in Census Tract 28 and significantly less affordable housing in Census Tract 31. In addition, there are a significant number of fair housing issues occurring in the City.

Interviews with Legal Services of Northern California indicate that households who have been awarded Housing Choice or Emergency Vouchers may not be able to utilize them due to the shortage of housing in Butte County.

The City of Oroville does not have a formal fair housing complaint, review, and enforcement process. Therefore, residents report fair housing inquiries to local agencies and state governments. The City would like to integrate its services with the County to improve fair housing outreach.

## B. SEGREGATION AND INTEGRATION

---

The second subsection of the Assessment of Fair Housing is an assessment of segregation and integration in the jurisdiction. Segregation is defined as housing policies, practices, or procedures – both public and private - that exclude or separate individuals based on their race, ethnicity, disability, or income. This can include overt and covert housing discrimination through land use policy, shifting housing markets, and patterns of investment or disinvestment. Historic patterns of segregation persist in California despite the Fair Housing Act in 1968. The analysis of integration considers the equal distribution of people and resources within communities (*California Department of Housing and Community Development, Affirmatively Furthering Fair Housing, April 2021 Update*).

### *Local and Regional Patterns and Trends*

This section includes data tables, narratives, and maps to illustrate local and regional patterns and trends regarding segregation and integration. For the purposes of this analysis, segregation and integration includes trends and place-based data on race and ethnicity, linguistic isolation, familial status, persons with disabilities, and income disparity, and identifies the groups that experience the highest levels of segregation.

### *People of Color*

The table “*City of Oroville and Butte County, Race and Ethnicity, 2010 and 2019*” compares data on race and ethnicity for the City of Oroville and Butte County from in 2010 and 2019. As of 2019, most of the population or 64.2% of residents identify as White (not Hispanic/Latino), 13.6% identify as Hispanic or Latino (of any race), and 8.6% identify as Asian in the City of Oroville. The remainder of the population identify as two or more races, Black/African American, American Indian/Alaska Native, and Native Hawaiian/Other Pacific Islander.

The City of Oroville experienced a large increase in population of 26.2% from 2010 to 2019, while Butte County’s population only increased by 3.3% over that period. This is likely due in part to the 2018 Camp Fire and residents relocating from eastern Butte County to the City of Oroville. The City of Oroville’s Asian population increased by 3.4% and the Hispanic/Latino population increased by 3.2%. The number of White, not Hispanic/Latino individuals increased by 965 individuals, but the overall percentage decreased by 10.5% due to significant increases in non-white populations.

In comparison, Butte County’s Asian population increased by 0.5% and its Hispanic/Latino population increased by 2.8%. The number of White, not Hispanic/Latino individuals decreased by 3,926 individuals and the overall percentage decreased by 4.1%. The City of Oroville is steadily becoming more diverse.

Figure 6: City of Oroville and Butte County, Race and Ethnicity Table, 2010 and 2019

Item 4.

Race or Ethnicity	City of Oroville					Butte County				
	2010		2019		2010-2019	2010		2019		2010-2019
	Number of Persons	Percent of Total Population	Number of Persons	Percent of Total Population	Change	Number of Persons	Percent of Total Population	Number of Persons	Percent of Total Population	Change
Hispanic/Latino (of any race)	1,600	10.4%	2,646	13.6%	+3.2%	29,512	13.5%	36,916	16.3%	+2.8%
White, not Hispanic/Latino	11,480	74.7%	12,445	64.2%	-10.5%	166,463	76.1%	162,537	72%	-4.1%
Black or African American, not Hispanic/Latino	445	2.9%	801	4.1%	+1.2%	3,012	1.4%	3,342	1.5%	+0.1%
American Indian and Alaska Native, not Hispanic/Latino	139	0.9%	265	1.4%	+0.5%	2,050	0.9%	1,699	0.8%	-0.1%
Asian, not Hispanic/Latino	801	5.2%	1,674	8.6%	+3.4%	8,658	4%	10,057	4.5%	+0.5%
Native Hawaiian and Other Pacific Islander, not Hispanic/Latino	24	0.2%	89	0.5%	+0.3%	481	0.2%	476	0.2%	0%
Some other race, not Hispanic/Latino	0	0%	8	0%	0%	243	0.1%	321	0.1%	0%
Two or more races, not Hispanic/Latino	880	5.7%	1,465	7.6%	+1.9%	8,216	3.8%	10,469	4.6%	+0.8%
<b>Total</b>	<b>15,369</b>	<b>--</b>	<b>19,393</b>	<b>--</b>	<b>+26.2%</b>	<b>218,635</b>	<b>--</b>	<b>225,817</b>	<b>--</b>	<b>+3.3%</b>

Source: U.S. Census 2006-2010 and 2015-2019 American Community Survey

***Continued...***

The maps *“City of Oroville, Percent of People of Color, 2018,” “City of Oroville, Percent of People of Color, 2010,” “Butte County, Percent of People of Color, 2018,”* and *“Butte County, Percent of People of Color, 2010”* depict block group data on the total percentage of people of color, or the non-white population for residents in the City of Oroville and Butte County in 2010 and 2018.

For the purposes of this analysis, non-white individuals are those that identify as any other racial or ethnic subgroup than “White,” including individuals that identify as two or more races. People who identify as nonwhite are considered “people of color.”

In most areas of the City in 2018, the percentage of the total non-white population ranges from 21-40%. However, the percentage of the total non-white population ranges from 41-60% in areas falling in Census Tracts 25, 29, 30.01, 30.02, and 33. The highest concentration of non-white residents ranges from 61-80%, and these areas fall within Census Tract 30.01.

In Butte County in 2018, the portion of non-white residents is significantly smaller, ranging from 20-40% in roughly half of the County and less than 20% in the other half. There are few areas that have a concentration of non-white residents ranging from 41-60% in the County. These areas fall within Oroville, Biggs, Chico, and Gridley, and southern portions of the County.

The percent of the total non-white population increased significantly in both the City of Oroville and Butte County in 2018 compared to 2010. In 2010, less than 20% of the population was non-white in most areas of Butte County. In 2010, Census Tract 25, 29, and 33 in the City of Oroville had a non-white population of 21-40% and Census Tracts 30.01 and 30.02 had a non-white population ranging from 21-60%. The concentration of non-white residents increased to 41-80% in Census Tracts 30.01 and 30.02 and 41-60% in Census Tracts 25, 29, and 33 in 2018 compared to 2010. The maps below depict that diversity has substantially increased in all parts of Butte County between 2010 and 2018. Trends over time indicate the City’s growth in diversity was concentrated within Census Tracts 25, 29, 30.01, 30.02, and 33.

Figure 6.1: City of Oroville, Percent of People of Color Map, 2018

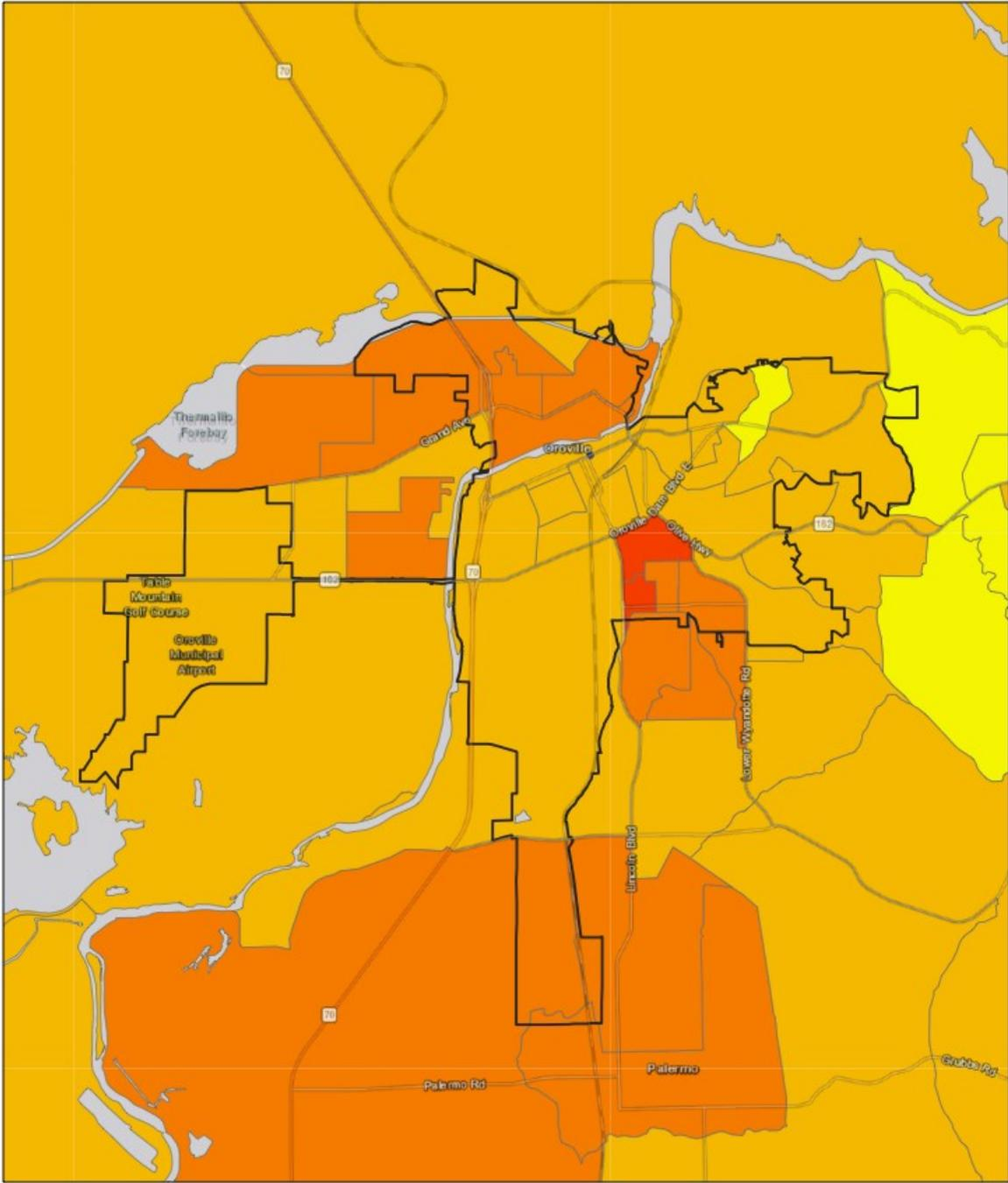

11/8/2021, 10:23:08 AM

City/Town Boundaries

(R) Racial Demographics (2018) - Block Group

- ≤ 20%
- 21 - 40%
- 41 - 60%
- 61 - 80%

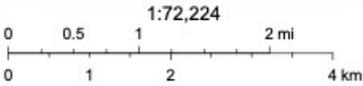
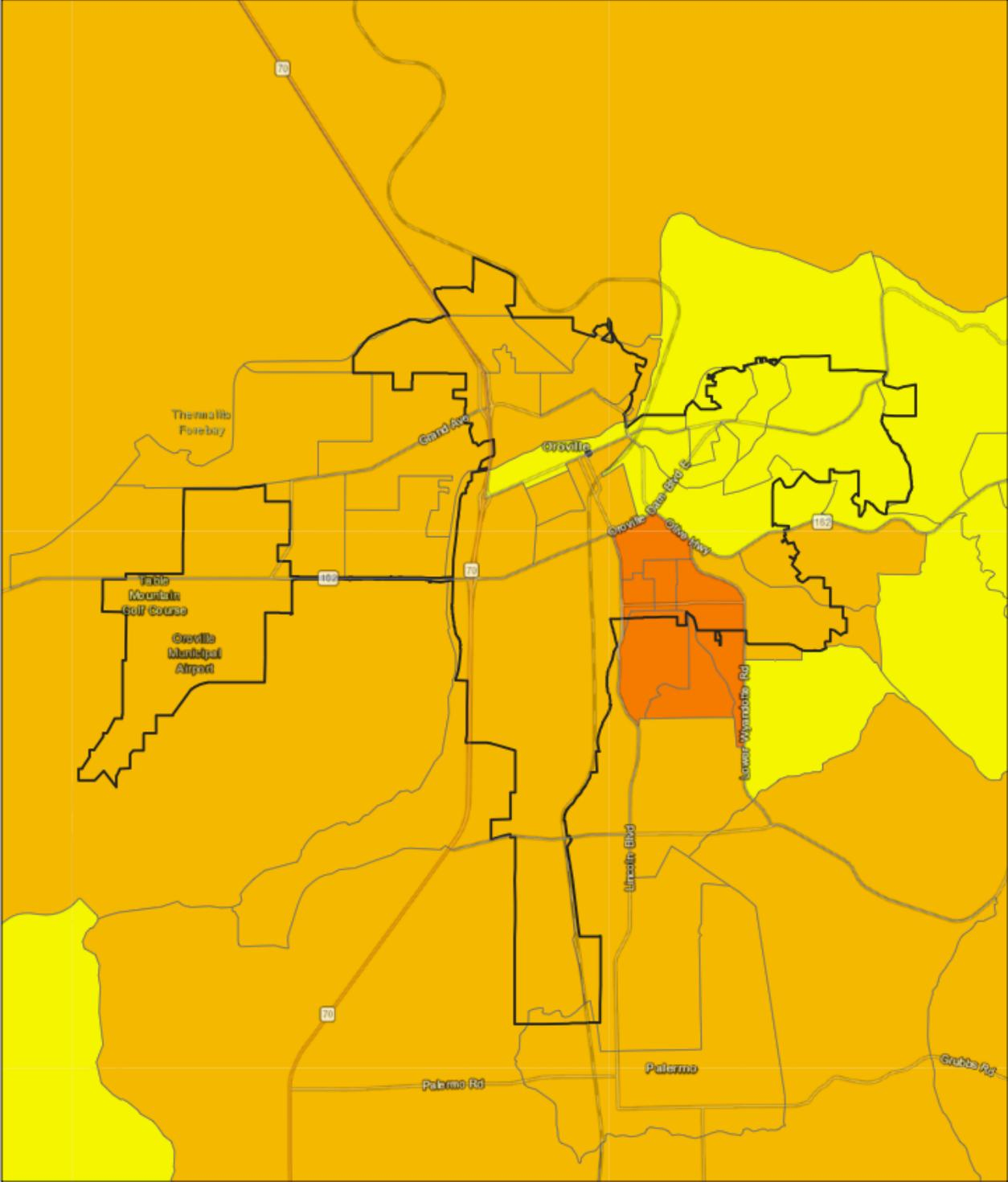

Figure 6.2: City of Oroville, Percent of People of Color Map, 2010



11/8/2021, 10:30:48 AM

City/Town Boundaries

(A) Racial Demographics (2010) - Block Group

- ≤20%
- 21 - 40%
- 41 - 60%

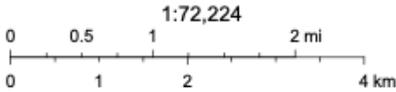
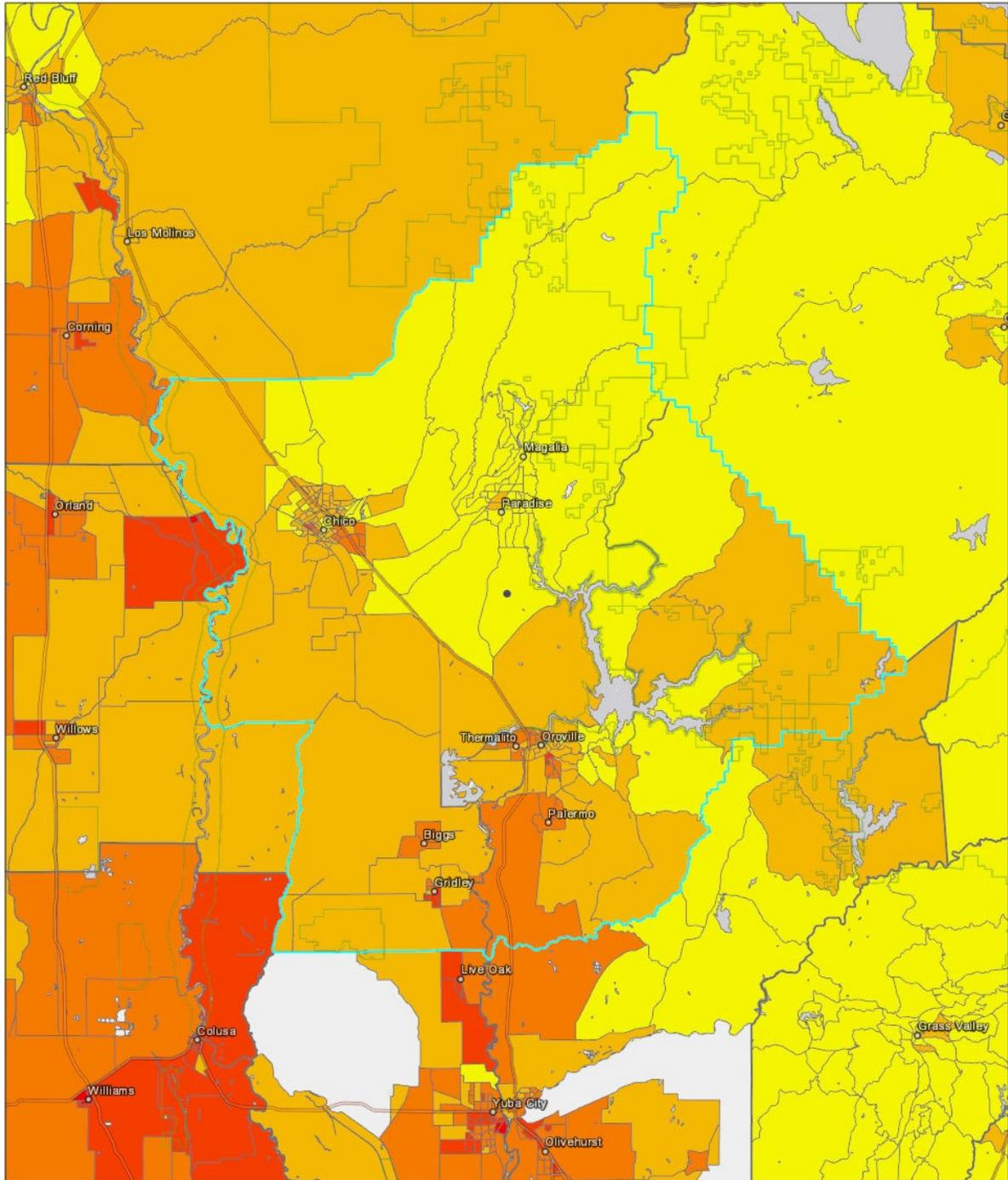

Figure 6.3: Butte County, Percent of People of Color Map, 2018



10/25/2021, 11:45:27 AM

County Boundaries

(R) Racial Demographics (2018) - Block Group

- ≤ 20%
- 21 - 40%
- 41 - 60%
- 61 - 80%
- > 81%

1:577,791

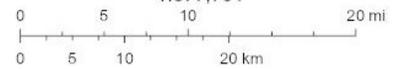
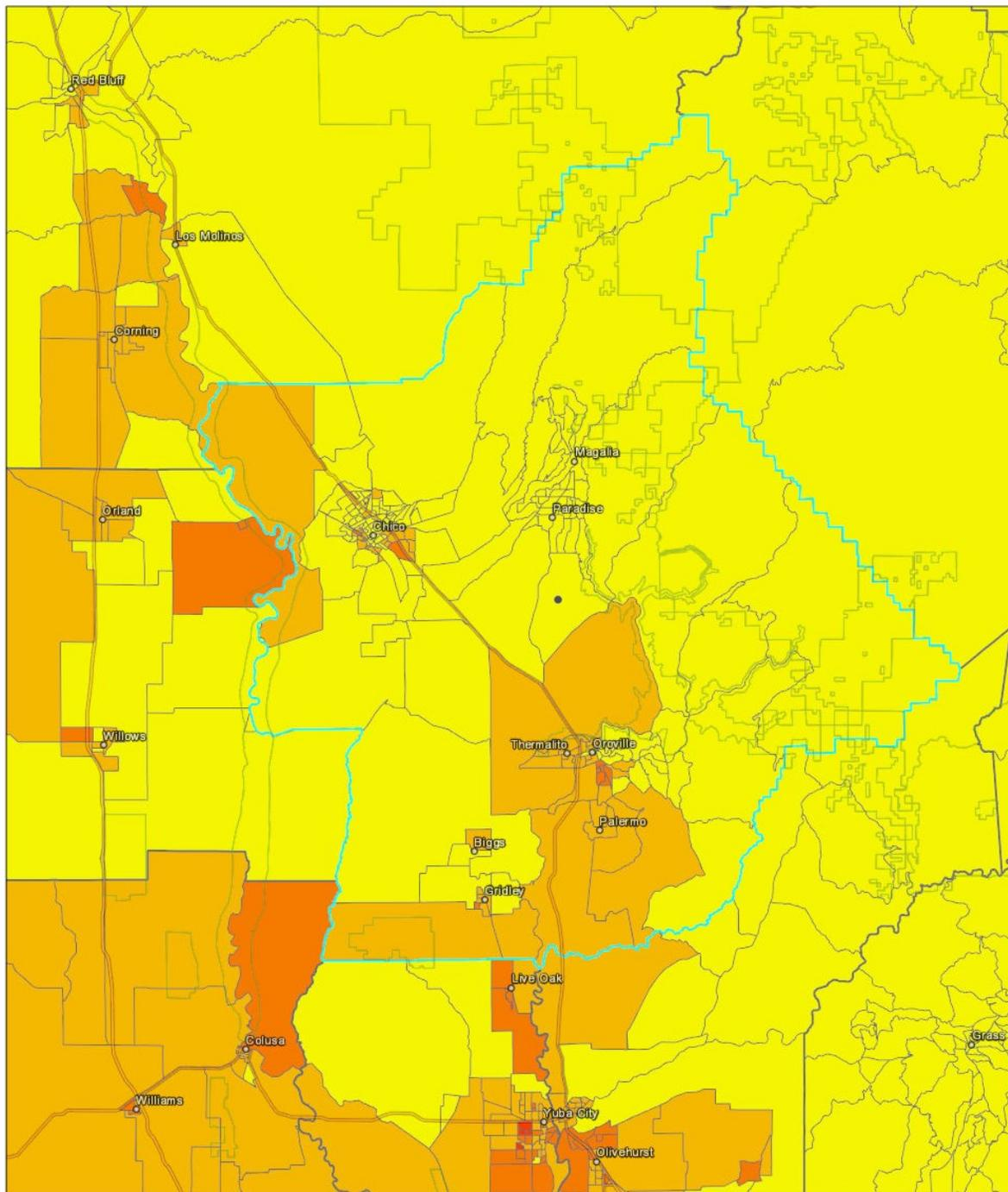

Figure 6.4: Butte County, Percent of People of Color Map, 2010



10/25/2021, 11:47:51 AM

County Boundaries

(A) Racial Demographics (2010) - Block Group

- ≤20%
- 21 - 40%
- 41 - 60%
- 61 - 80%

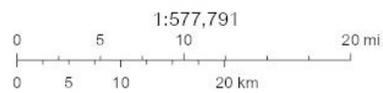

### *Linguistic Isolation: Language*

The table “*City of Oroville and Butte County, Languages Spoken at Home, 2010 and 2019*” compares data on language and fluency for the City of Oroville and Butte County in 2010 and 2019. In 2019, more than 15.5% of the population spoke a language other than English at home, with Asian and Pacific Islander languages as the most common language at 6.6%, Spanish at 5.6%, and other Indo-European languages at 2.4% of the population. An estimated 6.8% of the total population is not fluent in English.

The percentage of people who spoke a language other than English at home increased by 4% for the City of Oroville and decreased by 2.6% for Butte County in 2019 compared to 2010. In addition, the number of persons over 5 years of age who are not fluent in English increased slightly for the City of Oroville but decreased slightly for Butte County. Households that experience linguistic isolation speak limited English, which can make it difficult to access the information or services they need. About 1,200 individuals are not fluent in English, which is nearly half of the population that speaks a language other than English at home.

Figure 7: City of Oroville and Butte County, Languages Spoken at Home Table, 2010 and 2019

Language & Fluency	City of Oroville					Butte County				
	2010		2019		2010-2019	2010		2019		2010-2019
	Number of Persons	Percent of Total Population	Number of Persons	Percent of Total Population	Change	Number of Persons	Percent of Total Population	Number of Persons	Percent of Total Population	Change
Persons 5 years and over that speak Spanish at home	747	5.3%	997	5.6%	+0.3%	19,196	9.3%	20,877	9.8%	+0.5%
Persons 5 years and over that speak Asian and Pacific Islander languages at home	651	4.6%	1,169	6.6%	+2%	5,986	2.9%	7,482	3.5%	+0.6%
Persons 5 years and over that speak other Indo-European languages	156	1.1%	432	2.4%	+1.3%	4,334	2.1%	3,208	1.5%	-0.6%
Persons 5 years and over that speak other languages at home	68	0.5%	155	0.9%	+0.4%	619	0.3%	1,104	0.5%	+0.2%
Total persons 5 years and over that speak a language other than English at home	1,627	11.5%	2,753	15.5%	+4.0%	30,135	14.6%	20,692	12%	-2.6%
Total persons 5 years and over that are not fluent in English	809	5.7%	1,207	6.8%	+1.1%	12,591	6.1%	11,570	5.4%	-0.7%

Source: U.S. Census 2006-2010 and 2015-2019 American Community Survey

## Familial Status

To assess segregation and integration of familial status, this report analyzes data on percent of children in single parent, female households, and percent of children in married couple households within the City of Oroville and Butte County. Census tract level data is used because block group level data is not available.

### *Married Couple Households*

The maps “*City of Oroville, Married Couple Households with Children, 2019*” and “*Butte County, Married Couple Households with Children, 2019*” indicate the percent of children residing in married couple households in the City of Oroville and Butte County. Living arrangements for children vary significantly within the City, ranging from 20% to greater than 80% of children residing in married couple households.

In Census Tract 31, greater than 80% of children reside in married couple households, which is the highest concentration in the entire City. In Census Tracts 27, 29, 30.01, and 33 that figure is 60-80% of households. However, in Census Tracts 25, 28, and 27 only 40-60% of children reside in married couple households. Census Tract 30.02 has the lowest concentration at 20-40% of households.

Similarly, in Butte County, the number of children residing in married couple households range from 21-61%. However, Census Tract 30.02 has one of the lowest concentrations of children residing in married couple households in the entire County (*HCD AFFH Data Resources and Mapping Tool: U.S. Census 2015-2019 American Community Survey*).

Figure 8: City of Oroville, Percent of Children in Married Couple Households Map, 2019

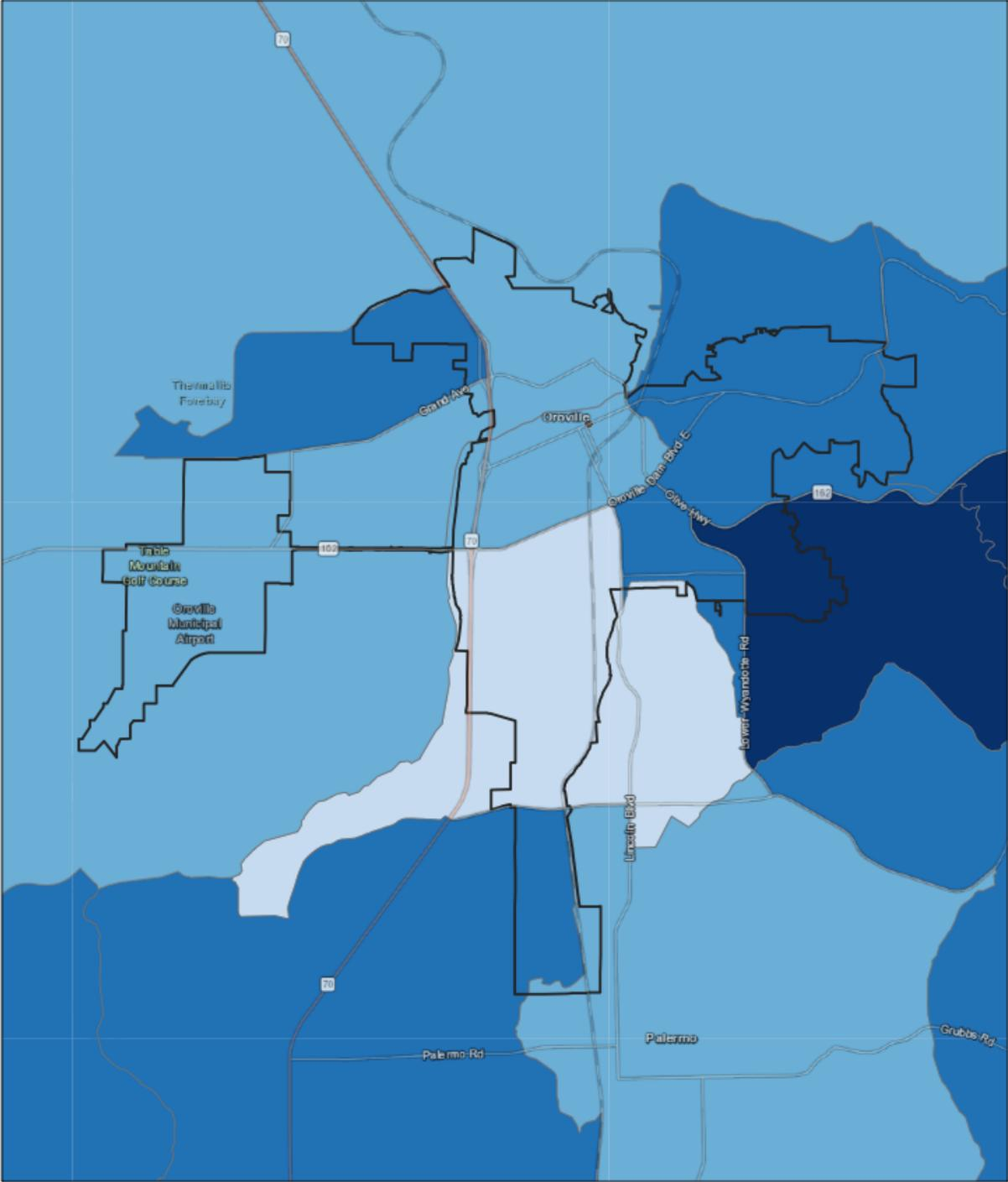

11/8/2021, 11:18:18 AM

City/Town Boundaries

(R) Percent of Children in Married - Couple Households (ACS, 2015-2019) - Tract

- 20% - 40%
- 40% - 60%
- 60% - 80%
- > 80%

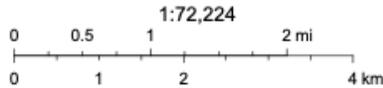
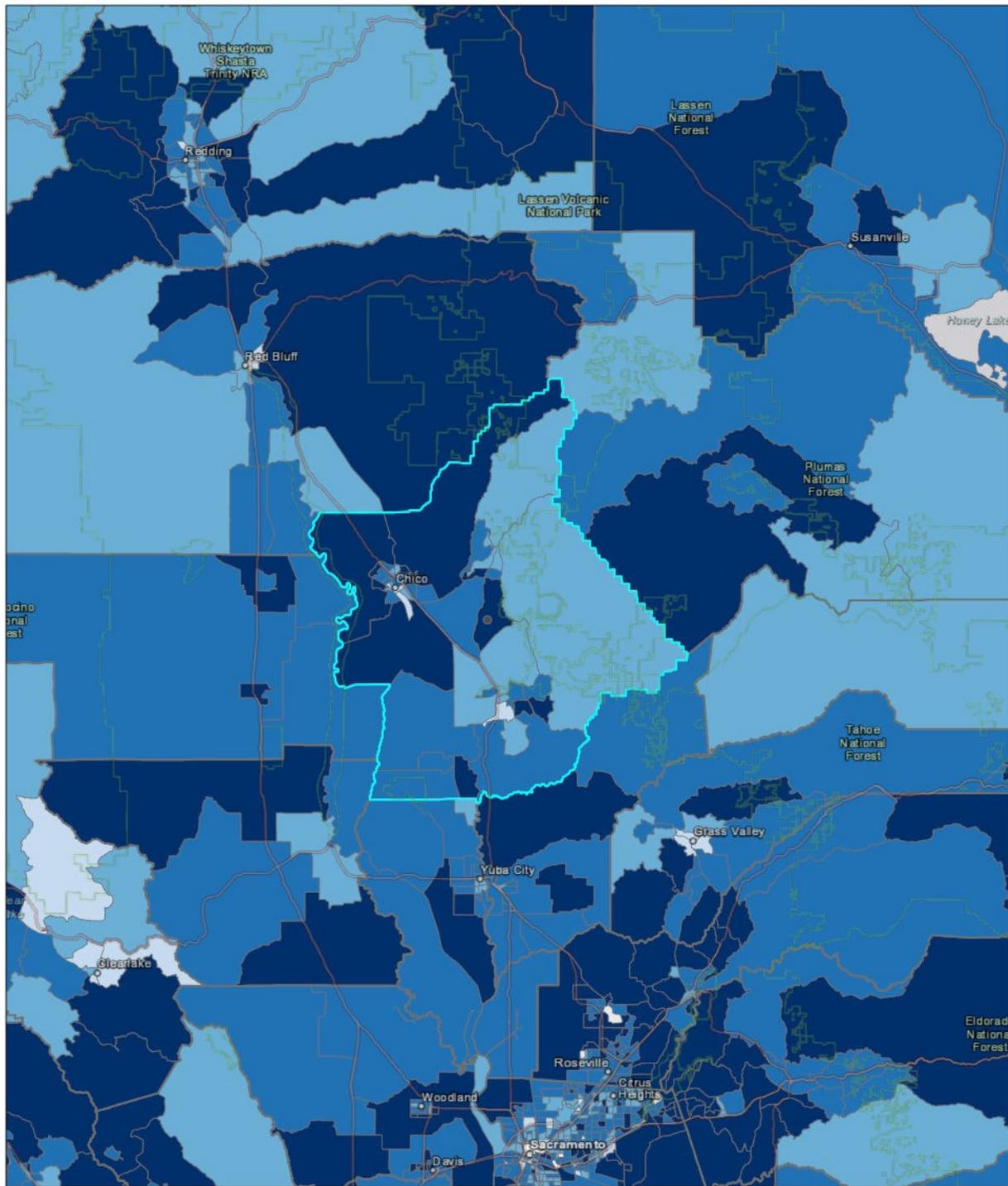

Figure 8.1: Butte County, Percent of Children in Married Couple Households Map, 2019



10/25/2021, 9:55:29 AM

County Boundaries

(R) Percent of Children in Married - Couple Households (ACS, 2015-2019) - Tract

- < 20%
- 20% - 40%
- 40% - 60%
- 60% - 80%
- > 80%

1:1,155,581  
0 10 20 40 mi  
0 15 30 60 km

### ***Single Parent, Female Households***

The maps “*City of Oroville, Percent of Children in Single Parent, Female Households, 2019*” and “*Butte County, Percent of Children in Single Mother Households, 2019*” indicate the percent of children residing in female householder, no spouse/partner present households in the City of Oroville and Butte County.

The findings indicate that 20-40% of children reside in households headed by single mothers in Census Tracts 28, 30.01, 30.02, and 37. Less than 20% of children reside in households headed by single mothers in Census Tracts 25, 27, 29, 31, and 33.

In most areas of Butte County, less than 20% of children live in households headed by single mothers. In some areas of Butte County, such as northern parts of the County, south Oroville, south Chico, and the City of Gridley, 20-40% of children reside in households headed by single mothers. The City of Oroville is one of few areas in the County where greater than 20% of households are headed by single mothers (*HCD AFFH Data Resources and Mapping Tool: U.S. Census 2015-2019 American Community Survey*).

Figure 8.2: City of Oroville, Percent of Children in Single Parent, Female Households Map, 2019

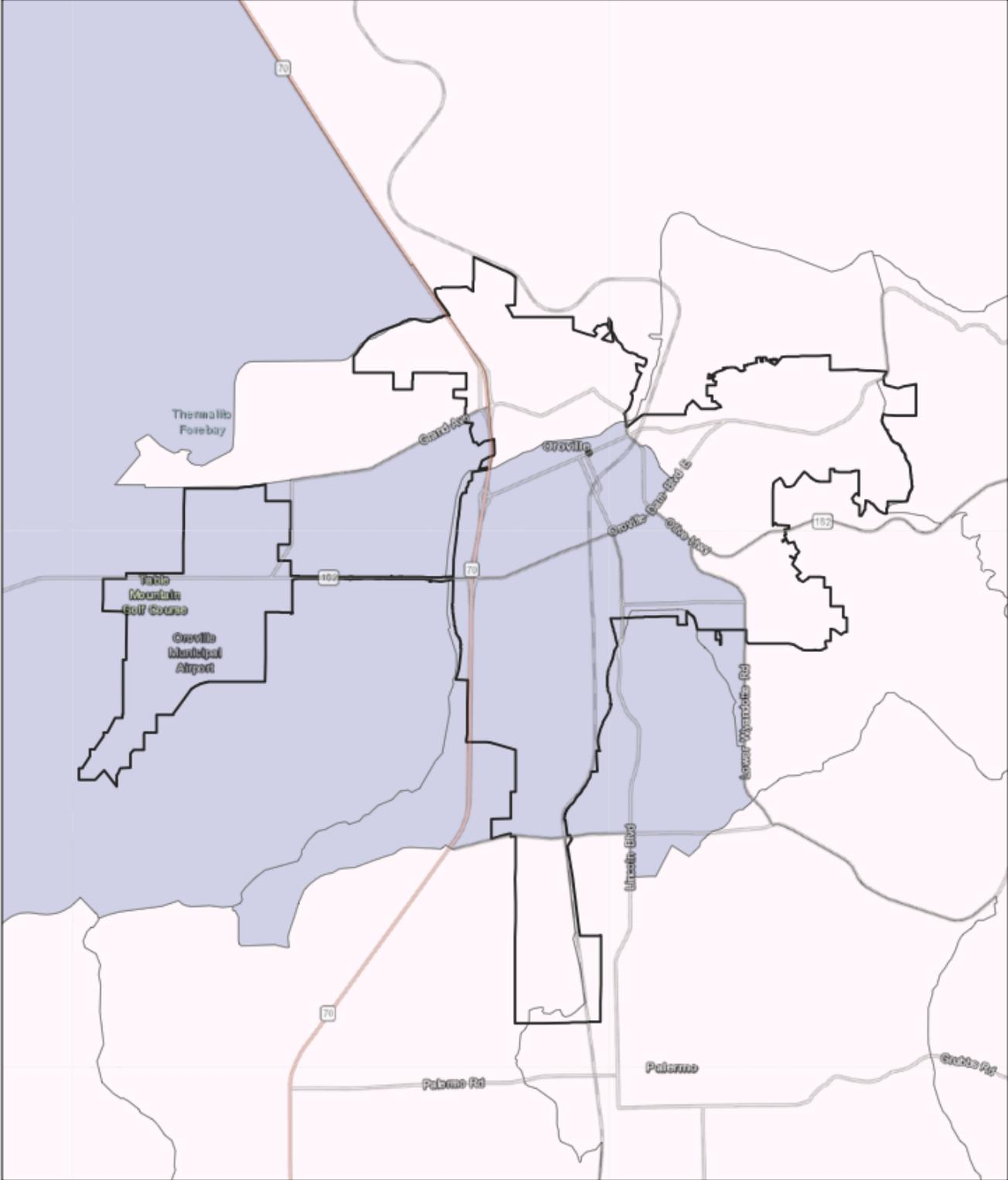

11/8/2021, 10:29:11 AM

City/Town Boundaries

(R) Percent of Children in Female Householder, No Spouse/Partner Present Households (ACS, 2015-2019) - Tract

≤ 20%

20% - 40%

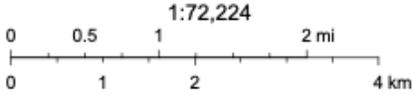
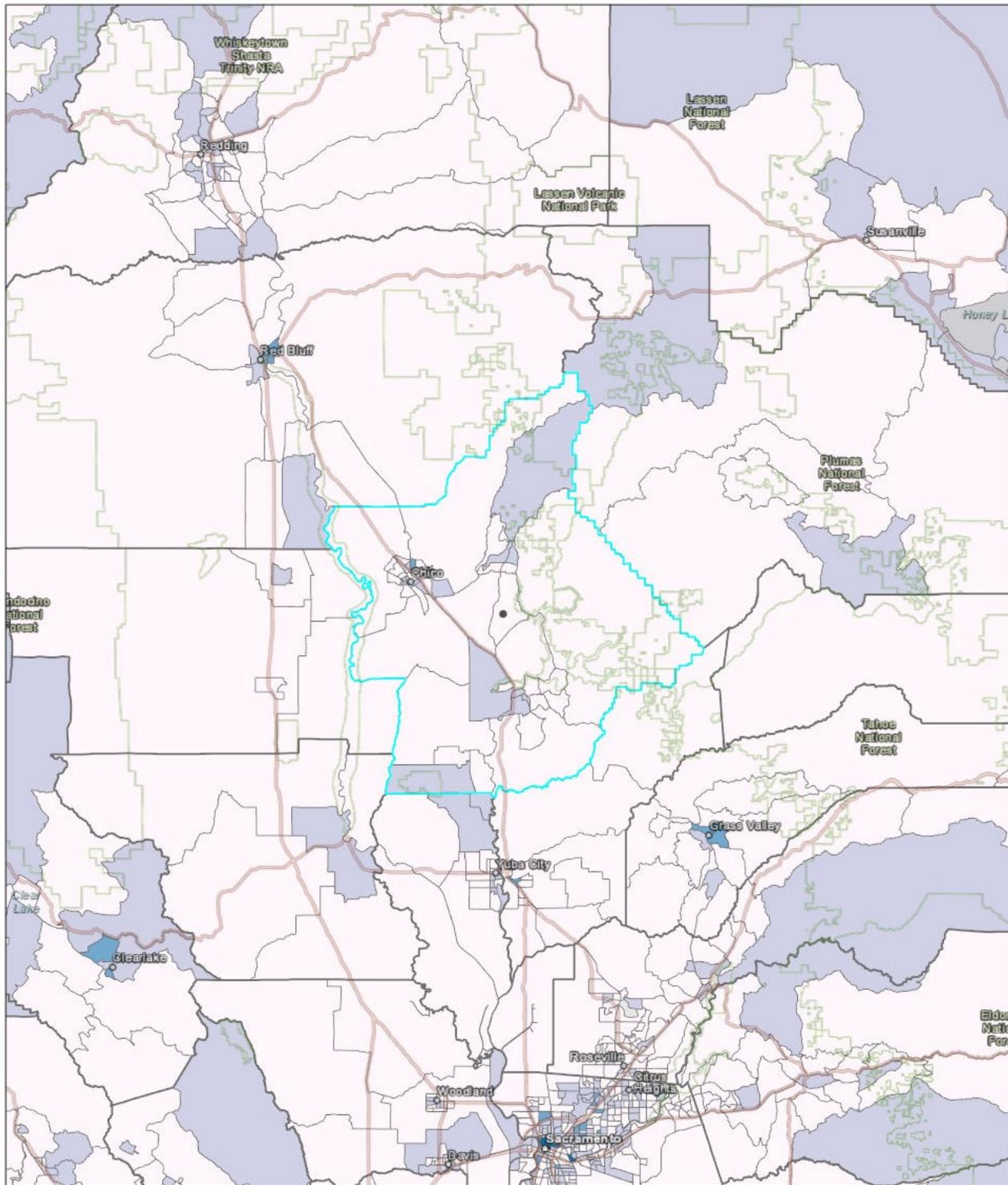

Figure 8.3: Butte County, Percent of Children in Single Parent, Female Households Map, 2019



10/25/2021, 10:09:49 AM

County Boundaries

(R) Percent of Children in Female Householder, No Spouse/Partner Present Households (ACS, 2015-2019) - Tract

- ≤ 20%
- 20% - 40%
- 40% - 60%
- 60% - 80%
- > 80%

1:1,155,581

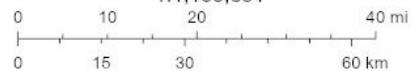

### *Single Parent Female Households Living Below the Poverty Level*

The table “City of Oroville and Butte County, Percent of Single Parent Female Households Living Below the Poverty Level, 2010 and 2019” shows the percent of single parent female households whose income in the past 12 months is below the poverty level. Over the past 10 years the City of Oroville has experienced an increase in the number of single parent female householders living below the poverty level.

The City of Oroville has experienced slight increases in single parent female households living below the poverty level in the past 10 years. Single parent female households living below the poverty level in the City of Oroville increased by 40 households in 2019 compared to 2010. Families that had related children under 18 years old of the single parent female householder and who were living below the poverty level increased by 42 households in 2019 compared to 2010.

In comparison, Butte County experienced decreases in single parent female households living below the poverty level and those with related children of the householder under 18 years in 2019 compared to 2010

**Figure 8.4: City of Oroville and Butte County, Percent of Single Parent Female Households Living Below the Poverty Level Table, 2010 and 2019**

Percent of Families Whose Income in the Past 12 Months is Below the Poverty Level	City of Oroville			Butte County		
	2010	2019	Change	2010	2019	Change
<b>Families with female householder, no spouse present</b>	207	247	+40	2,126	2,131	+5
<b>With related children of the householder under 18 years</b>	205	247	+42	1,873	1,776	-97
<b>With related children of the householder under 5 years only</b>	81	42	-39	426	443	+17

Source: U.S. Census, 2006-2010 and 2015-2019 American Community Survey

## People with Physical Disabilities

The maps “*City of Oroville, Percent of Population with a Physical Disability, 2019*” and “*Butte County, Percent of Population with a Physical Disability, 2019*” indicate the percent of the population with a disability in the City of Oroville and Butte County. As illustrated below, 20-30% of the population in most areas of the City have a disability. In Census Tracts 25, 29, and 31 only 10-20% of the population has a disability. However, Census Tract 30.01 has the highest concentration of residents with a disability, at 30-40% of the population, which is the highest concentration of residents experiencing disability in any census tract in the County.

In comparison, 10-20% of the population has a disability in about half of the areas of Butte County, and about 20-30% of the population has a disability in the other half of Butte County (*HCD AFFH Data Resources and Mapping Tool: U.S. Census 2015-2019 American Community Survey*).

Figure 9: City of Oroville, Percent of Population with a Disability Map, 2019

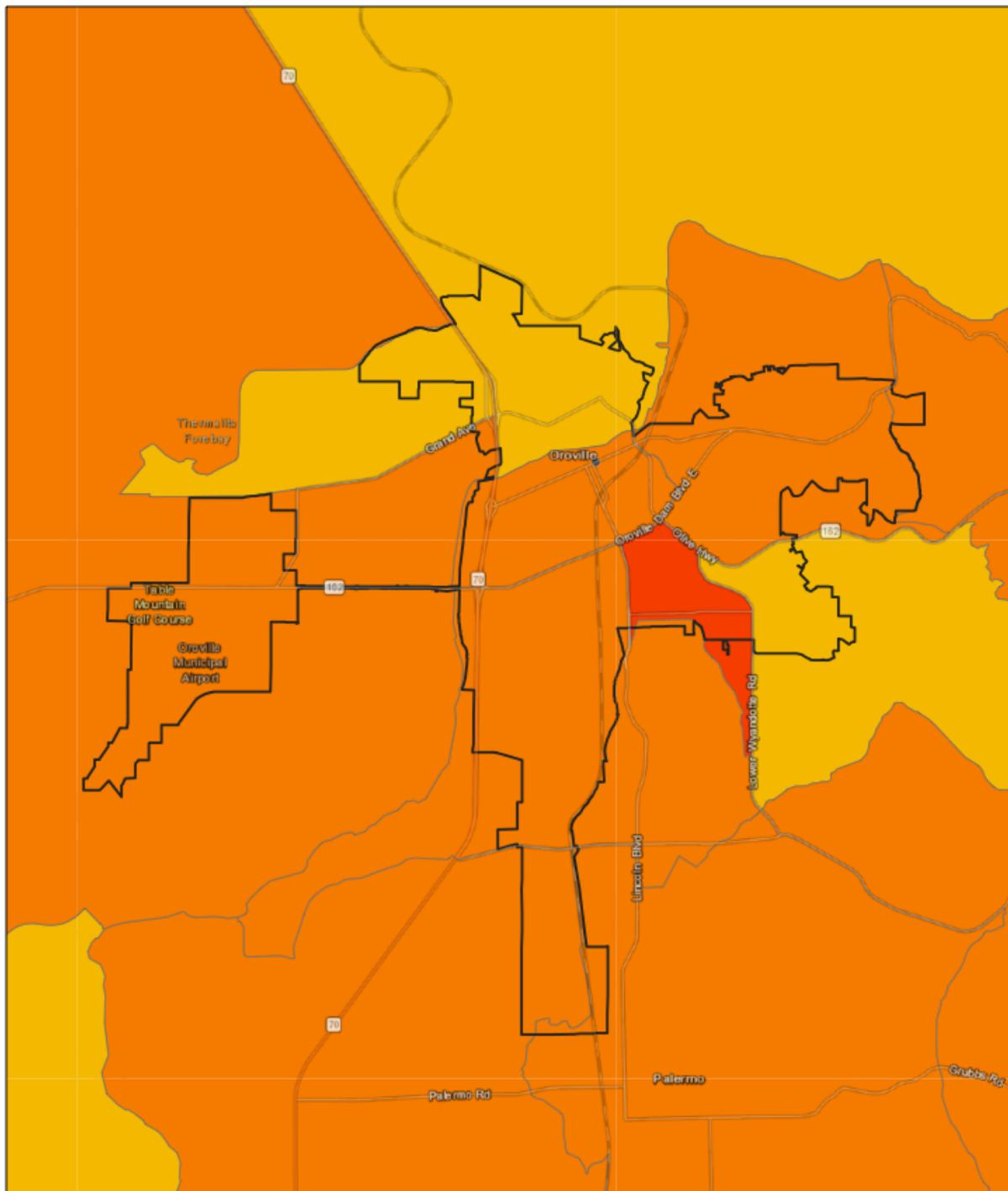

11/8/2021, 10:26:06 AM

City/Town Boundaries

(R) Population with a Disability (ACS, 2015 - 2019) - Tract

10% - 20%

20% - 30%

30% - 40%

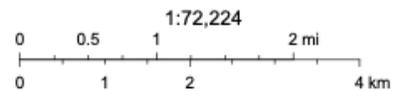
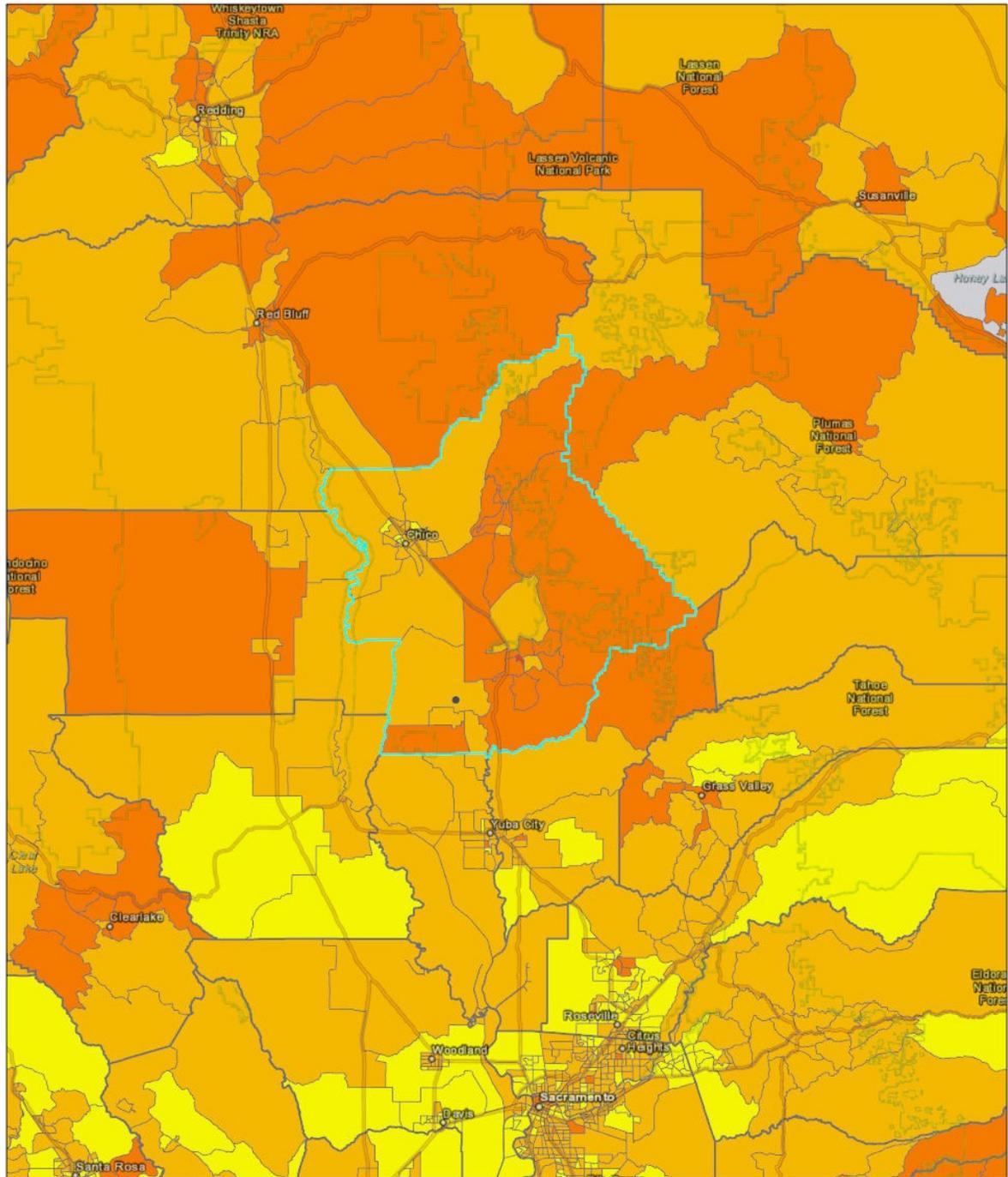

Figure 9.1: Butte County, Percent of Population with a Disability Map, 2019



10/25/2021, 10:21:39 AM

County Boundaries

(R) Population with a Disability (ACS, 2015 - 2019) - Tract

- < 10%
- 10% - 20%
- 20% - 30%
- 30% - 40%
- > 40%

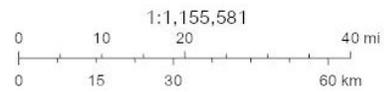

## Income Disparity

This section provides an overview of the percentage of residents experiencing poverty, the median household income, and Gini index in both the City of Oroville and Butte County.

### *Median Household Income*

The maps “*City of Oroville, Median Household Income, 2019*” and “*Butte County, Median Household Income, 2019*” depicts block group data on median household income in the City of Oroville and Butte County in 2019. The median household income in the State was \$87,110 in 2020. Areas that are light blue represent residents with the lowest median household income which includes most block groups located within Census Tract 28, 30.01, and 30.02. Residents in these areas have a median household income that is less than \$30,000, and these areas make up nearly half of the City of Oroville. Residents in Block Group 2, Census Tract 28 have the lowest median household income at \$15,179.

Areas that are medium blue represent concentrations of residents that earn between \$30,000-55,000, which includes most of the remaining areas of the City. Areas that are dark blue represent residents with the highest median household income in the City, and these areas are primarily located at the northeast end of the City, in Census Tracts 27 and 31. Residents living in Block Group 3, Census Tract 27 earn the highest median household income at \$66,083. This is still \$20,000 below the State average. The difference between areas of the highest and areas of lowest median household income is greater than \$50,000, which represents significantly large disparities in income based on residential location.

In Butte County, most block groups that have a median household income less than \$55,000 or between \$55,000 and \$87,100. Several areas have a median household income between \$87,100 and \$125,000. Households that have a median household income between \$87,100 and \$125,000 are primarily located within Chico and its surrounding areas, as well as south of Biggs, near Gridley. There are a few block groups near Chico where the median household income is greater than \$125,000, which is substantially more than the State average.

Figure 10: City of Oroville, Median household income, 2019

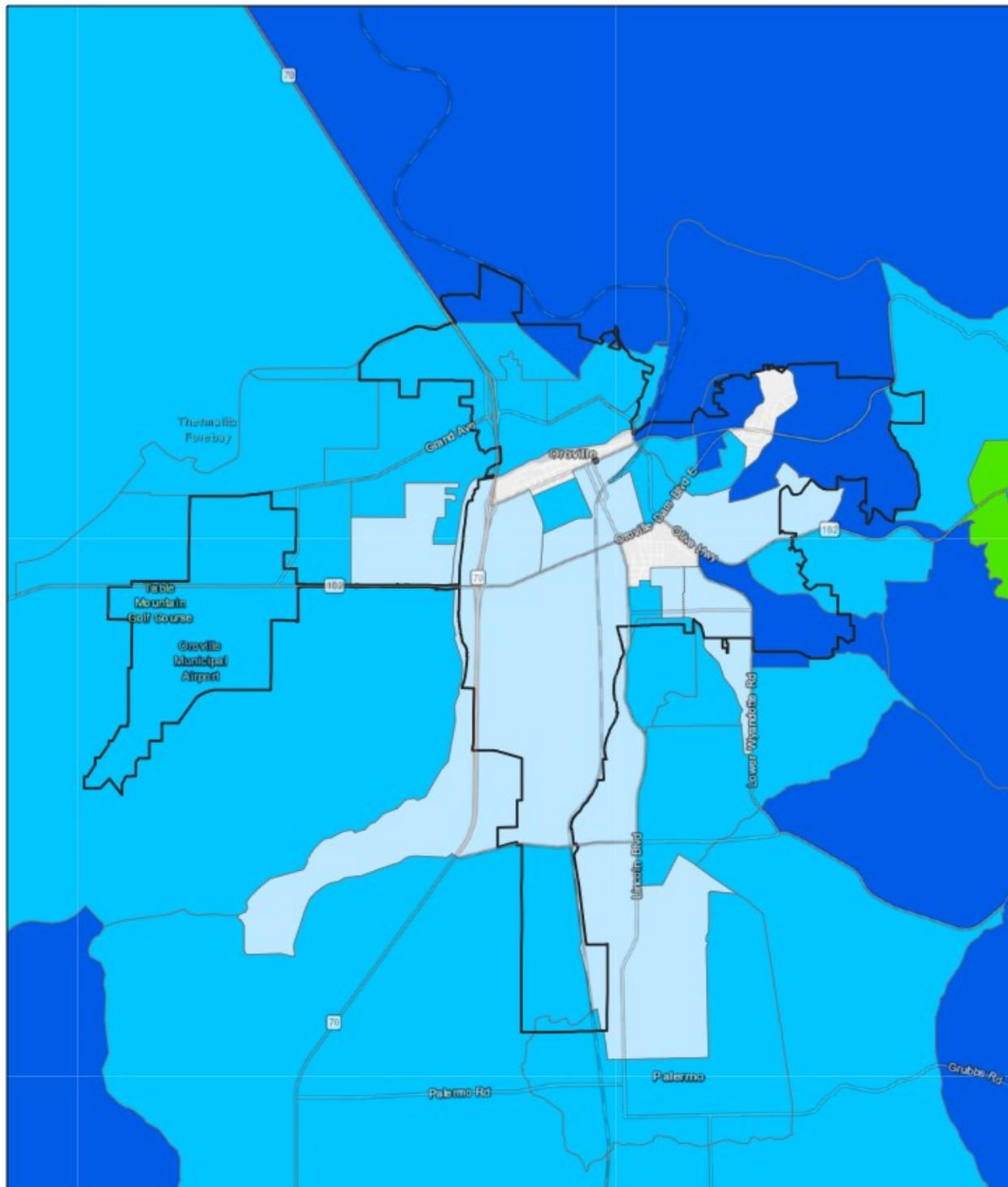

11/8/2021, 10:27:34 AM

City/Town Boundaries

(R) Median Income (ACS, 2015-2019) - Block Group

- < \$30,000
- < \$55,000
- < \$87,100 (HCD 2020 State Median Income)
- < \$125,000

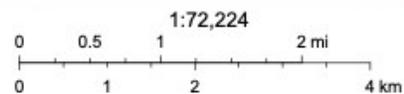
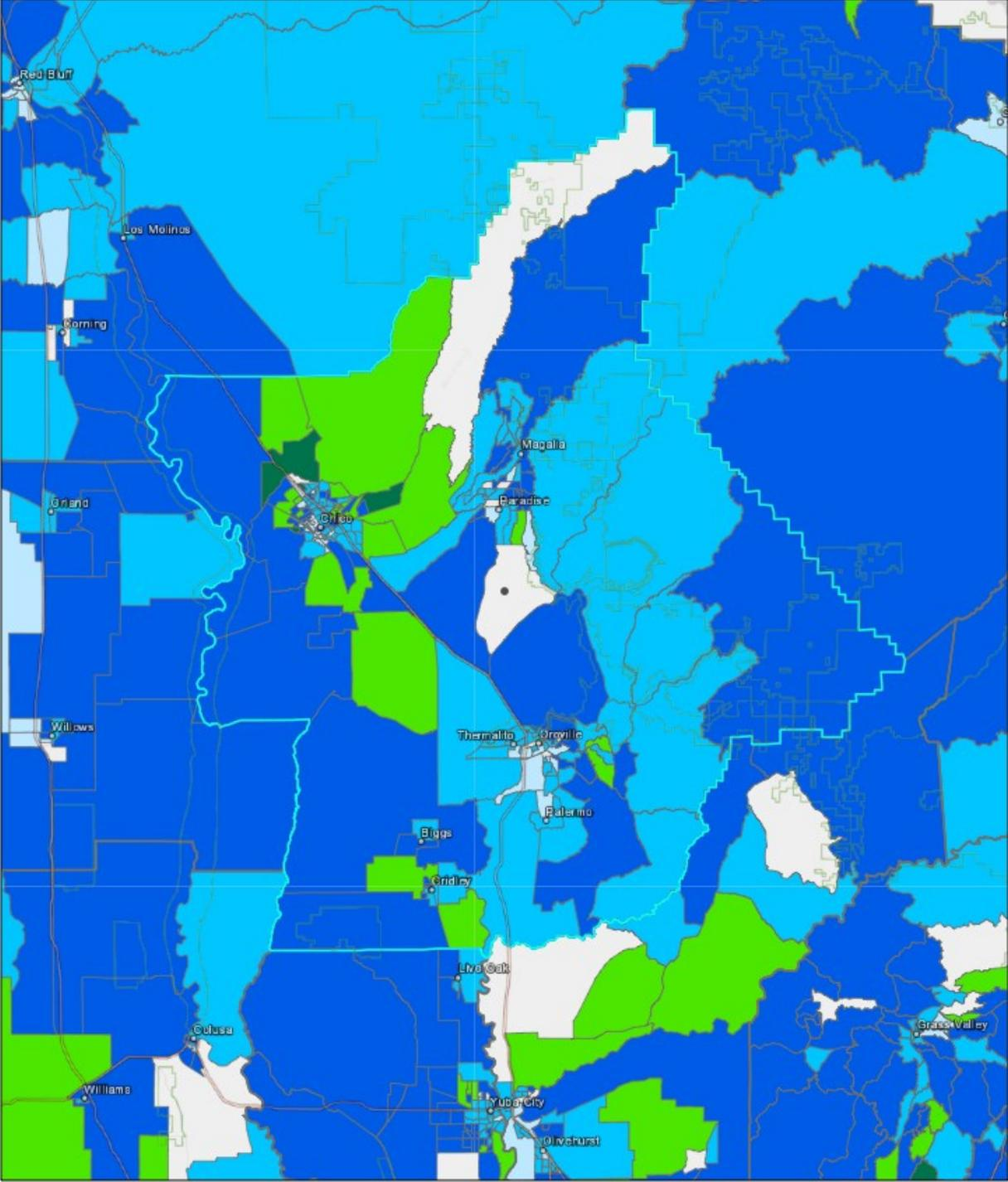

Figure 10.1: Butte County, Median household income, 2019



11/10/2021, 11:30:10 AM

County Boundaries

(R) Median Income (ACS, 2015-2019) - Block Group

- < \$30,000
- < \$55,000
- < \$87,100 (HCD 2020 State Median Income)
- < \$125,000
- Greater than \$125,000

1:577,791

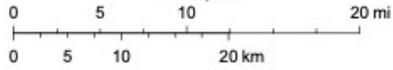

Figure 10.2: The City of Oroville, the City of Chico, and Butte County, Gini Index, 2020 illustrates the Gini index of income inequality values, which is a measure of the distribution of income across a population. A higher gini index score indicates greater income inequality, or that high-income individuals receive much larger percentages to the total income of the population. The table below indicates that Oroville has a relatively lower gini index, or relatively less income inequality than its neighboring city Chico, and less than Butte County and the State of California as a whole.

Figure 10.2: City of Oroville, City of Chico, and Butte County, Gini Index, 2020

Gini Index of Income Inequality	
Oroville	.45
Chico	.50
Butte County	.49
California	.49

Source: 2016-2020 ACS 5-Year Estimates Detailed Tables

### **Poverty Status**

The table “*City of Oroville, Butte County and the State of California, Poverty, 2012 and 2019*” compares data on individuals and families experiencing poverty for the City of Oroville, Butte County, and the State of California in 2019 compared to 2012. In this case, 2012 data was used instead of 2010 data because it was the oldest dataset available.

The percent of families experiencing poverty in Oroville is significantly greater than that of the State of California as a whole: 25.5% compared to 13.4%. The percent of individuals experiencing poverty in Oroville is also greater than the State of California as a whole: 17.2% compared to 9.6%. These values are also significantly greater than Butte County. Individuals and families residing in Butte County are significantly more likely to experience poverty than in the State of California.

The percent of both families and individuals experiencing poverty decreased for Butte County and the State of California by an average of almost 2% in 2019 compared to 2012. However, those values increased for the City of Oroville by 5.4% and 0.5%, respectively. There are significantly more individuals and families in poverty in the City of Oroville and Butte County than the State of California

Figure 10.3: City of Oroville, Butte County, and State of California, Poverty, 2012 and 2019

Jurisdiction	Measure of Poverty	2012		2019		2012-2019 Change
		Percent	Estimated Number	Percent	Estimated Number	
City of Oroville	Families whose income in the past 12 months is below the poverty level	11.8%	321	17.2%	541	+5.4%
	Individuals whose income in the past 12 months is below the poverty level	25%	3,668	25.5%	4,538	+0.5%
Butte County	Families whose income in the past 12 months is below the poverty level	12.9%	6,707	11.1%	5,711	-1.8%
	Individuals whose income in the past 12 months is below the poverty level	20.6%	44,156	19.1%	41,974	-1.5%
State of California	Families whose income in the past 12 months is below the poverty level	11.5%	983,254	9.6%	860,010	-1.9%
	Individuals whose income in the past 12 months is below the poverty level	15.3%	5,590,100	13.4%	5,149,742	-1.9%

Source: U.S. Census, 2008-2012 and 2015-2019 American Community Survey

The map “City of Oroville, Poverty Status, 2019” depicts the geographic distribution of poverty in the City of Oroville in 2019. For this analysis, census tract data is used because block group data is not available. Approximately 30-40% of the population is living below the poverty level in Census Tracts 28, 30.01, 30.02, and 37, which is greater than most areas of Butte County. In contrast, less than 10% of the population is living below the poverty level in Census Tract 31, and 10-20% of the population is living below the poverty level in Census Tracts 27 and 29. In Census Tract 25, 20-30% of the population is living below the poverty level.

Figure 10.4: City of Oroville, Poverty Status, 2019

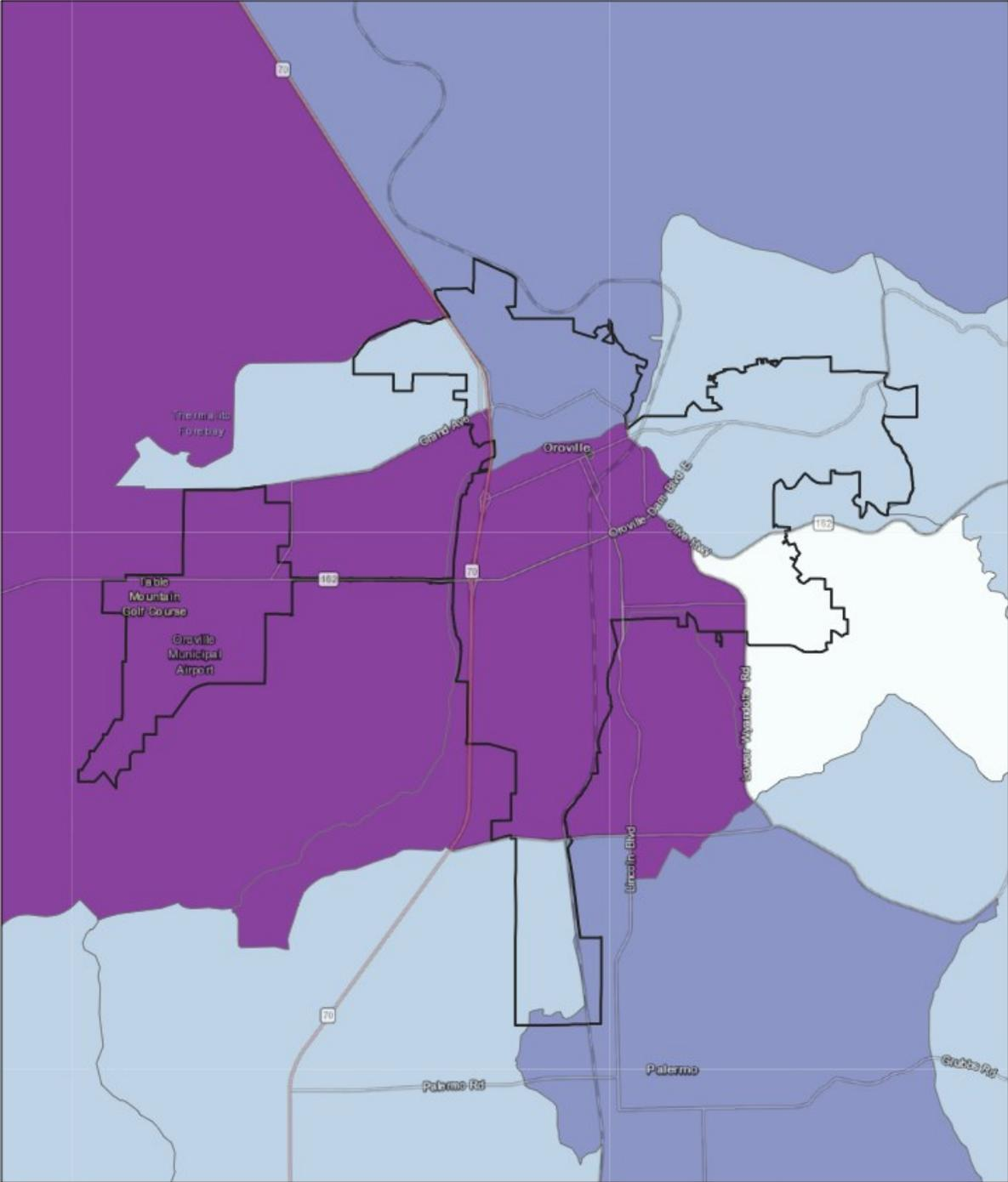

11/8/2021, 10:27:17 AM

City/Town Boundaries

(R) Poverty Status (ACS, 2015 - 2019) - Tract

- < 10%
- 10% - 20%
- 20% - 30%
- 30% - 40%

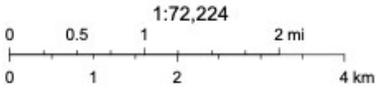

## *Data and Knowledge from Local Stakeholders*

Local data and knowledge is collected through interviews with regional stakeholders whose service areas include the City of Oroville.

### *Disability Action Center*

On September 13, 2021, the authors received a written response to interview questions from a staff member at the Disability Action Center (DAC) located in Chico. DAC is a non-profit, Chico-based organization that provides free support to assist community members in Northern California who have disabilities to achieve their optimal level of self-reliance. DAC serves Butte, Colusa, Glenn, Lassen, Modoc, Plumas, Shasta, Siskiyou, and Tehama Counties. DAC accomplishes this mission thorough provision of informational services, housing assistance, and provider referrals.

Staff noted that the tri-county region of Butte, Tehama, and Glenn County lacks affordable and permanent housing. Low-income residents experience barriers to accessing housing due to poor credit, poor rental histories, income requirements, and felony records. In addition, low-income residents can benefit from robust services and programs to complement housing, such as childcare and educational programs. There are a significant number of single parent female-headed households in the region who may not have the time or resources to access daycare or service programs. Some residents who are transitioning from homelessness to long-term housing may lack knowledge regarding responsible tenant practices and expectations.

Staff commented that Butte County has a significant population of residents who are experiencing homelessness. Many are unsheltered and cannot access shelter services because they are not allowed to bring companion animals, which provide support and companionship. In addition, residents who are experiencing unsheltered homelessness do not have access to reliable transportation, food programs, a community kitchen, showers, laundry facilities, internet, electricity, or a place to receive mail. Many are survivors of recent fires, especially senior women who have not been able to reconstruct their life, due to lack of identification documentation and the loss of naturally affordable housing in the region. Regions of the burn scars in the town of Paradise and community of Berry Creek still lack power and infrastructure required to build new housing. Survivors are living in temporary shelters or vehicles while searching for permanent housing options. These communities are located approximately 20 miles from the City of Oroville.

Despite these factors, addressing homelessness and affordable housing shortages is a contentious issue in the community. Staff believes that local, State, and Federal administrative support in zoning and development application fees could incentivize low-income housing developments.

### ***Stonewall Alliance Center***

On August 4, 2021, authors conducted an online interview over Zoom with a staff member that works at Stonewall Alliance Center (SAC) and Safe Space Winter Shelter (SSWS). SAC is a nonprofit agency based in Chico that serves the Northern Sacramento Valley lesbian, gay, bisexual, transgender\*, and queer (LGBTQ+) community by providing support, resources, advocacy, and education. SSWS is a non-profit agency based in Chico that provides low-barrier emergency shelter from December to March for people experiencing homelessness, primarily those with severe mental health conditions.

Staff reported that there are few rental vacancies and a lack of assisted living facilities for residents with severe mental health conditions, substance use disorder, or those experiencing homelessness. Staff noted a need to increase awareness around the factors that contribute to or perpetuate homelessness such as housing shortages, job insecurities, mental health conditions, and drug or substance use issues.

Staff reported that the local LGBTQ+ community faces barriers to accessing housing and homelessness services. LGBTQ+ residents, including the staff member interviewed, felt like they had to hide their identity to avoid harassment from a landlord or roommates. In both Glenn and Butte Counties, staff reported it is common for young, trans people of color to get kicked out of their house and experience homelessness. There are no publicly accessible shower or laundry services in the region. During the COVID-19 pandemic, many public gathering spaces that provided electricity and public water fountains were shut off for health and safety. This made it difficult for residents experiencing homelessness to access services that are increasingly provided online.

There are several faith-based shelters in the region, including the Oroville Rescue Mission and the Jesus Center, but no trans or LGBTQ+ friendly shelters in Butte or Glenn County. The LGBTQ+ community in Butte County often experiences harassment or denial of services due to their sexual orientation. Couples also face barriers due to dormitory sleeping policies that do not allow them to sleep together. In addition, for community members who are employed, it may be challenging to access shelters who close evening intake at 6:00 pm. Drug testing requirements and ownership of companion animals can also be barriers to accessing shelter services.

### ***Summary of Findings***

The City's total population size grew by more than 25% in 2019 compared to 2010, which is an exponential increase in population size. The majority of the population in the City identifies as White, but diversity has increased substantially. The City experienced large increases in its minority population. A significantly large number of residents identify as Asian, and that number is increasing. Only 13.6% of the population identifies as Hispanic/Latino. About 1,200 individuals are not fluent in English.

Census Tract 30.02 has one of the lowest concentrations of children residing in married coupled households in the County, at 20-40% of households. Census Tract 31 has the highest concentration of children residing in married couple households at greater than 80% of households. Approximately 20-

40% of children reside in households headed by single mothers in Census Tracts 28, 30.01, 30.02, and 37, which is significantly greater than most other areas in the County. In 2019, 247 single mother households were living in poverty. In most areas of the City, 20-30% of the population is living with a disability. Census Tract 30.01 has the highest concentration of residents with a disability, at 30-40% of the population, which is greater than any other census tract in the County.

Residents in Census Tracts 28, 30.01, and 30.02 have the lowest median household income, which is less than \$30,000 on average. These areas make up nearly half of the City of Oroville. Census Tract 27 and 31 have the highest median household income. The difference between areas of the highest and areas of lowest median household income is greater than \$50,000, which represents significantly large disparities in income based on residential location. The Gini index of income inequality indicates that this income disparity is slightly less than the state level of income disparity. One in four families is experiencing poverty in the City of Oroville. Approximately 30-40% of the population is living below the poverty level in Census Tracts 28, 30.01, 30.02, and 37, which is greater than most areas of Butte County. In contrast, less than 10% of the population is living below the poverty level in Census Tract 31, and 10-20% of the population is living below the poverty level in Census Tracts 27 and 29. These findings indicate that low-income residents, residents with a disability, and single parent households are concentrated in Census Tracts 28, 30.01, 30.02, and 37. Affluent resident and married-couple households are concentrated in Census Tract 27 and 31. These census tracts also have the least amount of single mother households and residents who are experiencing poverty.

Staff at the Stonewall Alliance Center noted there is a lack of assisted living facilities for residents with severe mental health conditions, substance abuse disorders, and individuals experiencing homelessness. Residents who identify as LGBTQ+ may face harassment from landlords or denial of shelter services due to their orientation. Staff at Disability Action Center indicated that the tri-county region lacks affordable housing and permanent supportive housing. Many low-income residents face barriers acquiring housing due to poor credit, poor rental histories, income requirements, and felony records. Single mothers, senior women, and residents who are precariously housed could benefit from robust services and programs to complement housing.

### **C. RACIALLY AND ETHNICALLY CONCENTRATED AREAS OF POVERTY (R/ECAP)**

---

The third section of the Assessment of Fair Housing addresses racially and ethnically concentrated areas of poverty (R/ECAP).

#### ***Local and Regional Patterns and Trends***

This section includes data tables, narratives, and maps to illustrate local and regional patterns and trends regarding racially and ethnically concentrated areas of poverty. For the purposes of this analysis, racially and ethnically concentrated areas of poverty include R/ECAP areas, areas of high segregation and poverty, and racial or ethnic concentrations of people of color or people who identify as White.

**R/ECAP Areas**

The map “*Butte County, R/ECAP, 2020*” depicts block group data on racially or ethnically concentrated areas of poverty, which are areas 50 percent or more of the population is nonwhite and 40 percent or of people are living below the poverty threshold. Areas outlined in red experience high levels of racial or ethnic concentrations of poverty. As depicted below, the Butte County does not have any of these areas.

Figure 11: Butte County, R/ECAP Areas, 2020

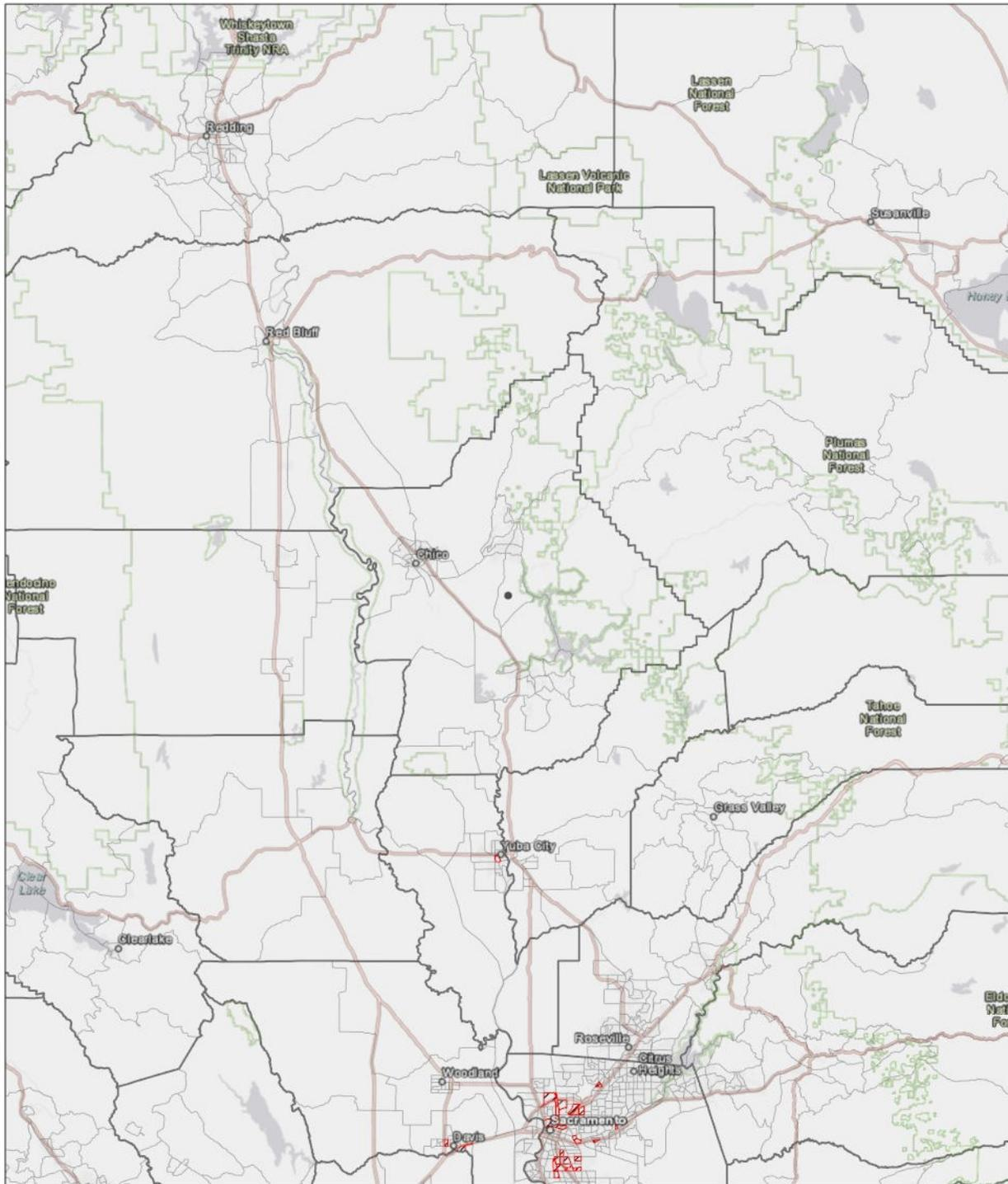

10/25/2021, 11:01:16 AM

County Boundaries

(R) Racially or Ethnically Concentrated Areas of Poverty "R/ECAP'S" (HUD, 2009 - 2013) - Tract

0 - Not a R/ECAP

1 - R/ECAP

1:1,155,581

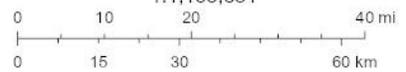

## Racially Concentrated Areas of Affluence

Racially Concentrated Areas of Affluence (RCAA) are areas that have a high proportion of white, affluent residents and a low proportion of people of color and low-income residents. RCAAs tend to have better access to resources such as schools, jobs, healthcare, and higher property values. Because all areas of the City of Oroville have a median income lower than the State's average, there are no racially concentrated areas of affluence.

## Tax Credit Allocation Committee (TCAC) Areas

The Department of Housing and Community Development and the California Tax Credit Allocation Committee created a group of organizations and researchers called the California Fair Housing Task Force to identify areas in every region that have been shown by research to support positive economic, educational, and health outcomes for children as well as areas that experience high segregation and poverty. Areas outlined in red meet standards for poverty and racial segregation, in which 30% or more of the population is below the poverty line and there is an overrepresentation of people of color relative to the county within that block group. The City of Oroville has several block groups that experience high segregation and poverty, which are in Census Tracts 25, 28, 30.01, and 30.02, and 37.

Figure 12: City of Oroville, Areas of High Segregation and Poverty Map, 2020

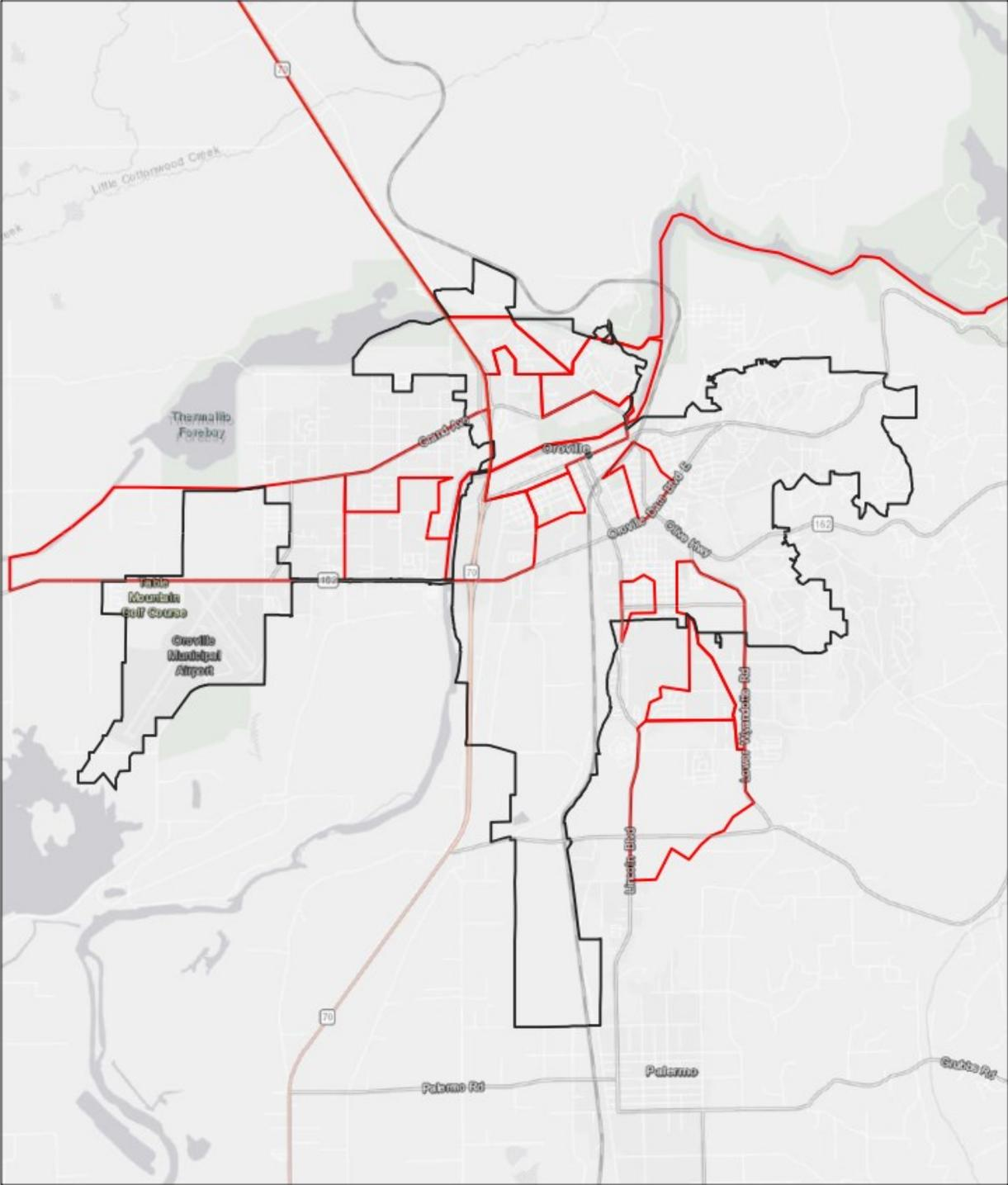

11/8/2021, 10:37:02 AM

- City/Town Boundaries
- (R) TCAC Area of High Segregation and Poverty (2021) - Tract

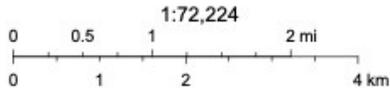

## Summary of Findings

The findings indicate that there are no R/ECAP areas, however, there are several areas within the City that experience high levels of segregation and poverty. These areas are primarily located in Census Tracts 25, 28, 30.01, and 30.02, and 37. Census Tracts 25, 29, 30.01, 30.02, and 33 experienced the largest increases in diversity in 2019 compared to 2010. These findings suggest that Census Tracts 25, 30.01, and 30.02 are areas in which concentrations of diversity and poverty is substantially growing. There are no racially concentrated areas of affluence.

## D. DISPARITIES IN ACCESS TO OPPORTUNITY

---

The fourth section of the Assessment of Fair Housing addresses disparities in access to opportunity. “Access to opportunity is a concept to approximate place-based characteristics linked to critical life outcomes. Access to opportunity oftentimes means both improving the quality of life for residents of low-income communities, as well as supporting mobility and access to ‘high resource’ neighborhoods” (*California State Department of Housing and Community Development, Affirmatively Furthering Fair Housing, 2021*).

### *Local and Regional Patterns and Trends*

This section includes data tables, narratives, and maps to illustrate local and regional patterns and trends regarding disparities in access to opportunity. For the purposes of this analysis, disparities in access to opportunity include economic opportunity scores, environmental scores, educational opportunity, proximity to jobs, commuting patterns, and occupational data.

### **Access to Opportunity**

The California Fair Housing Task Force created an opportunity map to identify regions whose characteristics have been shown by research to support positive economic, educational, and health outcomes for low-income families, particularly long-term outcomes for children. The maps below provides composite scores for each block group as well as economic scores, education scores, and environmental scores.

#### ***Access to Opportunity, Composite Score***

The map, “*City of Oroville, Access to Opportunity, 2021*” depicts block group level data on disparity in access to opportunity in the City of Oroville.

The map indicates that most areas in the City of Oroville are low resource areas or areas of high segregation and poverty, as mentioned earlier. Several areas have missing or insufficient data.

Block Group 6, located at the northeast end of the City in Census Tract 27, is considered a moderate resource area.

In comparison, Chico and northern parts of Butte County are considered high and highest resources areas, eastern parts of the County are low resource areas, and western parts of the County are moderate resource areas. In comparison to Butte County, the City of Oroville is an area with significantly fewer resources.

Figure 13: City of Oroville, Access to Opportunity Map, 2021

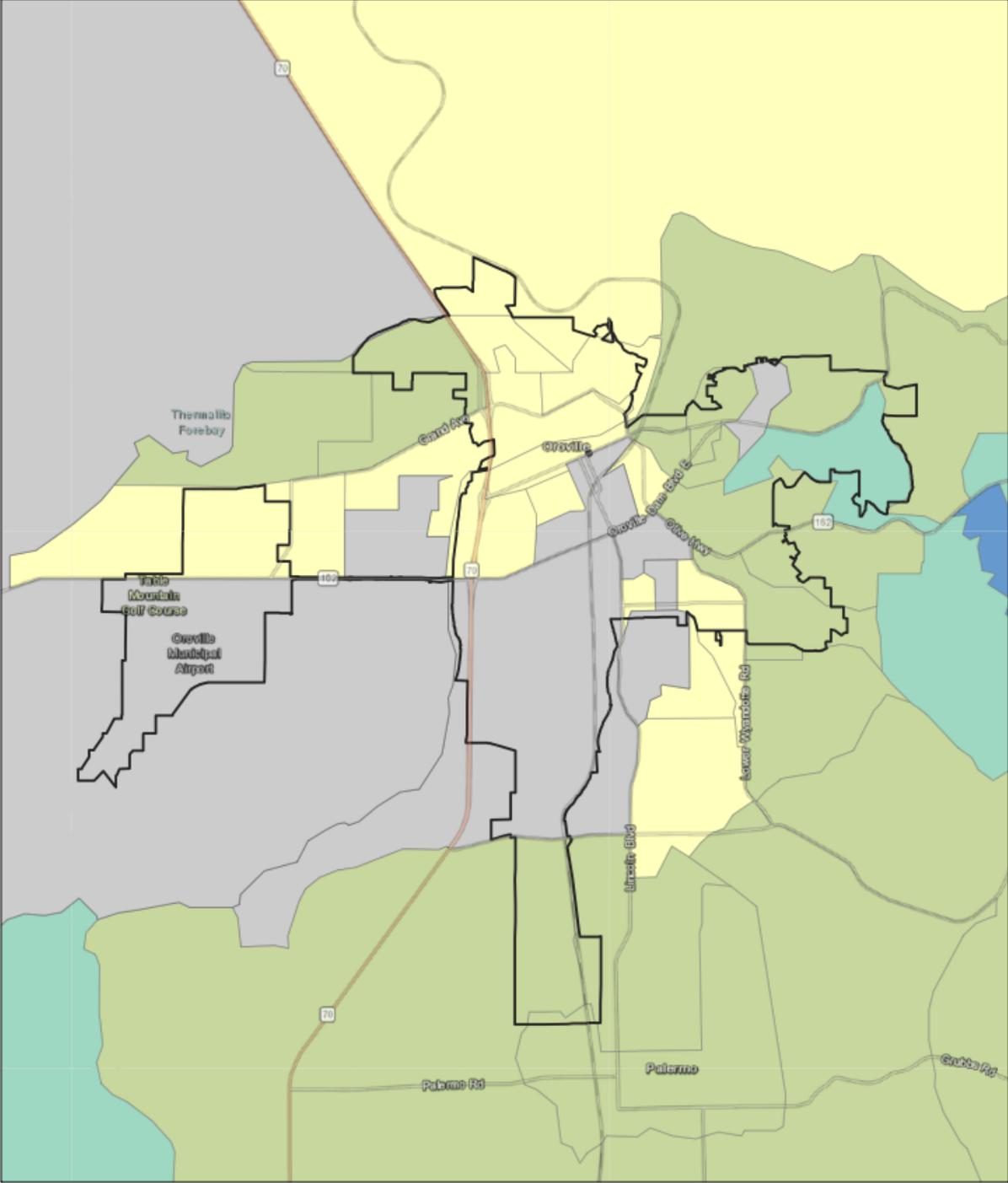

11/8/2021, 10:34:37 AM

City/Town Boundaries

(R) TCAC Opportunity Areas (2021) - Composite Score - Tract

- High Resource
- Moderate Resource
- Low Resource
- High Segregation & Poverty
- Missing/Insufficient Data

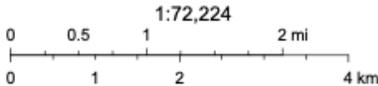
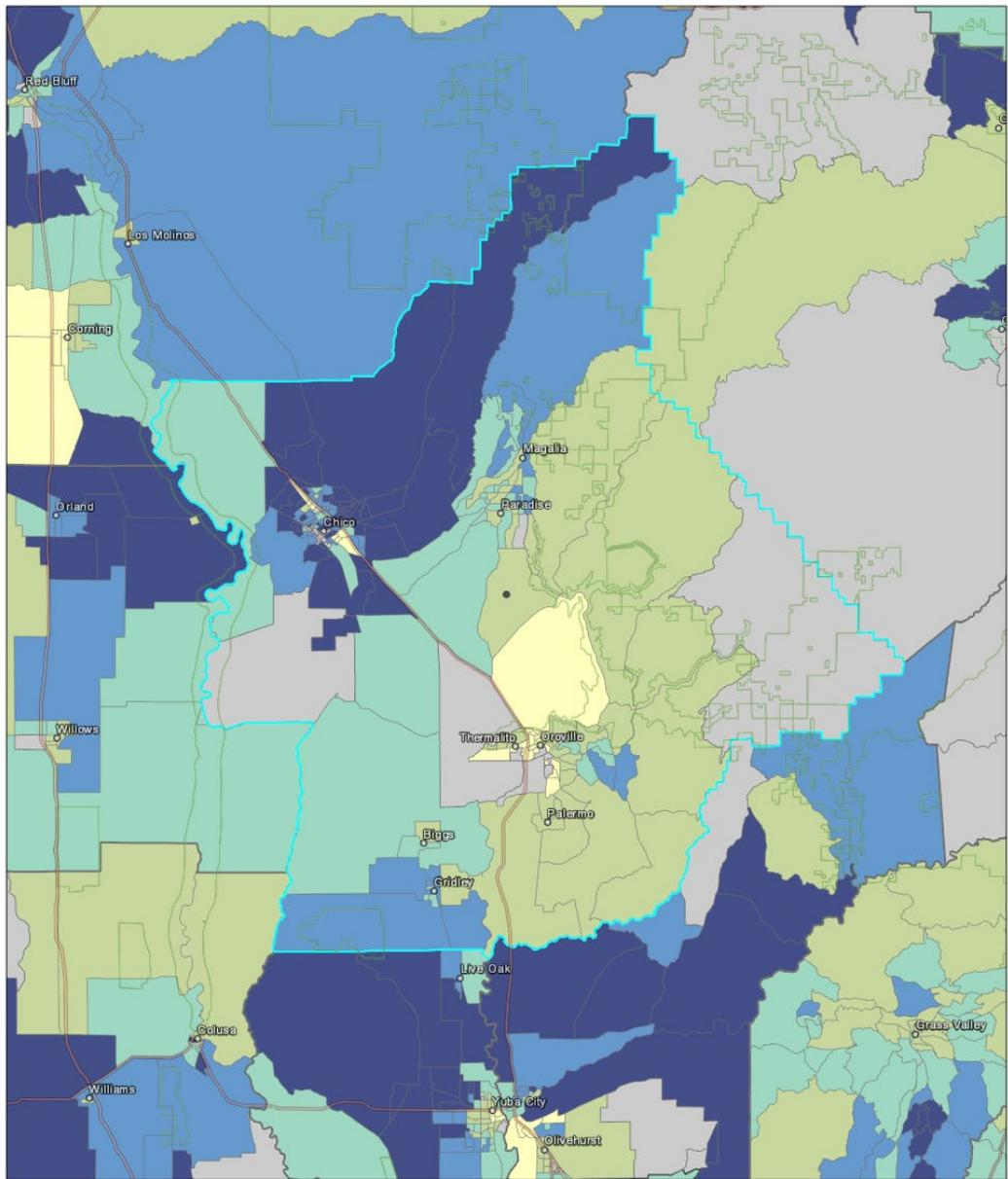

Figure 13.1: Butte County, Access to Opportunity Map, 2021



10/25/2021, 12:29:47 PM

County Boundaries

(R) TCAC Opportunity Areas (2021) - Composite Score - Tract

- Highest Resource
- High Resource
- Moderate Resource (Rapidly Changing)
- Moderate Resource
- Low Resource
- High Segregation & Poverty
- Missing/Insufficient Data

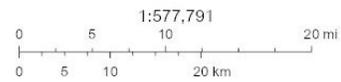

Esri, HERE, Garmin, © OpenStreetMap contributors, and the GIS

### ***Access to Economic Opportunity***

The map, “*City of Oroville, Economic Opportunity, 2021*” depicts block group level data on disparity in access to economic opportunity in the City of Oroville. The map indicates that residents in most parts of the City experience the least positive economic outcome, except for a few areas in Census Tract 27 and 29, where economic outcomes are slightly more positive. Block Group 6 located in Census Tract 27 has the most positive economic outcome in the entire City.

The map, “*Butte County, Access to Economic Opportunity, 2021*” depicts census tract level data in Butte county based on economic scores. Generally, the northwest portion of the county around Chico is identified as “more positive economic outcome” and the east and south portions of the county near Biggs, Gridley, Magalia, Oroville, and Paradise are identified as “less positive economic outcome” (*HCD AFFH Data Resources and Mapping Tool: 2021 TCAC*).

Economic scores are calculated by data indicators of poverty, adult education, employment, job proximity, and median home value found in the U.S. Census 2014-2018 American Community Survey and the U.S. Census 2017 Longitudinal Employer-Household Dynamics. Scores based on these indicators range from less positive economic outcome to more positive economic outcome. How data indicators are measured is detailed below (*California Fair Housing Task Force, 2021 TCAC/HCD Opportunity Map Methodology, December 2020*).

- **Poverty:** Percent of population with income above 200% of federal poverty line
- **Adult education:** Percent of adults with a bachelor’s degree or above
- **Employment:** Percent of adults aged 20-64 who are employed in the civilian labor force or in the armed forces
- **Job proximity:** Number of jobs filled by workers with less than a bachelor’s degree that fall within a given radius (determined by the typical commute distance of low-wage workers in each region) of each census tract population-weighted centroid
- **Median home value:** Value of owner-occupied homes

Figure 13.2: City of Oroville, Access to Economic Opportunity Map, 2021

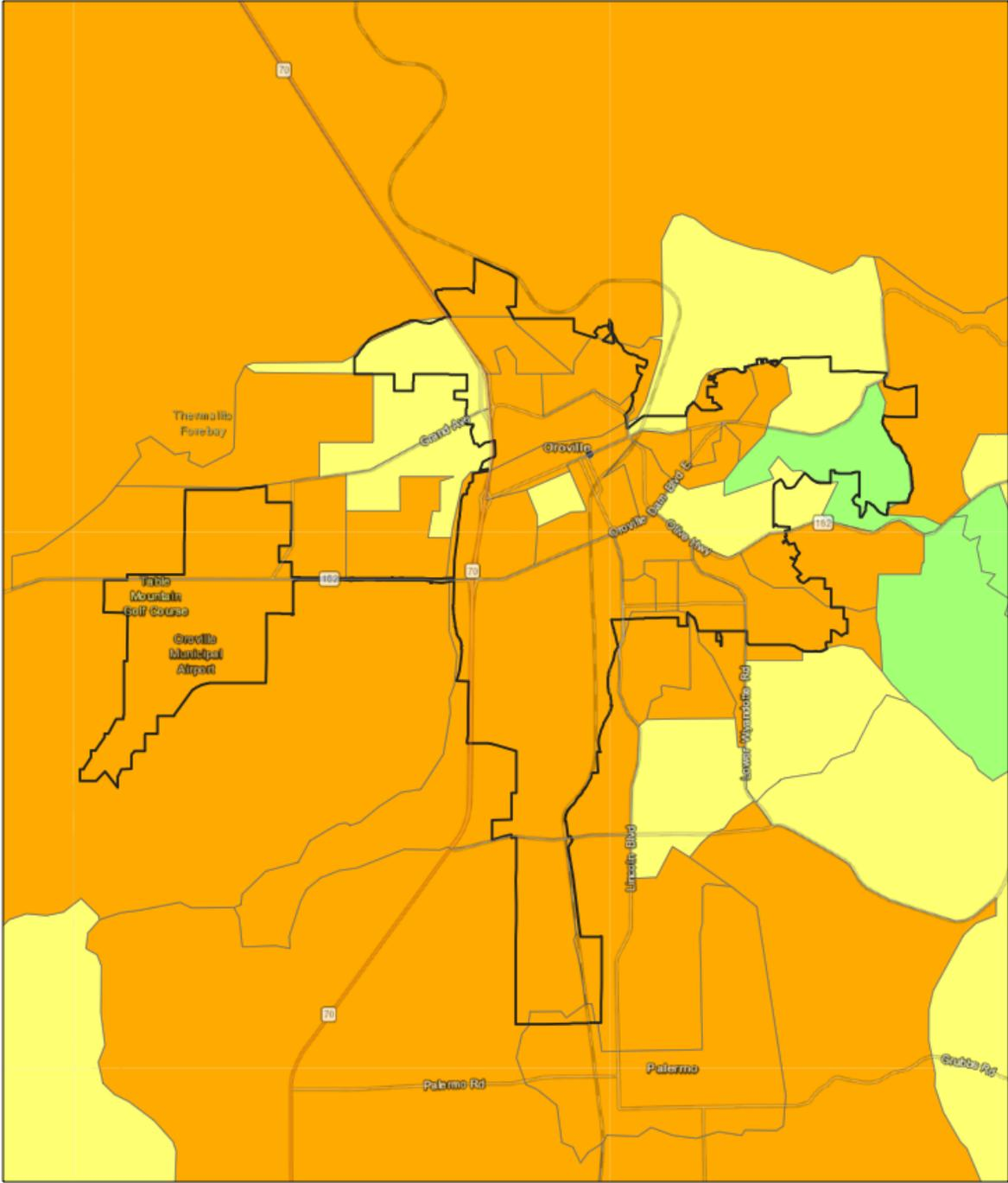

11/8/2021, 10:34:50 AM

City/Town Boundaries

(R) TCAC Opportunity Areas (2021) - Economic Score - Tract

< 0.25 (Less Positive Economic Outcome)

0.25 - 0.50

0.50 - 0.75

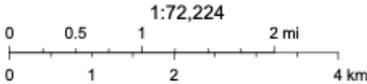
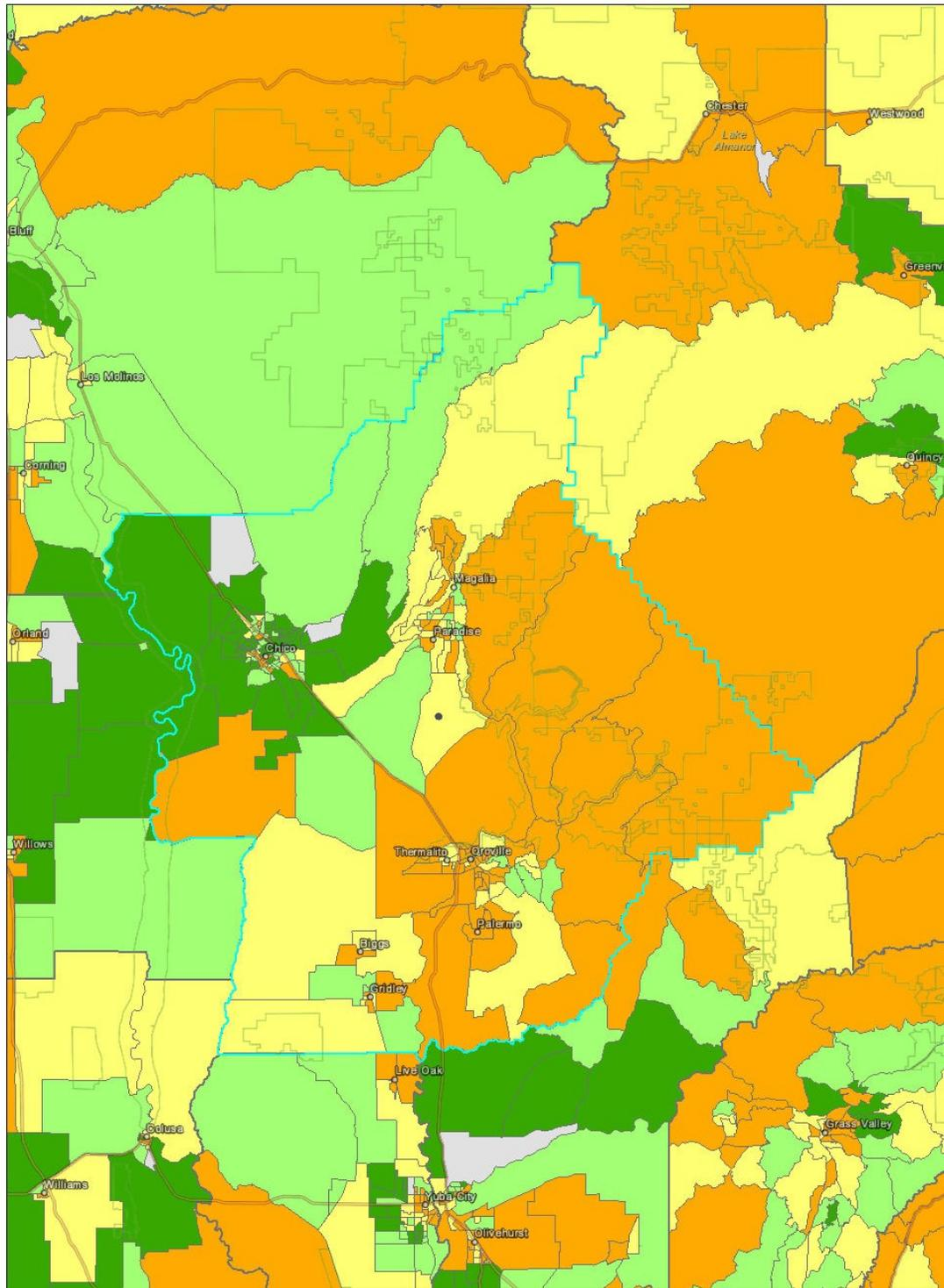
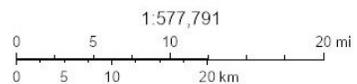

Figure 13.3: Butte County, Access to Economic Opportunity Map, 2021



3/28/2022, 3:03:46 PM

- County Boundaries
- (R) TCAC Opportunity Areas (2021) - Economic Score - Tract
  - < 0.25 (Less Positive Economic Outcome)
  - 0.25 - 0.50
  - 0.50 - 0.75
  - > 0.75 (More Positive Economic Outcome)
  - No Data



Esri, HERE, Garmin, (c) OpenStreetMap contributors, and the GIS user community  
Esri, HERE, Garmin, © OpenStreetMap contributors, and the GIS user community

CAHCD

### ***Access to Environmental Opportunity***

The map, “*City of Oroville, Environmental Score, 2021*” depicts block group level data on disparity in environmental scores in the City of Oroville. The map indicates that residents in Census Tract 25, 27, 29, and 31 experience the most positive environmental outcomes in the City. Residents in Census Tracts 30.01, 20.02, 33, and 37 experience the least positive environmental outcomes.

The map, “*Butte County, Environmental Score, 2021*” depicts census tract level data in Butte county based on environmental scores. Generally, the portions of the county that are more mountainous and less populated are identified as having “more positive environmental outcomes.” These areas are located east of Chico, north of Magalia, and east of Magalia, Paradise, and Oroville. North and west county around Chico and between Chico and Oroville are identified as having “less positive environmental outcomes.” The very east corner of the county is also identified as having “less positive environmental outcomes” (*HCD AFFH Data Resources and Mapping Tool: 2021 TCAC*).

Environmental scores are calculated by data indicators of pollution, exposures, and environmental effect from CalEnviroScreen 3.0. Scores based on these indicators range from less positive environmental outcomes to more positive environmental outcomes. How data indicators are measured is detailed below (*California Fair Housing Task Force, 2021 TCAC/HCD Opportunity Map Methodology, December 2020*).

- CalEnviroScreen 3.0: Variables include Ozone, PM2.5, Diesel PM, Drinking Water, Pesticides, Tox. Release, Traffic, Cleanup Sites, Groundwater Threats, Hazardous Waste, Impaired Water Bodies, and Solid Waste Sites

Figure 13.4: City of Oroville, Environmental Score, 2021

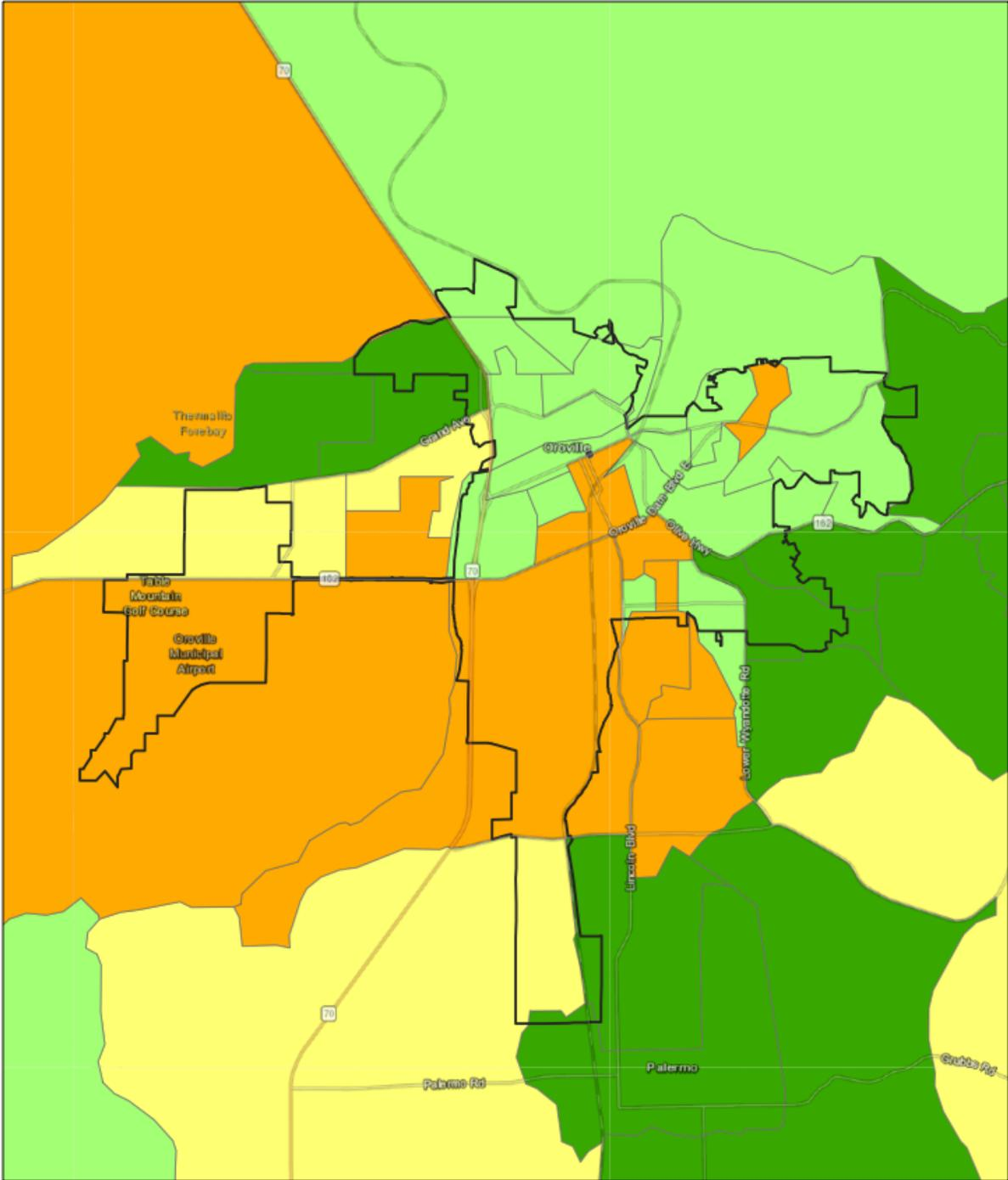

11/8/2021, 10:35:19 AM

City/Town Boundaries

(R) TCAC Opportunity Areas (2021) - Environmental Score -Tract

- < .25 (Less Positive Environmental Outcomes)
- .25 - .50
- .50 - .75
- .75 - 1 (More Positive Environmental Outcomes)

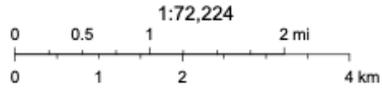
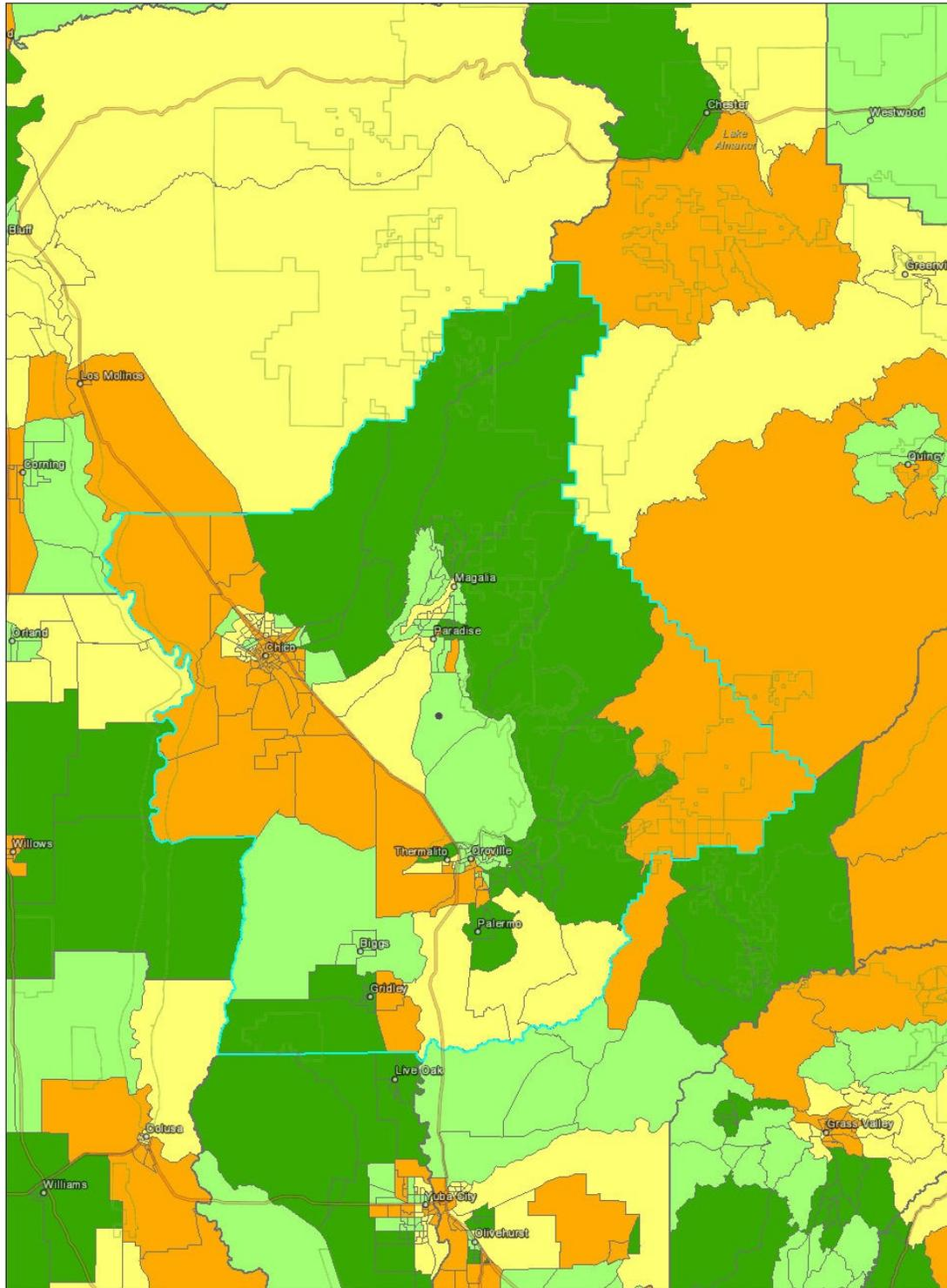
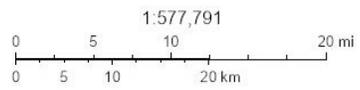

Figure 13.5: Butte County, Environmental Score, 2021



3/28/2022, 3:05:17 PM

-  County Boundaries
- (R) TCAC Opportunity Areas (2021) - Environmental Score -Tract
-  < .25 (Less Positive Environmental Outcomes)
-  .25 - .50
-  .50 - .75
-  .75 - 1 (More Positive Environmental Outcomes)



Esri, HERE, Garmin, (c) OpenStreetMap contributors, and the GIS user community  
Esri, HERE, Garmin, © OpenStreetMap contributors, and the GIS user community

CAHCD

### ***Access to Educational Opportunity***

The map, “*City of Oroville, Educational Opportunity, 2021*” depicts block group level data on disparity in access to educational opportunity in the City of Oroville. The map indicates that residents in all of the census tracts that encompass the City experience the least positive education outcomes, except residents residing in Census Tract 33. Residents in this part of the City experience slightly more positive education outcomes.

The map, “*Butte County, Educational Opportunity, 2021*” depicts census tract level data in Butte county based on education scores. Generally, the north portions of the county around Chico, and between Chico and Magalia including the communities of Butte Creek Canyon, Cohasset, and Forest Ranch (not listed on map), are identified as “more positive education outcome.” The east and south portions of the county near Oroville, Palermo, and Thermalito, and between Oroville and Paradise, are identified as “less positive education outcome” (*HCD AFFH Data Resources and Mapping Tool: 2021 TCAC*).

Education scores are calculated by data indicators of math proficiency, reading proficiency, high school graduation rates, and student poverty rate from the 2018-2019 California Department of Education. Scores based on these indicators range from less positive education outcomes to more positive education outcomes. How data indicators are measured is detailed below (*California Fair Housing Task Force, 2021 TCAC/HCD Opportunity Map Methodology, December 2020*).

- **Math proficiency:** Percentage of 4th graders who meet or exceed math proficiency standards
- **Reading proficiency:** Percentage of 4th graders who meet or exceed literacy standards
- **High school graduation rates:** Percentage of high school cohort that graduated on time
- **Student poverty rate:** Percent of students not receiving free or reduced-price lunch

Figure 13.6: City of Oroville, Educational Opportunity, 2021

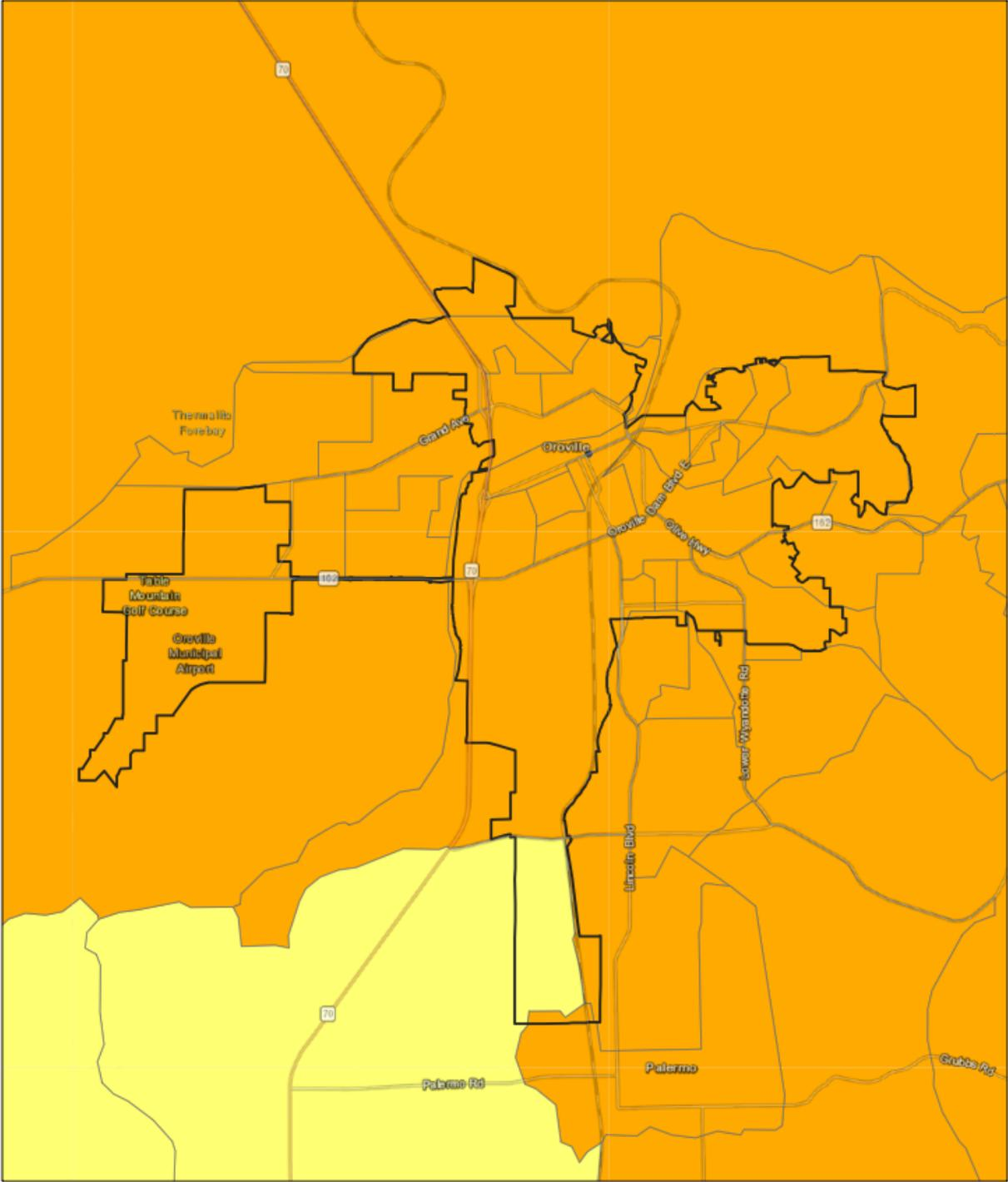

11/8/2021, 10:35:00 AM

City/Town Boundaries

(R) TCAC Opportunity Areas (2021) - Education Score -Tract

< 0.25 (Less Positive Education Outcomes)

0.25 - 0.50

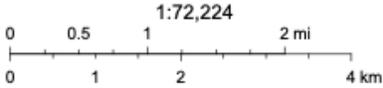
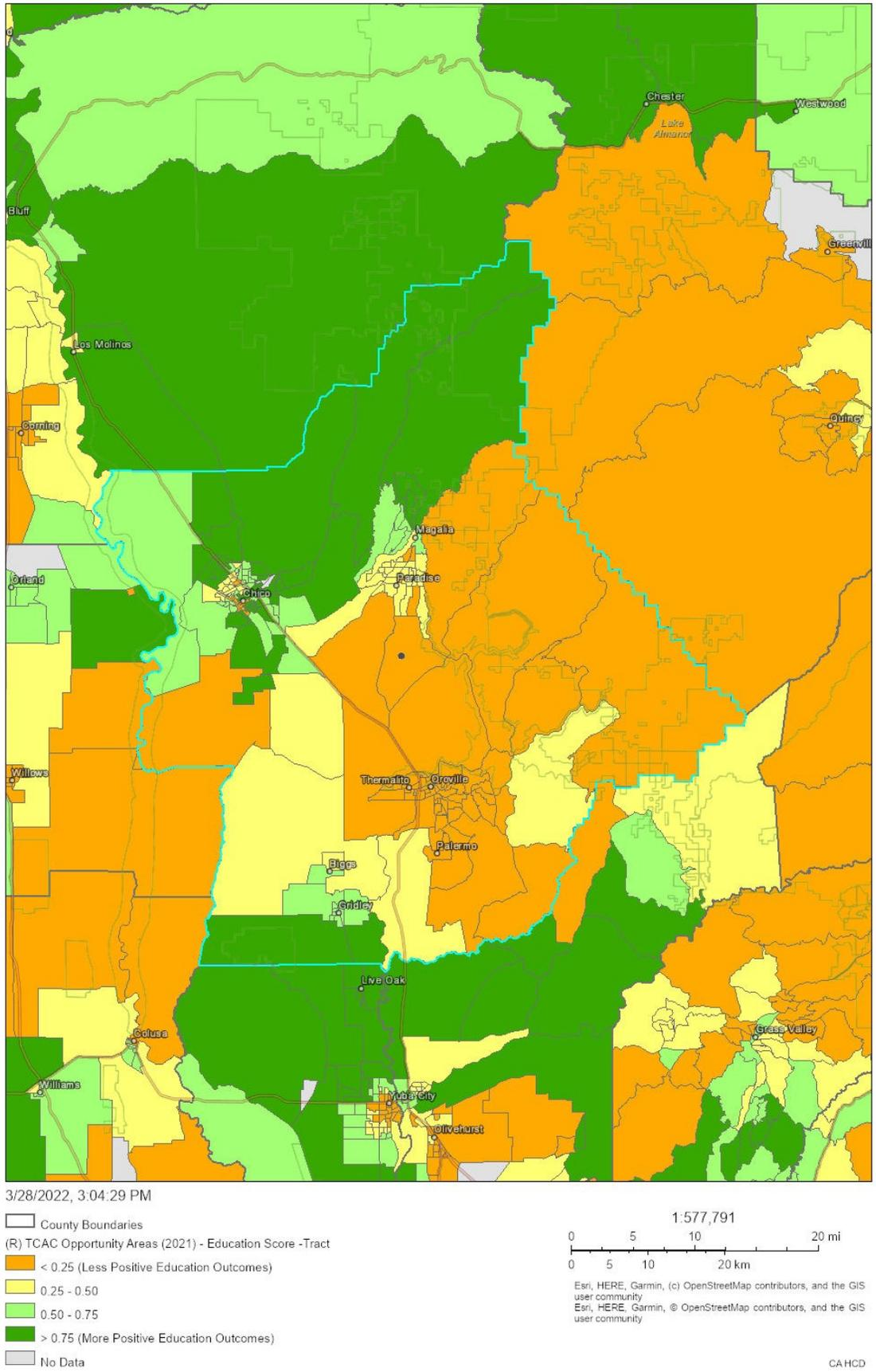

Figure 13.7: Butte County, Educational Opportunity, 2021



## Proximity to Jobs

The map “*City of Oroville, Job Proximity Index, 2017*” depicts block group data on residents’ proximity to jobs in the City of Oroville. The Jobs Proximity Index scores the accessibility of a given neighborhood to all job locations within an area. The index weighs the distance to employment centers, the amount of employment opportunities, and the competition for jobs.

Proximity to jobs in the City varies from furthest proximity to closest proximity. On average, residents in Census Tract 30.02 are in the closest proximity to jobs followed by residents in Census Tract 28 who are in relatively close proximity to jobs. Residents in Census Tract 33 have low proximity to jobs while residents in Census Tract 29 are in the furthest proximity from jobs. Residents in Census Tract 27 have moderate access to jobs.

In comparison, the map “*Butte County, Job Proximity Index, 2017*” illustrates that nearly half of Butte County is in furthest proximity to jobs with index scores less than 20. These scores are concentrated in the eastern parts of the County. In contrast, many areas in the western parts of the County are in close or closest proximity to jobs. It is important to note that the block groups that cover unincorporated areas of Butte County are geographically larger than the block groups closer to the County’s cities. Therefore, a resident may reside in a block group with a high index score but still have a significant commute to work.

Figure 14: City of Oroville, Job Proximity Index, 2017

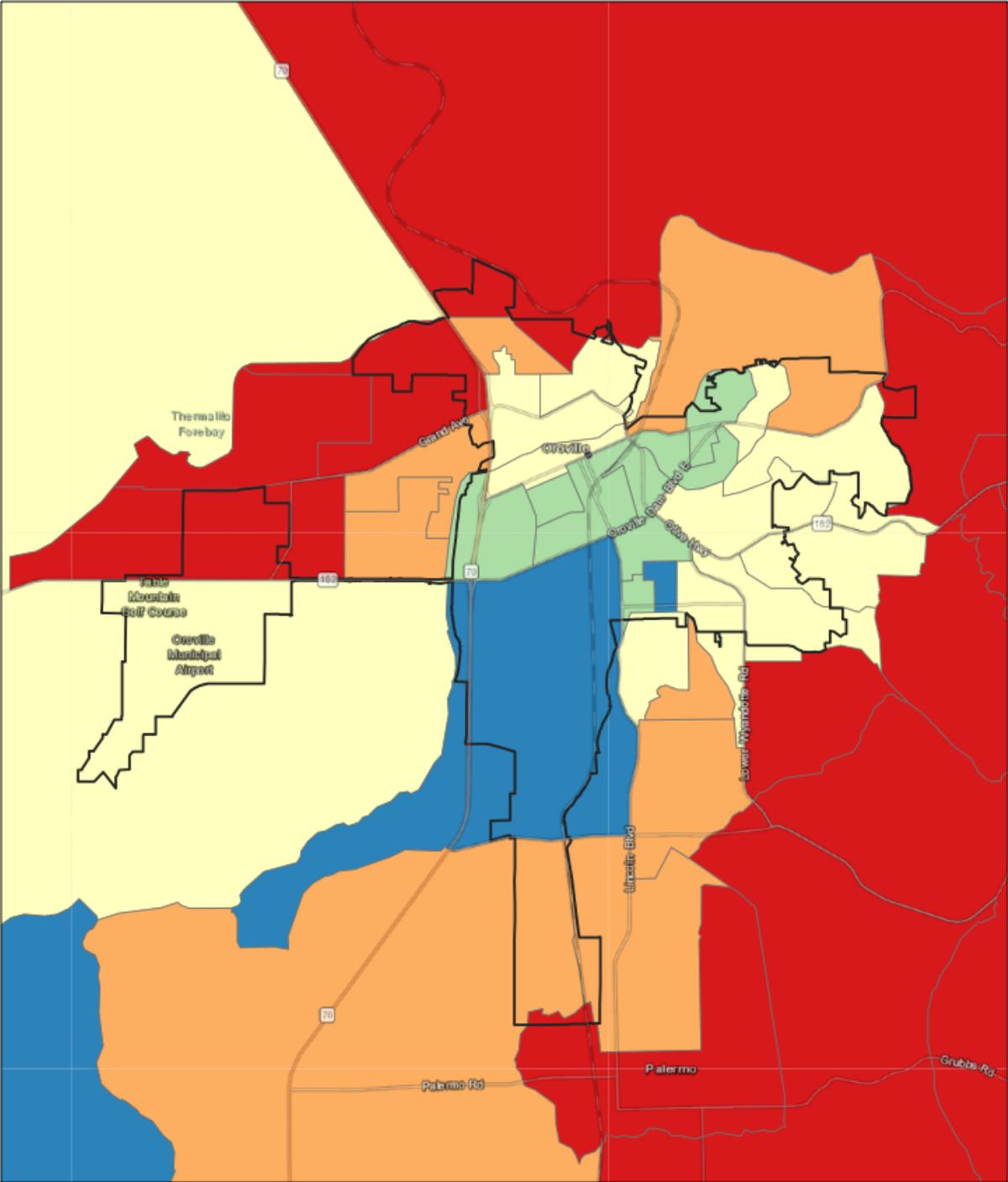

11/8/2021, 10:35:35 AM

City/Town Boundaries

(A) Jobs Proximity Index (HUD, 2014 - 2017) - Block Group

- < 20 (Furthest Proximity)
- 20 - 40
- 40 - 60
- 60 - 80
- > 80 (Closest Proximity)

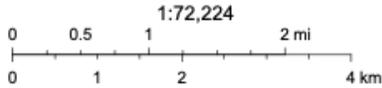
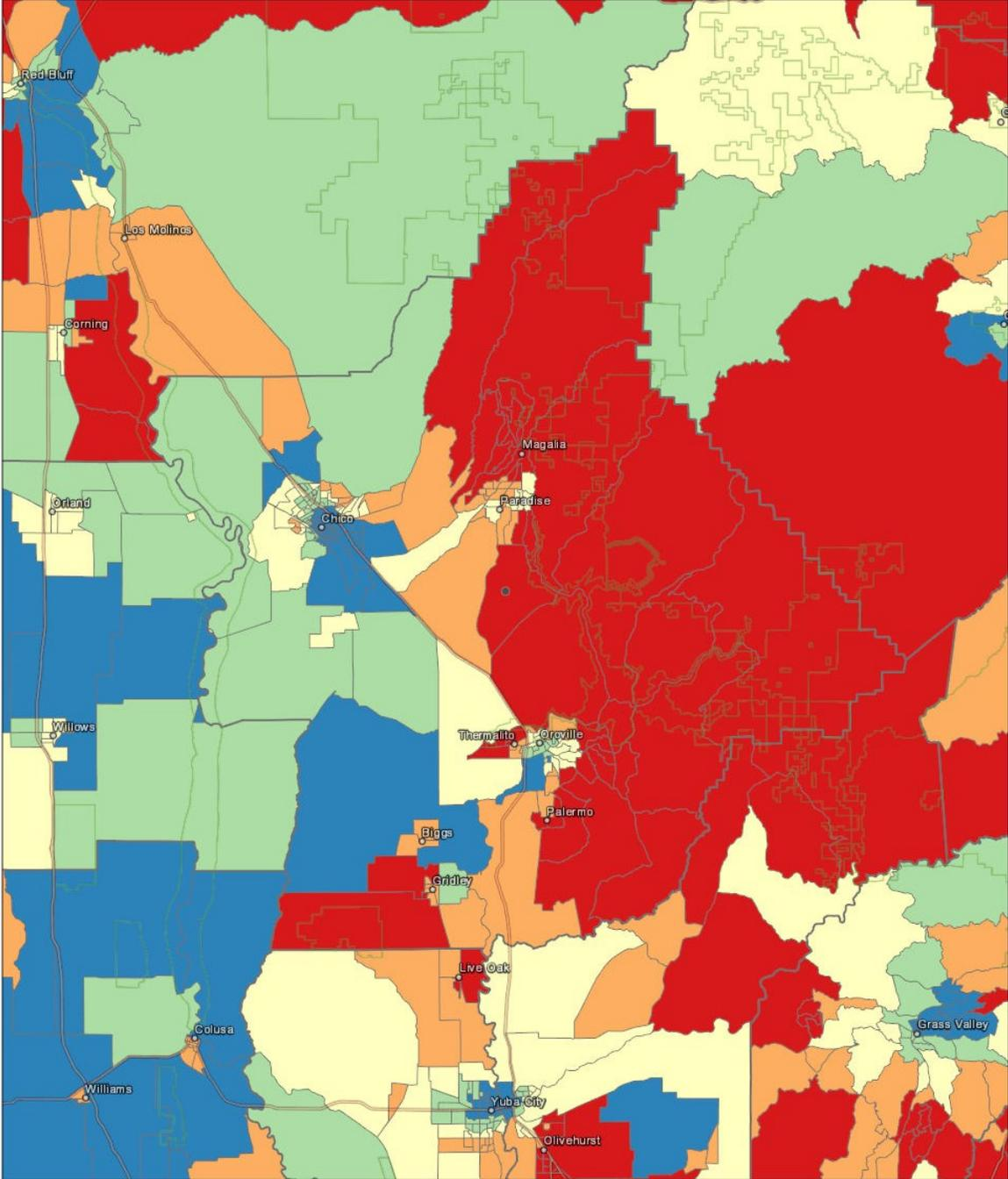

Figure 14.1: Butte County, Job Proximity Index Map, 2017



10/25/2021, 12:24:36 PM

County Boundaries

(A) Jobs Proximity Index (HUD, 2014 - 2017) - Block Group

- < 20 (Furthest Proximity)
- 20 - 40
- 40 - 60
- 60 - 80
- > 80 (Closest Proximity)

1:577,791

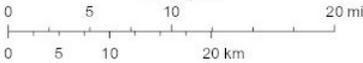

## Commuting Patterns

The table “*City of Oroville and Butte County, Commuting Data, 2019*” depicts data on commuting patterns for residents in the City of Oroville and Butte County in 2019. In both the City of Oroville and Butte County, a little over 70% of the working population drove alone to work.

Approximately 15% of workers carpooled in the City of Oroville, which is slightly higher than the number of residents that carpooled in Butte County. A significantly large portion of residents, or 46% of residents, work outside their place of residence, indicating that the City of Oroville is a commuter town. Interviews with local organizations indicate that many of these residents are employed in Chico.

The mean travel time to work is 19.1 minutes in the City of Oroville and 20.9 in Butte County. Half of the residents in the City of Oroville have a commute time of 14 minutes or less, which is slightly more than Butte County. Commute times in Oroville are similar to Butte County.

Figure 15: City of Oroville and Butte County, Commuting Data Table, 2019

	City of Oroville	Butte County
<b>WORKERS 16 YEARS AND OVER</b>	6,050	93,125
<b>MEANS OF TRANSPORTATION TO WORK</b>		
Drove alone in a car, truck, or van	72.9%	75.9%
Carpooled	14.8%	10.8%
<b>PLACE OF WORK</b>		
Worked in county of residence	91.9%	90.6%
Worked outside county of residence	8.1%	9.2%
Worked in place of residence	53.8%	47.8%
Worked outside place of residence	46.2%	39.1%
Not living in a city, town, or census-designated place	0%	13.1%
<b>TRAVEL TIME TO WORK</b>		
Mean travel time to work (minutes)	19.1	20.9
Less than 10 minutes	30%	23.1%
10 to 14 minutes	23.2%	22.7%
15 to 19 minutes	10%	16.3%
20 to 24 minutes	7.7%	8.2%
25 to 29 minutes	3.4%	5.2%
30 to 34 minutes	15.8%	11.3%
35 to 44 minutes	1.6%	3.3%
45 to 59 minutes	2.6%	4.3%
60 or more minutes	5.8%	5.7%

Source: U.S. Census Bureau, 2015-2019 American Community Survey

### Occupations and Earnings

The table “City of Oroville and Butte County, Occupations by Number of Persons and Median Earnings, 2015 and 2019” compares 2015 data to 2019 data on occupation and median earnings for the City of Oroville and Butte County. In this case, 2015 data was used instead of 2010 data because it was the oldest dataset available. According to the U.S. Bureau of Labor Statistics, the rate of inflation increased by 7.7% from 2015 to 2019. As of 2019, median earnings were

\$25,509. “Management, business, science, and arts occupations” earned the highest median earnings at \$49,557 whereas “service occupations” earned the lowest at \$16,219.

The City experienced overall decreases in median earnings for all employment sectors, with the exception of “Management, business, science, and arts occupations,” which increased by \$9,889. In comparison, Butte County had higher median earnings overall and saw increases in the median earnings of all employment sectors. These factors indicate that the economic prosperity of all residents may have significantly decreased in recent years.

Overall median earnings decreased by \$955 in the City and increased by \$4,489 in Butte County in 2019 compared to 2015. Butte County experienced 8% growth in the employed population or an increase of 6,684 employed individuals within that period.

Figure 16: City of Oroville and Butte County, Occupations and Earnings, 2019

Occupation	City of Oroville					Butte County				
	2015		2019		2015-2019	2015		2019		2015-2019
	Number of Persons	Median Earnings	Number of Persons	Median Earnings	Total Change	Number of Persons	Median Earnings	Number of Persons	Median Earnings	Total Change
Civilian employed population 16 years and over	N/A	\$26,464	N/A	\$25,509	-\$955	89,411	\$26,752	96,095	\$31,241	+\$4,489
Management, business, science, and arts occupations	N/A	\$39,688	N/A	\$49,577	+\$9,889	30,898	\$46,339	\$35,393	\$53,166	+\$6,827
Service occupations	N/A	\$18,562	N/A	\$16,219	-\$2,343	20,843	14,449	20,530	\$16,715	+\$2,266
Sales and office occupations	N/A	\$21,719	N/A	\$26,386	-\$4,667	21,162	\$24,044	20,278	\$26,750	+\$2,706
Natural resources, construction, and maintenance occupations	N/A	\$34,408	N/A	\$31,538	-\$2,870	8,158	\$30,649	8,591	\$36,409	+\$5,760
Production, transportation, and material moving occupations	N/A	\$28,221	N/A	\$21,310	-\$6,911	8,350	\$27,045	11,303	\$27,580	+\$535

## *Local Data and Knowledge*

Local data and knowledge is collected through interviews with regional stakeholders whose service areas include the City of Oroville.

### **North Valley Housing Trust**

On October 25, 2021, the authors conducted a phone interview with a staff member from the North Valley Housing Trust, which is an independent funding tool for locally driven affordable housing solutions in Northern California. The North Valley Housing Trust's office is located in Chico. The staff member also assists in organizing the Safe Space Winter Shelter in Chico and is a local realtor.

Staff commented that Butte County first-time homebuyers who can afford are home are often unable to find one because they are competing with all-cash offers in a competitive housing market. Those that have settled in satellite communities around Chico, including Oroville, where housing is more affordable, often become cost-burdened with increased transportation costs.

Extremely low-income households are unable to afford deposits, provide rental histories, or pay utility bills, which inhibits their ability to secure rental housing. They also have difficulty finding housing that meets their needs, which includes studios or one-bedrooms. Renters of all income backgrounds are facing price gouging, which involves large increases in rent exceeding 10% of the current cost. Executive Order No. N-85-20 issued by Governor Newsom protects counties impacted by wildfires from price gouging, but some residents do not have the resources to take legal action. Staff noted a rental registry could be beneficial in tracking rents and preventing price discrimination in the region.

Developers are having difficulty finding the finances or funds to get projects off the ground. The local governments in the region do not have the staff to apply for State or Federal funding sources which are complicated and can require costly consulting services. Policies such as the competitive public bid process, costly local utility requirements, or environmental reviews are especially prohibitive for small developers.

## *Other Relevant Factors*

### **Education**

HCD guidance for the Assessment of Fair Housing: Access to Opportunity section calls for data on educational disparities using school performance data from the California Department of Education's the California School Dashboard database.

**Figure 16.1: City of Oroville, Performance Level by State Indicator, 2019** shows grades served and performance level on six state indicators for each school located within the City of Oroville. The most

recent available data is from 2019. The six state indicators are as follows: chronic absenteeism, suspension rate, graduation rate, college/career, and academic (which includes performance in English language arts/literacy and mathematics). Performance for these measures is based on current year results and whether results improved from the prior year. Performance on state measures, using comparable statewide data, is represented by one of five colors. The performance level (color) is not included when there are fewer than 30 students in any year (i.e. N/A). The order of colors from highest performance to lowest performance is as follows:

- Blue (highest performance)
- Green
- Yellow
- Orange
- Red (lowest performance)

*(California Department of Education, California School Dashboard, 2019).*

When considering the locations of schools and performance levels of the schools from Figure 15, the authors can then compare to **Figure 13: City of Oroville, Access to Opportunity, 2021** to conduct an analysis on educational disparities as it relates to access to opportunity. Figure 13 depicts census tract level data on access to opportunity in the city of Oroville based on composite scores of economic, education, and environmental scores. As mentioned earlier in the analysis, 13 of 14 census tracts in the City are areas of TCAC areas of high segregation and poverty or low resources.

There are 39 schools located in Oroville according to the California Schools Dashboard. It is important to note that school performance data is limited. As depicted in Figure 15, numerous data indicators are not available for schools, such as English Learn Progress and College/ Career readiness. Therefore, the conclusions of this analysis are limited and may not accurately depict school performance due to the very limited data available.

The majority of Oroville schools score relatively poorly in relation to other schools in the state in measures of chronic absenteeism and suspension rates, ranging from red to orange, with the exception of STREAM charter. Many schools also score relatively low scores in suspension rates, ranging from red to orange with the exception of Bird Street Elementary, Hearthstone School, and Poplar Avenue Elementary. High suspension rates and chronic absenteeism is correlated with poor academic performance. Many schools range from red to orange on English and Language Arts and Mathematics performance indicators. In conclusion, most Oroville schools score relatively low in performance in comparison to other schools in the state.

STREAM charter has the best overall performance scores in the City of Oroville, scoring green in chronic absenteeism, orange in suspension rate, blue in English and Language arts and green in mathematics. STREAM charter is located just South of East Oroville Dam Blvd, which does not have a TCAC opportunity score due to missing/insufficient data. Therefore, the authors of this report cannot make conclusions based on missing information.

Because the City of Oroville primarily consists of “high segregation and poverty” and “low resource” areas, the geographic location of schools has marginal to no impacts on their access to opportunity. Furthermore, most schools have relatively low performance scores. Thus, this analysis concludes that there are no significant educational disparities that correlate to access to opportunity as defined by TCAC.

Figure 16.1: City of Oroville, Performance Level by State Indicator, 2019

School Name	Grades Served	Chronic Absenteeism	Suspension Rate	English Learner Progress	Graduation Rate	College/ Career	English Language Arts	Mathematics
Nelson Avenue Middle	6-8	Yellow	Orange	N/A	N/A	N/A	Orange	Orange
Feather Falls Union Elementary	K-12	N/A	N/A	N/A	N/A	N/A	N/A	N/A
Prospect High Continuation	9-12	N/A	Yellow	N/A	Yellow	Red	N/A	N/A
Helen M. Wilcox Elementary	K-3	Yellow	Yellow	N/A	N/A	N/A	Yellow	Yellow
Pioneer Community Day	1-6	N/A	N/A	N/A	N/A	N/A	N/A	N/A
Ophir Elementary	K-5	Orange	Orange	N/A	N/A	N/A	Green	Yellow
Stanford Avenue Elementary	K-5	Red	Yellow	N/A	N/A	N/A	Yellow	Yellow
Las Plumas High	9-12	N/A	Orange	N/A	Yellow	Yellow	Green	Yellow
Golden Hills Elementary	4-5	Orange	Red	N/A	N/A	N/A	Orange	Orange
Honcut	K-3	N/A	N/A	N/A	N/A	N/A	N/A	N/A
Feather Falls Elementary	K-8	N/A	N/A	N/A	N/A	N/A	N/A	N/A
Wyandotte Academy	K-5	Orange	Yellow	N/A	N/A	N/A	Yellow	Yellow
Oroville Union High	9-Adult	N/A	Orange	N/A	Yellow	Yellow	Green	Yellow
Come Back Butte Charter	9-12	N/A	Blue	N/A	Red	Orange	N/A	N/A
Table Mountain	K-12	N/A	Blue	N/A	N/A	N/A	N/A	N/A
Concow Elementary	K-8	Red	Red	N/A	N/A	N/A	N/A	N/A

Ishi Hills Middle	6-8	Orange	Orange	N/A	N/A	N/A	Yellow	Yellow
Bird Street Elementary	K-3	Red	Green	N/A	N/A	N/A	N/A	N/A
Ipakanni Early College Charter		N/A	N/A	N/A	N/A	N/A	N/A	N/A
Golden Feather Union Elementary	K-8	Red	Red	N/A	N/A	N/A	N/A	N/A
Hearthstone School	K-12	Yellow	Blue	N/A	Green	Yellow	Yellow	Orange
Heritage Community Day	4-8	N/A	N/A	N/A	N/A	N/A	N/A	N/A
Berry Creek Elementary	K-8	Orange	Orange	N/A	N/A	N/A	N/A	N/A
Butte County Special Education	K-12	Orange	Red	N/A	N/A	N/A	N/A	N/A
Oroville City Elementary	P-8	Orange	Yellow	N/A	N/A	N/A	Yellow	Yellow
BASES Learning Center		N/A	N/A	N/A	N/A	N/A	N/A	N/A
STREAM Charter	K-8	Green	Orange	N/A	N/A	N/A	Blue	Green
Oakdale Heights Elementary	K-5	Red	Yellow	N/A	N/A	N/A	Red	Orange
Sierra Avenue Elementary	K-5	Red	Yellow	N/A	N/A	N/A	Red	Orange
Sierra Del Oro Inclusive Preschool	P	N/A	N/A	N/A	N/A	N/A	N/A	N/A
Butte County Office of Education	K-12	Orange	Orange	N/A	N/A	N/A	N/A	N/A
Thermalito Union Elementary	K-8	Yellow	Orange	N/A	N/A	N/A	Orange	Orange
Poplar Avenue Elementary	K-5	Orange	Green	N/A	N/A	N/A	Orange	Orange

Pioneer Union Elementary	K-8	Orange	Orange	N/A	N/A	N/A	N/A	N/A
Oroville Adult Education Center	A	N/A	N/A	N/A	N/A	N/A	N/A	N/A
Central Middle	5-8	Yellow	Orange	N/A	N/A	N/A	Orange	Red
Oroville High Community Day	9-12	N/A	Orange	N/A	N/A	N/A	N/A	N/A
Oroville High	9-12	N/A	Orange	Green	Green	Yellow	Yellow	Yellow
Plumas Avenue Elementary	K-5	Orange	Yellow	N/A	N/A	N/A	Green	Yellow

Source: California Department of Education, California School Dashboard, 2019

## Public Transportation

The City of Oroville's public transportation system includes bus services but does not include air or train services. Residents can access Butte Regional Transit (B-Line) services, which is operated by the Butte County Association of Governments and provides both fixed-route and shared paratransit services.

The B-line bus service provides intercity transportation within Oroville and regional transportation to Biggs, Chico, Gridley, and Paradise. In an interview with the Butte County Association of Governments, staff reported that all fixed route and paratransit buses are ADA compatible. However, some of Oroville's bus stops do not provide ADA-compliant facilities, bus-route maps, or shelters to protect riders (*Balanced Mode Circulation Plan, City of Oroville, 2015*). B-line services operate seven days a week apart from six public holidays, but some routes do not operate every day. In 2019, B-Line bus services offered an average of 5,822 rides to residents in the City of Oroville (*Butte County Association of Governments, 2019*).

*Residents can access more information such as schedules, maps, and fare prices here:*

<http://www.blinetransit.com/documents/B-LineWeb2019.pdf>

The B-Line Paratransit service offers on-demand, door-to-door shared ride services for seniors 70 years and older or persons with physical disabilities who are not able access the fixed-route service. This service is available at a low-cost to residents per request. In 2019, B-Line Paratransit offered an average of 1,214 rides to residents in the City of Oroville (*Butte County Association of Governments, 2019*).

*Residents can estimate the cost of a fare using the paratransit Fare Estimator here:*

[https://gicwebsrv.csuchico.edu/webmaps/bcag\\_paratransit/prod/](https://gicwebsrv.csuchico.edu/webmaps/bcag_paratransit/prod/)

The map below depicts the service areas for the B-Line Fixed Route and Paratransit services in Butte County.

Figure 16.2: B-Line Fixed Route and Paratransit Service Area Map

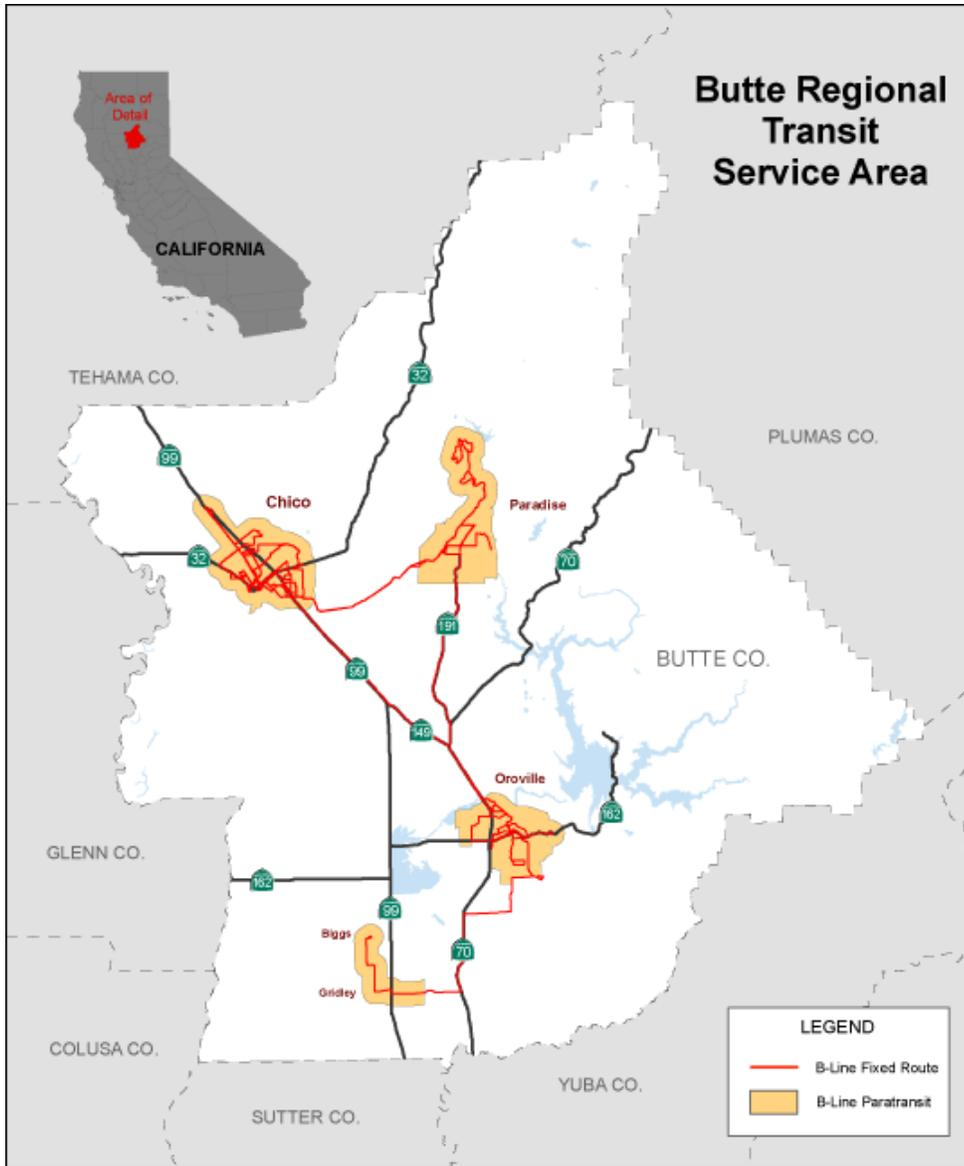

In accordance with the California State Transportation Development Act, the Butte County Association of Governments must identify any unmet public transit needs. In general, ridership rates have been decreasing over the past few years. After the 2018 Camp Fire, several routes were modified as a result of the displacement of people. The report concluded that there are no unmet transit needs that are reasonable to meet. The analysis concluded that Oroville East, Oroville South, and Oroville include transit dependent and transit disadvantaged places or areas with high concentrations of poverty or riders that are most likely to use transit. In general, persons 65 and over and youth 5-19 are most likely to use transit services and qualify for reduced fares in Butte County. (*Unmet Transit Needs Assessment-2021-2022, Butte County Association of Governments, 2022*). Butte County Association of Governments is currently in the process of updating its bus lines to increase transit ridership and improve transit accessibility.

The City of Oroville last updated its “Balanced Mode Circulation Plan” in 2015, which details transit options and plans for future development for bicycle and pedestrian infrastructure. The plan improves the safety, accessibility, connectivity, education, maintenance, and implementation of bicycle and pedestrian infrastructure and facilities.

### **Housing Accessibility**

Due to the high proportion of low-income, senior residents and residents with a disability, this section considers the number of affordable housing options with ADA accommodations in the City. Currently, the Housing Authority of the County of Butte manages 130 affordable housing units in Oroville and 63 units are accessible for people with disabilities. There are also 69 privately-owned and managed, affordable housing units in Oroville, and 40 units are for the elderly. In total, there are approximately 103 public housing units in Oroville that are ADA accessible.

### ***Summary of Findings***

Nearly all of the Census Tracts in the City of Oroville are considered low resource areas or areas of high segregation and poverty with very low economic and educational outcome scores. Block Group 6, Census Tract 27 is a moderate resource area with the highest economic outcome score in the entire City. Census Tracts 25, 27, 29, and 31 experience the most positive environmental outcomes in the City whereas residents in Census Tracts 30.01, 20.02, 33, and 37 experience the least positive environmental outcomes. The City of Oroville experiences less positive economic and education outcomes than other portions of Butte County, but more positive environmental outcomes. On average, schools in Oroville perform relatively poorly to other schools in the State of California.

Residents in Census Tract 33 have low proximity to jobs while residents in Census Tract 29 are in the furthest proximity from jobs. Most residents have a commute time that is 14 minutes or less. A significantly large portion of residents, or 46% of residents work outside their place of residence. Data from BCAG indicates that residents appear to have equitable access to transportation. The City experienced overall decreases in median earnings for all employment sectors except the “Management, business, science, and arts occupations” sector, which may indicate decreases in the economic prosperity of residents. The average median earnings decreased by \$955, whereas that number increased in Butte County.

Staff from North Valley Housing Trust indicated that residents in Butte County are having trouble purchasing homes because due to an increase in competitive bidders that may offer all-cash offers, much like other regions of the state. Renters from all income backgrounds are facing rent gouging and are having trouble finding units that fit their needs, including small units and accessible units.

## E. DISPROPORTIONATE HOUSING NEEDS AND DISPLACEMENT RISK

The fifth and final section of the Assessment of Fair Housing is disproportionate housing needs and displacement risk. This part of the analysis considers how people with protected characteristics (such as race, ethnicity, income class, sexual orientation, people with disabilities, etc.) and households with low incomes experience disproportionate housing needs when compared to other populations.

### *Local and Regional Patterns and Trends*

This section includes data tables, narratives, and maps to illustrate local and regional patterns and trends regarding disproportionate housing needs and displacement risk. For the purposes of this analysis, disproportionate housing needs and displacement risk includes the income needed to afford housing, housing tenure, housing problems, displacement due to natural disaster, and mobile home parks.

#### **Income Needed to Afford Rental Housing**

The table “*Butte County, Annual Income Needed to Afford Rental Housing, 2021*” depicts the annual income needed to afford zero to four-bedroom rental units located in Butte County. The annual income needed to afford a one-bedroom unit is \$36,160 and a two-bedroom unit is \$47,680. A 2019 survey indicated that more than half of the population in the City of Oroville has a household income less than \$34,999, which means more than half of the population cannot afford a one-bedroom unit. In 2019, the median household income for a household of two persons was \$48,558 and for a household of three persons was \$33,309 (refer to: Figure 17: Butte County, Annual Income Needed to Afford Rental Housing Table, 2021). These findings indicate that most three-person households in Oroville can only afford the average-priced studio in Butte County.

**Figure 17: Butte County, Annual Income Needed to Afford Rental Housing Table, 2021**

Unit Size	Annual Income Needed to Afford Unit
Zero-bedroom (studio)	\$33,000
One-bedroom	\$36,160
Two-bedroom	\$47,680
Three-bedroom	\$67,680
Four-bedroom	\$82,560

Source: National Low Income Housing Coalition, 2021 Out of Reach

## Housing Tenure

The table *“City of Oroville, Race and Ethnicity, 2010 and 2019”* depicts housing tenure (own versus rent) for the City of Oroville in 2010 and 2019. The table *“Butte County, Race and Ethnicity, 2010 and 2019”* depicts housing tenure (own versus rent) for Butte County in 2019 compared to 2010.

In 2019 in the City of Oroville, White households made up 83% of owner-occupied housing units, but only 64% of the population. As mentioned in the previous data tables, 64% of the population of the City of Oroville identifies as White, 14% identifies as Hispanic or Latino, and 9% identifies as Asian. However, 11% of Hispanic or Latino households are owner-occupied and only 4.6% of Asian households are owner-occupied. These findings suggest that Asian residents are significantly less likely to own a home than White and Hispanic or Latino residents.

The number of owner-occupied units increased by 7.4% and the number of renter-occupied increased by 0.2% for Hispanic or Latino residents in the City of Oroville in 2019 compared to 2010. For units that belong to White households, the number of owner-occupied decreased by 8.8% while the number of renter-occupied units increased by 1.8%. This could be due to the significant increase in the number of households that identify as Hispanic or Latino, Asian, or two or more races during that same time period.

In comparison, Butte County experienced a significant decrease in the number of White households while the number of households that identify as Hispanic or Latino increased significantly. However, ownership trends remained relatively steady with a slight uptick in the number of Hispanic residents that reside in owner-occupied units by 1.7%.

Figure 18: City of Oroville, Housing Tenure by Race and Ethnicity Table, 2010 and 2019

Race/Ethnicity	City of Oroville									
	2010				2019				2010-2019	
	Owner-occupied Housing Units		Renter-occupied Housing Units		Owner-occupied Housing Units		Renter-occupied Housing Units		Owner-occupied	Renter-occupied
	Number	Percent	Number	Percent	Number	Percent	Number	Percent	Change	
<i>One Race</i>										
White	2,393	91.6%	2403	77.8%	2,438	82.8%	2,771	79.6%	-8.8%	+1.8%
Black or African American	39	1.5%	108	3.5%	28	1%	193	5.5%	-0.5%	+2%
American Indian and Alaska Native	0	0%	62	2%	64	2.2%	61	1.8%	+2.2%	-0.2%
Asian	42	1.6%	173	5.6%	134	4.6%	218	6.3%	+3%	+0.7%
Native Hawaiian or Pacific Islander	3	0.1%	15	0.5%	0	0%	0	0%	-0.1%	-0.5%
Some Other Race	42	1.6%	136	4.4%	64	2.2%	11	0.3%	+0.6%	-4.1%
<i>Two or More Races</i>	94	3.6%	198	6.4%	215	7.3%	229	6.6%	+3.7%	+0.2%
<i>Ethnicity</i>										
Hispanic or Latino Origin	91	3.5%	210	6.8%	320	10.9%	244	7%	+7.4%	+0.2%
White, not Hispanic/Latino	2,348	89.9%	2,363	76.5%	2,195	74.6%	2,556	73.4%	-15.3%	-3.1%

Source: U.S. Census 2006-2010 and 2015-2019 American Community Survey

Figure 18.1: County of Butte, Housing Tenure by Race and Ethnicity Table, 2010 and 2019

Race/Ethnicity	Butte County									
	2010				2019				2010 vs. 2019	
	Owner-occupied Housing Units		Renter-occupied Housing Units		Owner-occupied Housing Units		Renter-occupied Housing Units		Owner-occupied	Renter-occupied
	Number	Percent	Number	Percent	Number	Percent	Number	Percent	Change	
<i>One Race</i>										
White	47,874	91.5%	27,410	82.7%	45,588	90.6%	28,683	82.0%	-0.9%	-0.7%
Black or African American	419	0.8%	663	2.0%	185	0.4%	826	2.4%	-0.4%	+0.4%
American Indian and Alaska Native	471	0.9%	530	1.6%	507	1.0%	511	1.5%	+0.1%	-0.1%
Asian	942	1.8%	1,326	4.0%	1,104	2.2%	1,530	4.4%	+0.4%	+0.4%
Native Hawaiian or Pacific Islander	52	0.1%	66	0.2%	30	0.1%	46	0.1%	0%	-0.1%
Some Other Race	1,308	2.5%	1,591	4.8%	1,269	2.5%	1,719	4.9%	0%	+1%
<i>Two or More Races</i>	1,308	2.5%	1,591	4.8%	1,648	3.3%	1,674	4.8%	+0.8%	0%
<i>Ethnicity</i>										
Hispanic or Latino Origin	3,715	7.1%	4,309	13.0%	4,420	8.8%	5,468	15.6%	+1.7%	+2.6%
White, not Hispanic/Latino	45,624	87.2%	25,289	76.3%	42,883	85.2%	25,376	72.5%	-2%	-3.8%

Source: U.S. Census 2006-2010 and 2015-2019 American Community Survey

### ***Percent of Renter-Occupied Housing Units***

The map, “*City of Oroville, Renter-occupied Housing Units, 2021*” indicates the proportion of renter-occupied housing units present within each census tract. The map below indicates that 60-80% of residents live in rental units in Census Tract 28, which is the largest concentration of rental units within the entire City. In addition, 40-60% of residents live in rental units in Census Tracts 25, 29, 30.01, and 30.02. High concentrations of rental units may be associated with the low median household income and high occurrence of poverty that is also present in these areas.

The City of Oroville has significantly more renter-occupied housing units than Butte County. Roughly 40% or less of the population resides in renter-occupied housing units in most areas of Butte County. A larger proportion of renters reside in areas surrounding the Cities of Chico, Oroville, and small portion of the County near the City of Gridley. Chico’s large number of rental housing units is likely correlated to Butte College and Chico State University, which brings in many students that reside in Chico while attending college.

Figure 18.2: City of Oroville, Renter-occupied Housing Units, 2021

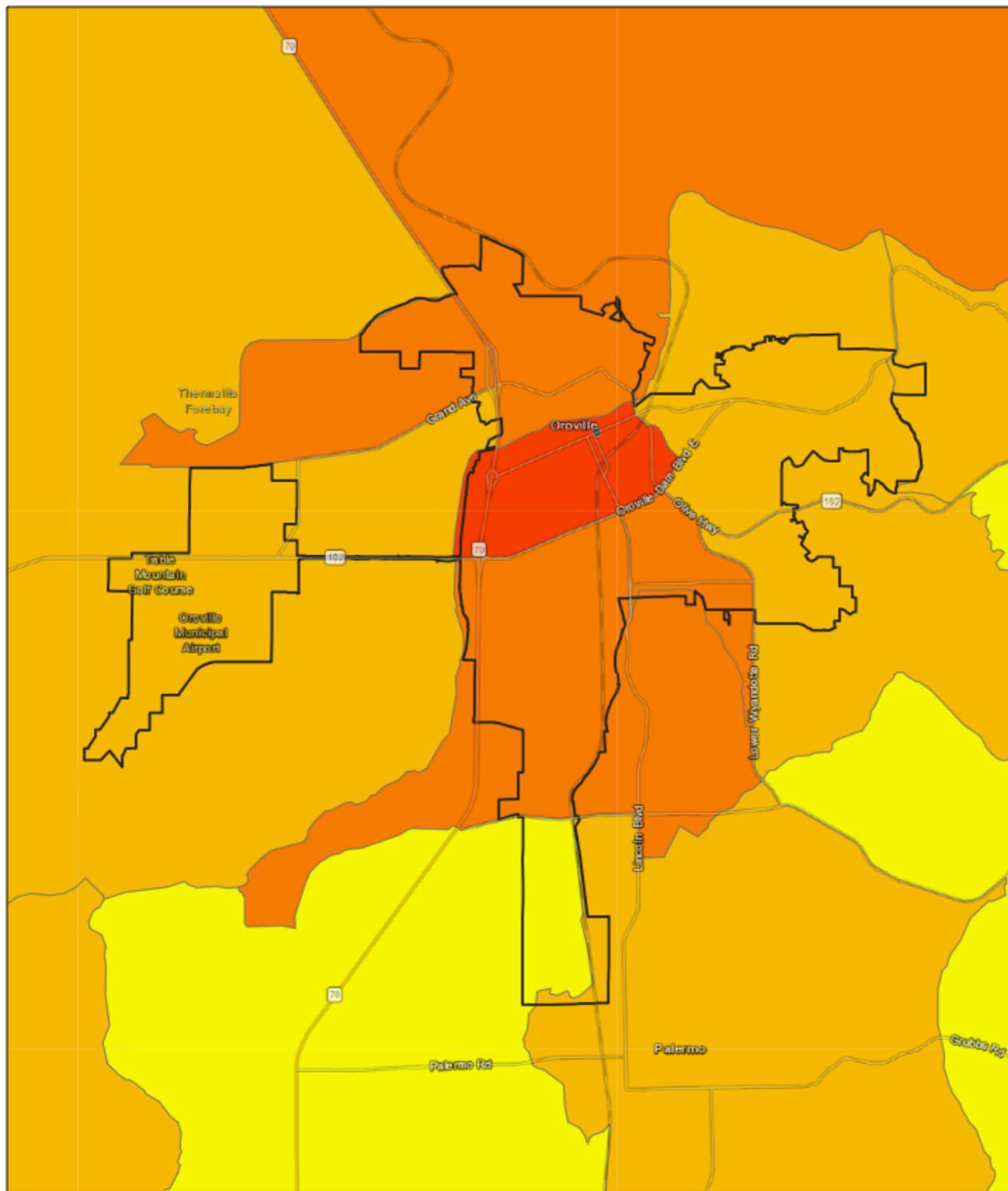

11/8/2021, 11:08:36 AM

City/Town Boundaries

(R) Percent of households in renter - occupied housing units (HUD) - Tract

- ≤ 20 %
- 20% - 40%
- 40% - 60%
- 60% - 80%

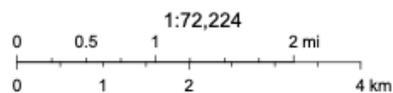
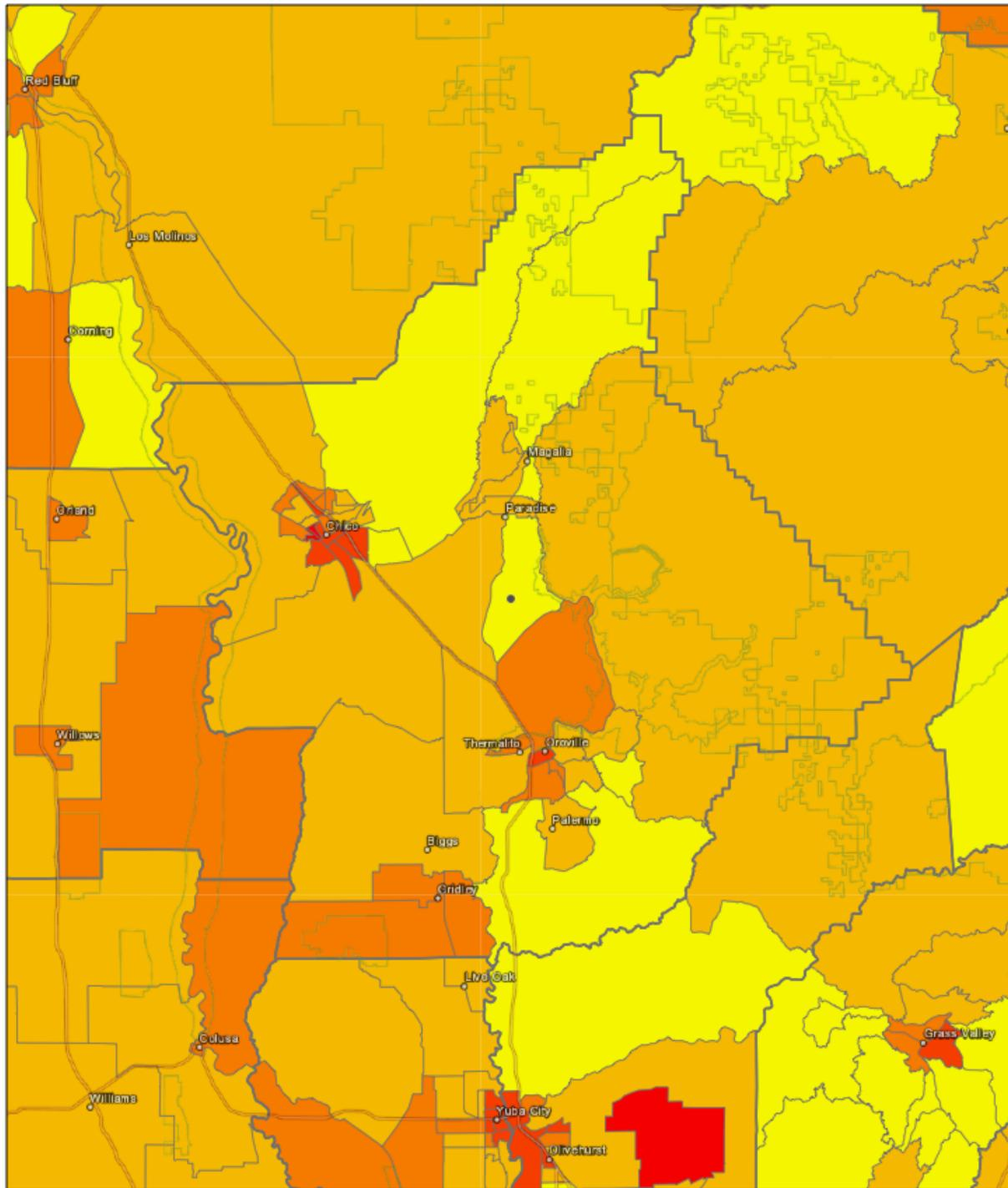

Figure 18.3: Butte County, Renter-occupied Housing Units, 2021



12/22/2021, 4:13:23 PM

County Boundaries

(R) Percent of households in renter - occupied housing units (HUD) - Tract

- ≤ 20 %
- 20% - 40%
- 40% - 60%
- 60% - 80%
- > 80%

1:577,791

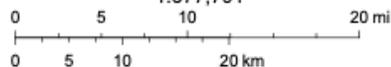

## Housing Problems

The table *“City of Oroville, Housing Problems, 2010 and 2018”* and the table *“Butte County, Housing Problems, 2010 and 2018”* compare the number of owners and renters in the City of Oroville and Butte County in 2010 compared to 2018. Data from 2018 is used as it is the most recent available data as of October 2021.

A Housing Problem, as defined by HUD, is a unit that: 1) Lacks complete kitchen facilities; 2) Lacks complete plumbing facilities; 3) Has more than 1 person per room; or 4) Has a housing cost burden over 30% of income. A Severe Housing Problem, as defined by HUD, is a unit that: 1) Lacks complete kitchen facilities; 2) Lacks complete plumbing facilities; 3) Has more than 1.5 persons per room; or 4) Has a housing cost burden over 50% of income. As of 2018, 70% of occupants that have at least one of four Housing Problems and one of four Severe Housing Problems are renters. From 2010 to 2018, the number of total households experiencing Housing Problems increased significantly for both renters and owners in the City.

In comparison to Butte County, the number of renters experiencing Housing Problems in Oroville is significantly larger. However, the number of renters experiencing Housing Problems increased significantly from 2010 to 2018 in Butte County. These findings indicate the renters are more likely to experience Housing Problems than homeowners, and that trend is worsening.

Figure 19: City of Oroville, Housing Problems Table, 2010 and 2018

Housing Problems	2010					2018					2010 vs. 2018	
	Owners	Owner % of Total	Renters	Renter % of Total	Total	Owners	Owner % of Total	Renters	Renter % of Total	Total	Owner % Change	Renter % Change
Household has at least 1 of 4 Housing Problems	850	34.6%	1,610	65.4%	2,460	910	30.7%	2,050	69.3%	2,960	-3.9%	+3.9%
Household has at least 1 of 4 Severe Housing Problems	390	30%	910	70%	1,300	515	28.7%	1,280	71.3%	1,795	-1.3%	+1.3%

Source: U.S. Department of Housing and Urban Development, 2006-2010 and 2014-2018 Comprehensive Housing Affordability Strategy (CHAS) Data

Figure 19.1: Butte County, Housing Problems Table, 2010 and 2018

Housing Problems	2010					2018					2010 vs. 2018	
	Owners	Owner % of Total	Renters	Renter % of Total	Total	Owners	Owner % of Total	Renters	Renter % of Total	Total	Owner % Change	Renter % Change
Household has at least 1 of 4 Housing Problems	18,765	49.5%	19,165	50.5%	37,930	14,520	41.1%	20,815	58.9%	35,335	-8.4%	+8.4%
Household has at least 1 of 4 Severe Housing Problems	8,135	42.2%	11,135	57.8%	19,270	6,735	34.4%	12,865	65.6%	19,600	-7.8%	+7.8%

Source: U.S. Department of Housing and Urban Development, 2006-2010 and 2014-2018 Comprehensive Housing Affordability Strategy (CHAS) Data

### ***Overcrowded Households***

The map, “*City of Oroville, Overcrowded Households, 2015*” depicts the number of households that have greater than one occupant per room. In areas that are light green, 8.2% of households are overcrowded. In areas that are green, 8.3-12% of households are overcrowded, which includes Census Tracts 30.02 and 37. In areas that are blue, 15-20% of households are overcrowded, which is double the State average and this includes Census Tracts 29 and 30.01.

The map, “*Butte County, Overcrowded Households, 2015*” shows the percentage of overcrowded households (more than 1.0 persons per room) by census tract in Butte County. The most recent available data is from 2015. Most census tracts in the county are at or below the statewide average of 8.2% overcrowded households. The census tracts around Oroville and Thermalito have higher than average overcrowded households – between 8.3% to 20% of all households in those census tracts. Chico has one census tract with higher-than-average overcrowded households. (*HCD AFFH Data Resources and Mapping Tool: 2015 Healthy Communities Data and Indicators Project*).

Figure 19.2: City of Oroville, Overcrowded Households, 2015

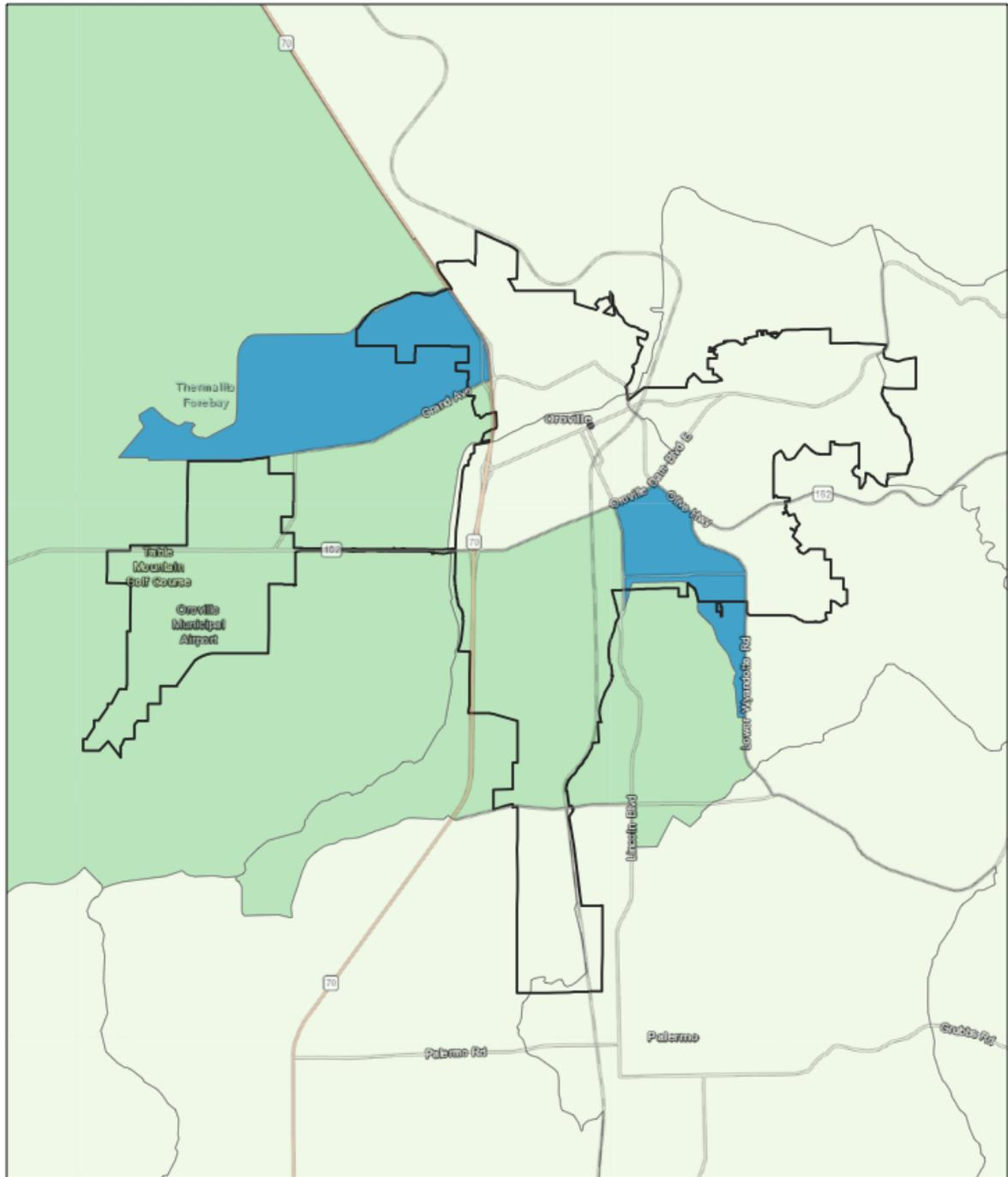

11/8/2021, 11:09:13 AM

City/Town Boundaries

(R) Overcrowded Households (CHHS) - Tract

≤ 8.2% (Statewide Average)

8.3% - 12%

15.01% - 20%

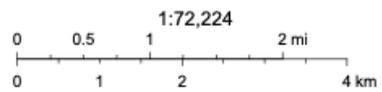
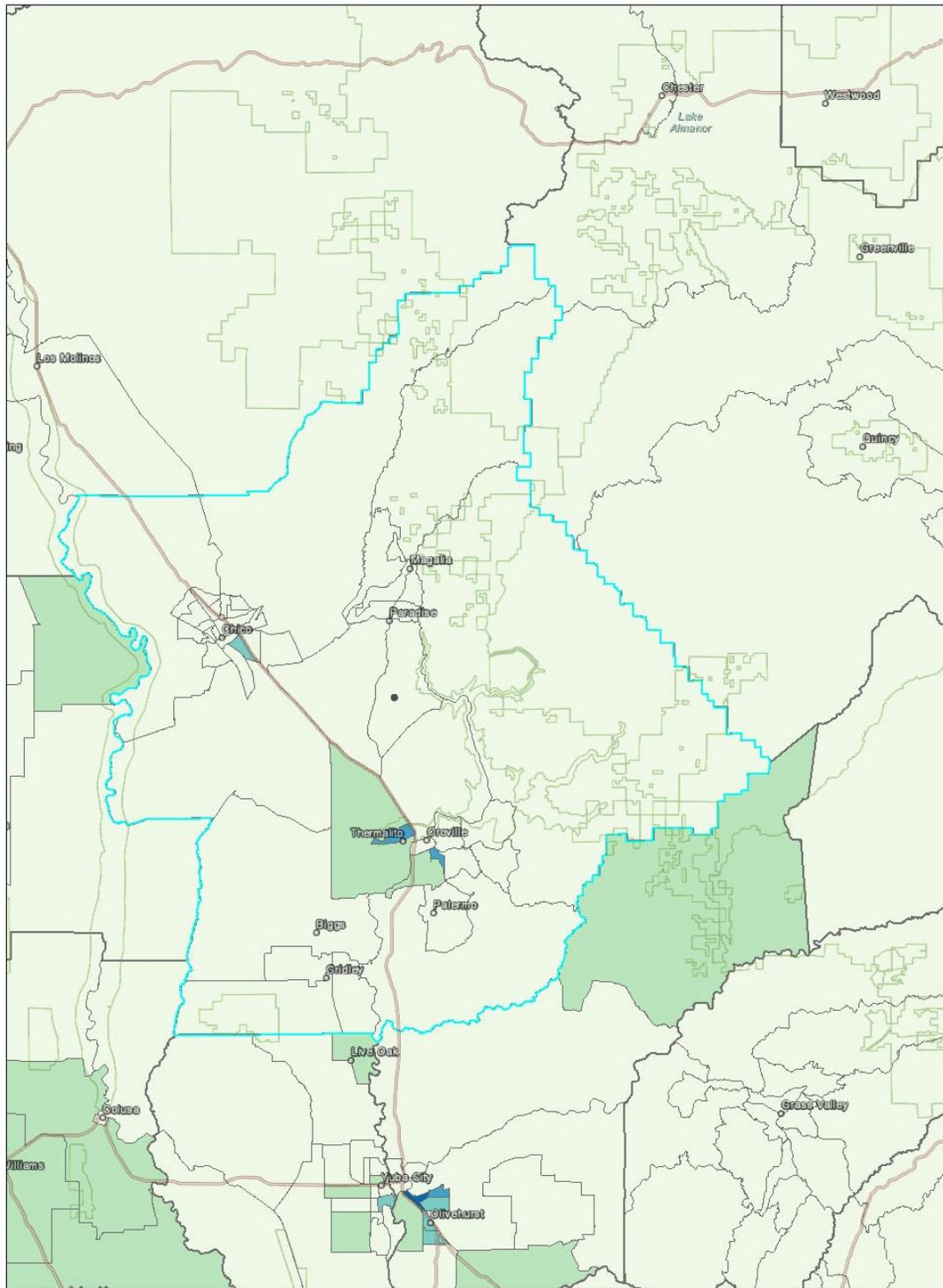
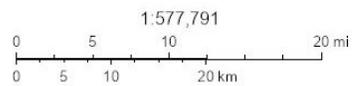

Figure 19.3: Butte County, Overcrowded Households Map, 2015



3/28/2022, 3:11:57 PM

- County Boundaries
- (R) Overcrowded Households (CHHS) - Tract
- ≤ 8.2% (Statewide Average)
- 8.3% - 12%
- 12.01% - 15%
- 15.01% - 20%
- > 20%



Esri, HERE, Garmin, (c) OpenStreetMap contributors, and the GIS user community  
Esri, HERE, Garmin, © OpenStreetMap contributors, and the GIS user community

### ***Overpayment by Homeowners***

The map, “*City of Oroville, Overpayment by Homeowners, 2019*” depicts the number of households that pay 30% or more of their income toward homeownership costs. An estimated 40-60% of owners residing in areas that are shaded in orange pay more than 30% of their income toward housing costs. This includes Census Tracts 25 and 37. An estimated 60-80% of homeowners residing in areas that are shaded red pay more than 30% of their income toward housing costs. This includes Census Tract 30.01. Finally, an estimated 20-40% of homeowners residing in areas that are shaded yellow pay more than 30% of their income toward housing costs, which includes the rest of the census tracts that encompass the City.

The map, “*Butte County, Overpayment by Owners Map, 2019*” depicts the percentage of owner households with mortgages whose monthly owner costs are 30% or more of household income. Household income is based on earnings in the past 12 months prior to the survey. The only census tracts with 60-80% of owner households with overpayment are located in Chico and Oroville. Most of the county has 20-40% or 40-60% of owner households with overpayment. The census tract in northeast Butte County between Chico and Magalia/Paradise has less than 20% of owner households with overpayment. (*HCD AFFH Data Resources and Mapping Tool: 2015-2019 American Community Survey*).

Figure 19.4: City of Oroville, Overpayment by Homeowners, 2019

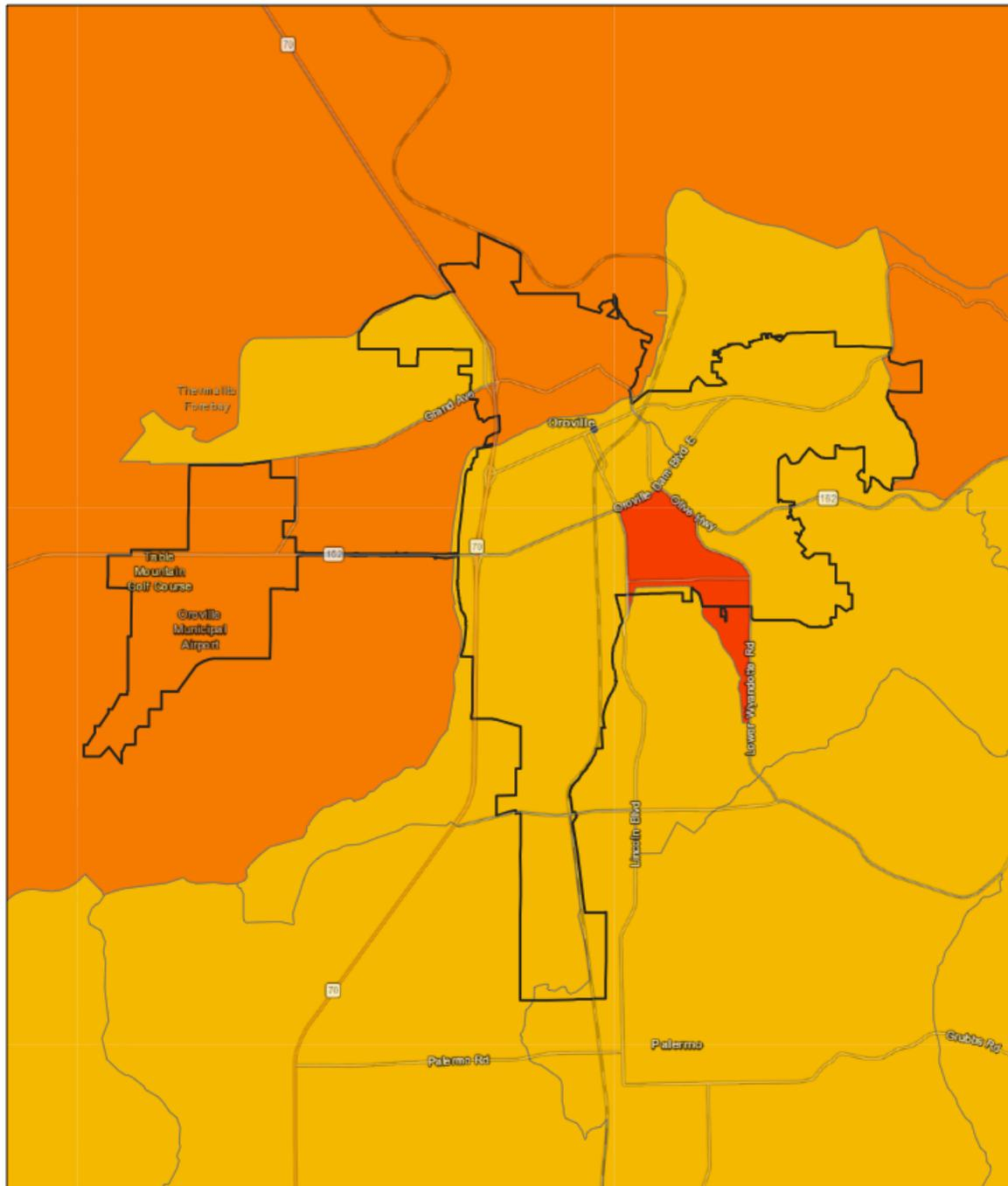

11/8/2021, 11:06:37 AM

City/Town Boundaries

(R) Overpayment by Home Owners (ACS, 2015 - 2019) - Tract

20% - 40%

40% - 60%

60% - 80%

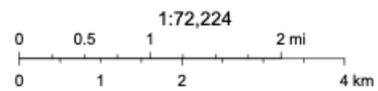
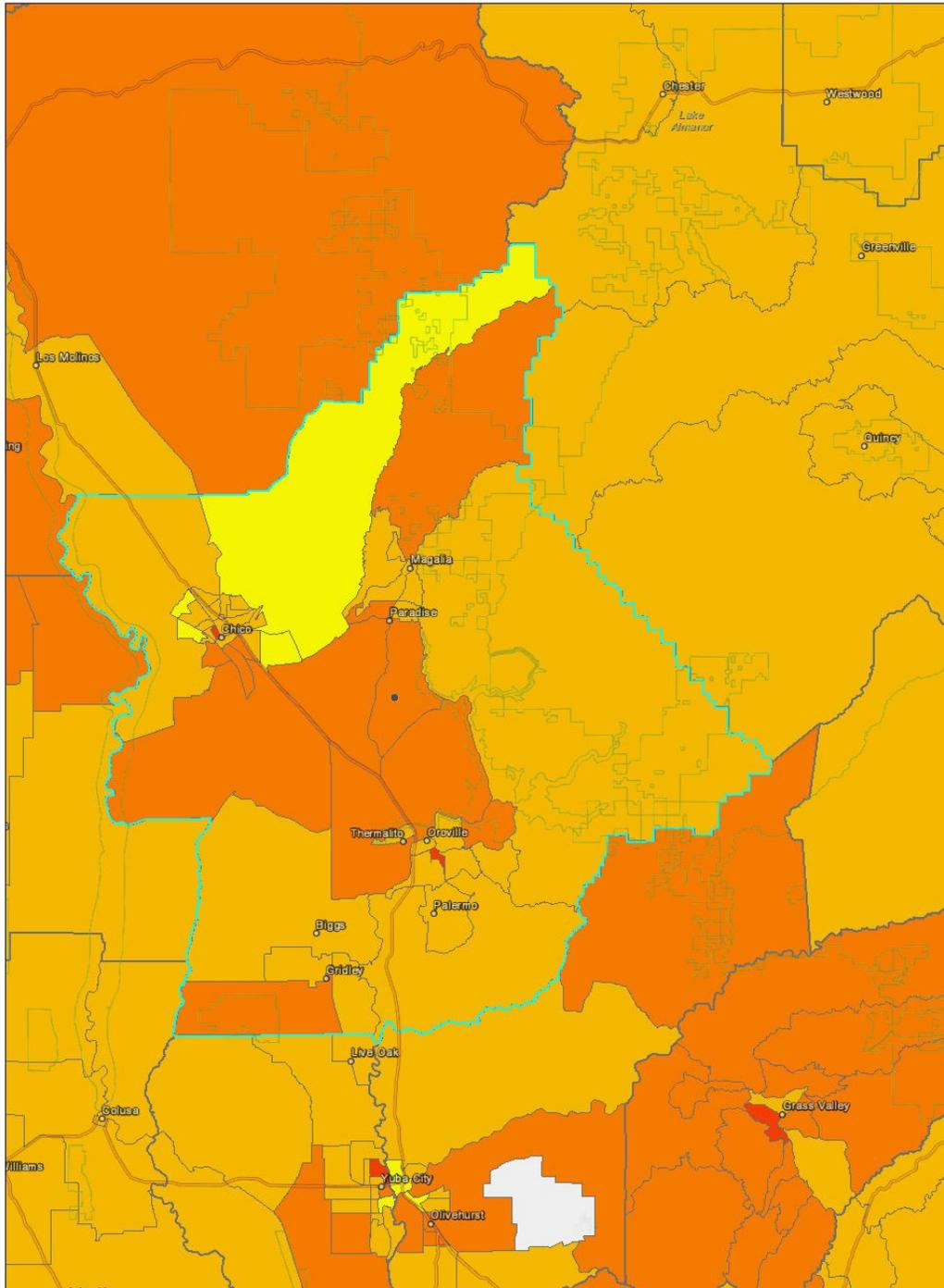
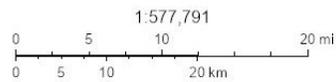

Figure 19.5: Butte County, Overpayment by Owners Map, 2019



3/28/2022, 3:10:08 PM

- County Boundaries
- (R) Overpayment by Home Owners (ACS, 2015 - 2019) - Tract
- < 20%
- 20% - 40%
- 40% - 60%
- 60% - 80%



Esri, HERE, Garmin, (c) OpenStreetMap contributors, and the GIS user community  
Esri, HERE, Garmin, © OpenStreetMap contributors, and the GIS user community

CAHCD

### ***Overpayment by Renters***

The map, “*Figure 19.6: City of Oroville, Overpayment by Renters, 2019*” depicts the number of households that pay 30% or more of their income toward the cost of renting a home. The map indicates that most renters in the City are paying more than 30% of their income toward the cost of renting a home. An estimated 40-60% of renters residing in areas that are shaded dark orange pay more than 30% of their income toward housing costs. This includes Census Tracts 25, 29, 30.01 and 33. An estimated 60-80% of renters residing in areas that are shaded red pay more than 30% of their income toward housing costs, which includes Census Tracts 27, 28, 30.01, and 37.

The map, “*Figure 19.7: Butte County, Overpayment by Renters Map, 2019*” depicts the percentage of renter households for whom gross rent (contract rent plus tenant-paid utilities) is 30% or more of household income. Household income is based on earnings in the past 12 months prior to the survey. Generally, the eastern and western parts of the county have 20-40% of renter households with overpayment. The more populated census tracts near communities, cities, and towns have 40-60% or 60-80% of renter households with overpayment. Only the census tract east of Oroville has less than 20% of renter households with overpayment (*HCD AFFH Data Resources and Mapping Tool: 2015-2019 American Community Survey*).

Figure 19.6: City of Oroville, Overpayment by Renters, 2019

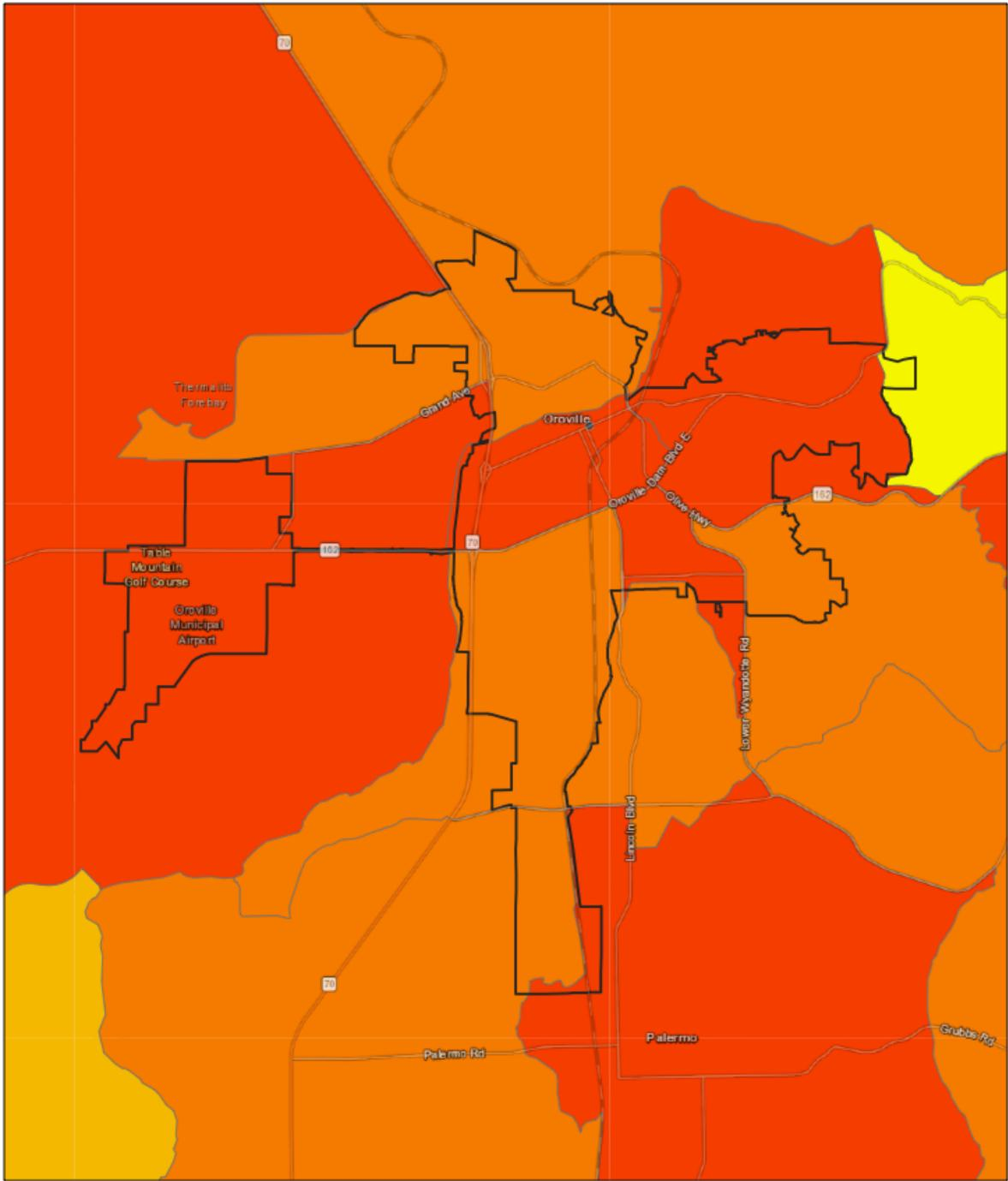

11/8/2021, 11:06:14 AM

City/Town Boundaries

(R) Overpayment by Renters (ACS, 2015 - 2019) - Tract

- < 20%
- 20% - 40%
- 40% - 60%
- 60% - 80%

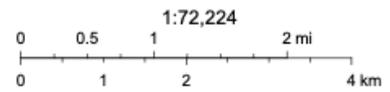
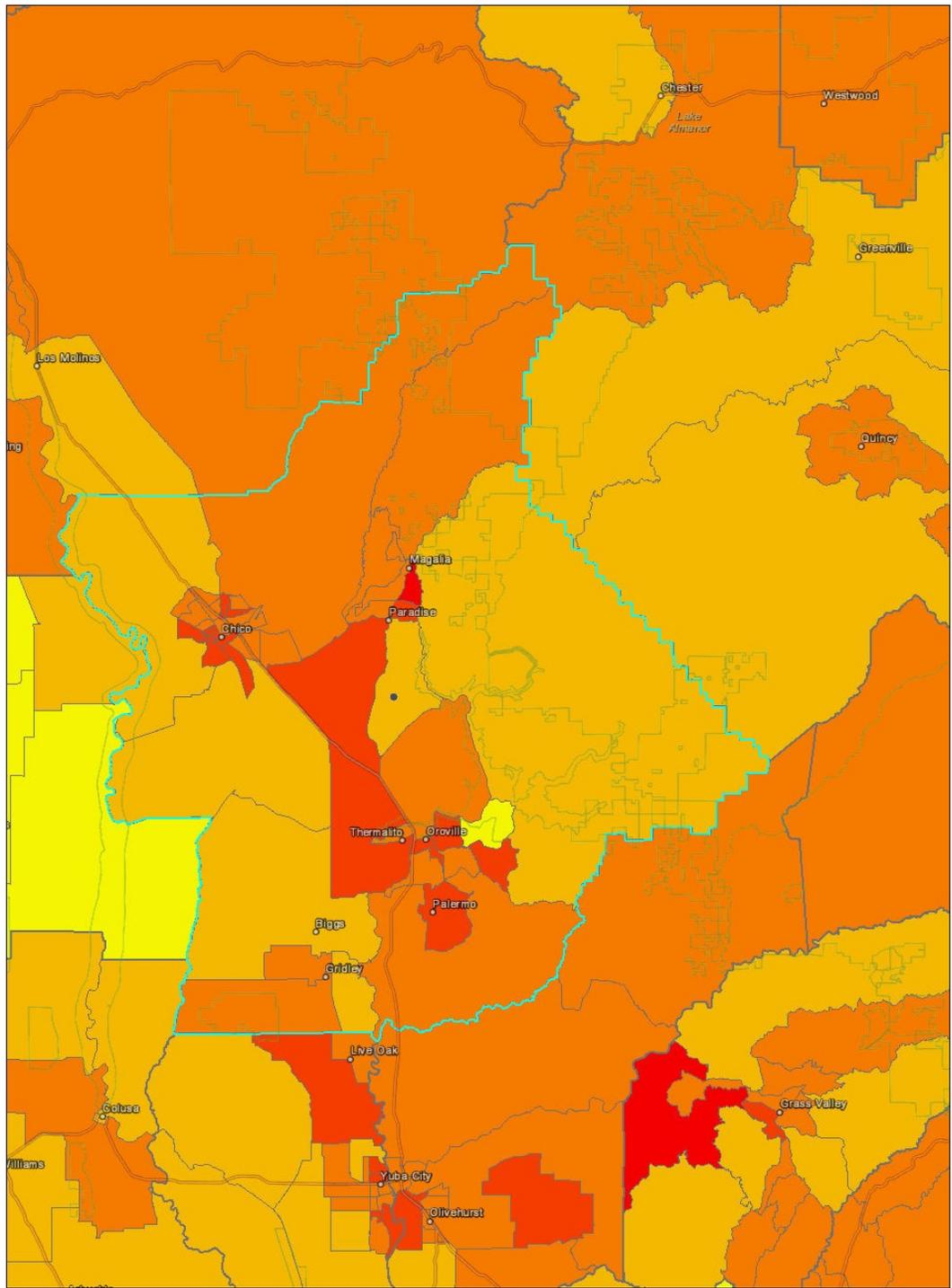

Figure 19.7: Butte County, Overpayment by Renters Map, 2019



3/28/2022, 3:10:57 PM

- County Boundaries
- (R) Overpayment by Renters (ACS, 2015 - 2019) - Tract
- < 20%
- 20% - 40%
- 40% - 60%
- 60% - 80%
- > 80%

1:577,791  
0 5 10 20 mi  
0 5 10 20 km

Esri, HERE, Garmin, (c) OpenStreetMap contributors, and the GIS user community  
Esri, HERE, Garmin, © OpenStreetMap contributors, and the GIS user community

CAHCD

## Homelessness

The following tables depict point-in-time counts of all individuals experiencing homelessness and point-in-time counts of unsheltered individuals experiencing homelessness.

Figure 20: Butte County, Point in Time Count Results, 2009-2019 depicts the total number of individuals experiencing homelessness in jurisdictions within Butte County from 2009 to 2019. From 2009 to 2019, Oroville has experienced steady increases in the number of residents experiencing homelessness, peaking at 713 individuals in 2017. This is equivalent to a 14% increase in homelessness in the last decade. Oroville has the second largest number of people experiencing homelessness in Butte County. Due to impacts of the Camp Fire in November 2018, outreach efforts during the 2019 yielded fewer volunteers and fewer surveys completed than previous efforts. The decrease in the number of individuals counted during 2019 could be due to fewer volunteers, rather than a decrease of people experiencing homelessness.

Figure 20: Butte County, Point in Time Count Results, 2009-2019

Jurisdiction	2009	2010	2011	2013	2015	2017	2019	'09-'19 % Change
Chico	668	865	1043	804	571	1096	864	29%
Oroville	364	386	545	579	390	713	415	14%
Paradise, Magalia, and other Ridge Communities	62	83	71	89	49	120	21	-471%
Gridley and Biggs	2	79	97	65	36	28	23	1050%
Other	10	9	16	16	81	26	0	-100%
	1106	1422	1772	1553	1127	1983	1323	20%

Source: Butte County Continuum of Care

Figure 20.1: Butte County, Point in Time Count Unsheltered Results, 2009-2019 depicts the number of unsheltered individuals experiencing homelessness in jurisdictions within Butte County from 2009 to 2019. Oroville experienced a steep increase of 116% in the number of individuals experiencing unsheltered homelessness from 2009 to 2019. In 2019, 80% of individuals experiencing homelessness were unsheltered.

Figure 20.1: Butte County, Point in Time Count Unsheltered Results, 2009-2019

Jurisdiction	2011	2013	2015	2017	2019	'11-'19 % Change
Chico	304	267	147	433	454	49%
Oroville	154	173	100	236	333	116%
Paradise, Magalia, and other Ridge Communities	28	19	8	61	15	-46%
Gridley and Biggs	50	12	20	10	23	-54%
Other	4	8	8	5	0	-100%
	540	479	283	745	825	53%

Source: Butte County Continuum of Care

### **Mobile Home Parks**

The map, "City of Oroville, Mobile Home Parks, 2019" depicts the location of mobile parks within the City. The map indicates that mobile home parks are dispersed throughout the City and surrounding areas.

Figure 21: City of Oroville, Mobile Home Parks, 2019

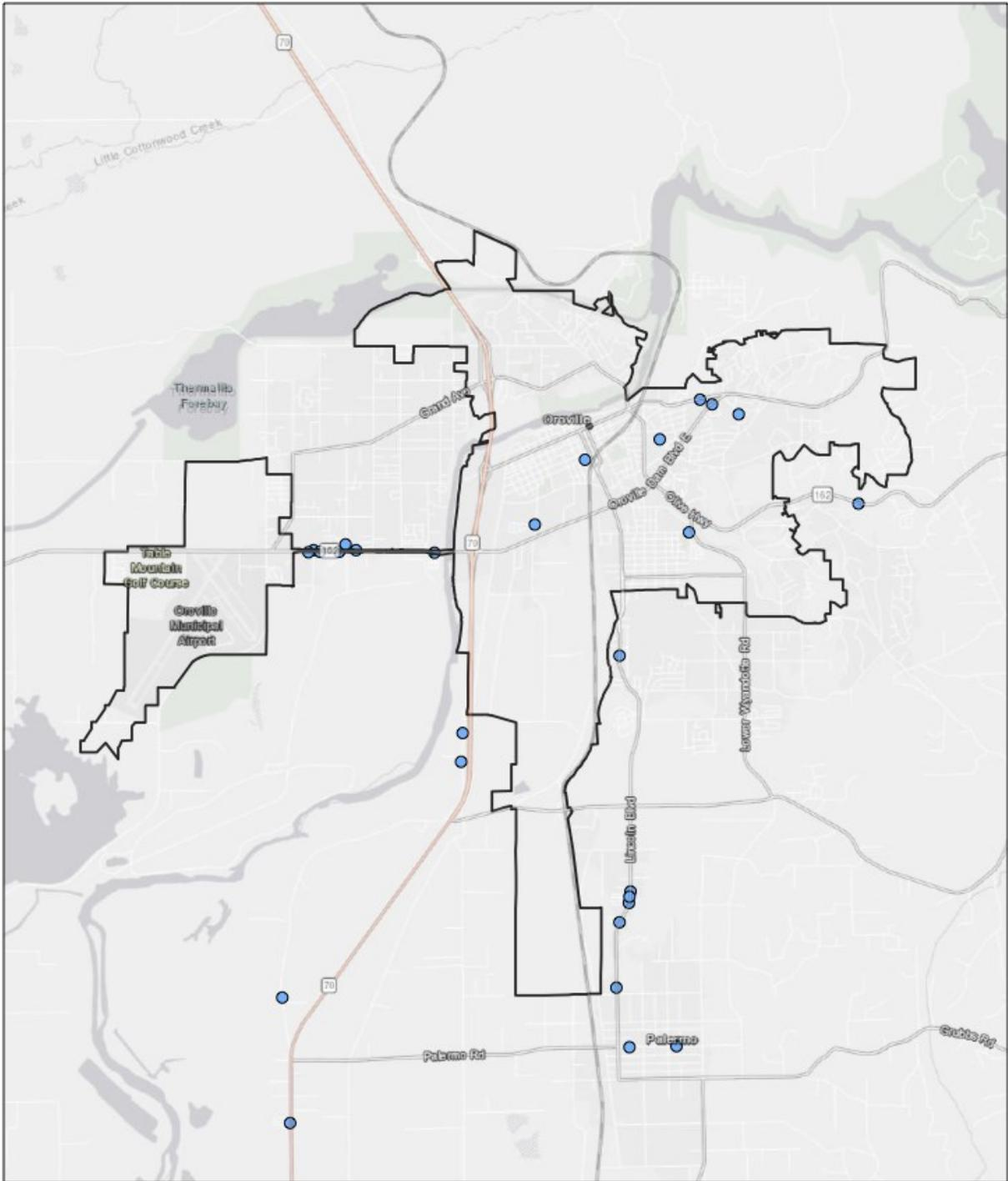

11/8/2021, 11:09:31 AM

- City/Town Boundaries
- (A) Mobile Home Parks (HIFLD, 2018)

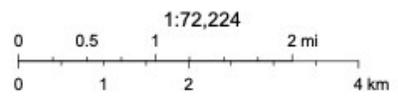

## **Local Data and Knowledge**

Local data and knowledge is collected through interviews with regional stakeholders whose service areas include the City of Oroville and reports that discuss the 2020 North Complex Fire and the 2018 Camp Fire in Butte County.

### **City of Oroville**

On October 13, 2021, the authors conducted an online interview with three staff members from the City of Oroville over Zoom. The City commented that there is a shortage of market-rate, executive housing for government and hospital staff as well as a shortage of rental units, particularly single-family units for all income levels. In addition, a significant number of units do not meet health and safety standards and need rehabilitation. Rents are relatively high in the region, and many residents do not qualify for housing based on income or credit. To meet these diverse needs, the City is interested in encouraging mixed income development.

Despite the constraint on available housing, the City houses a significant number of 2018 Camp Fire and 2020 North Complex Fire survivors from the Town of Paradise and Berry Creek communities. Many are still staying in hotels, while others are occupying single-family homes and are settling in permanently. The City is experiencing continuous impacts from the fires. Home insurance costs have increased by \$6,000-\$8,000 annually and many residents are still living in RVs at local campgrounds, empty lots, and rural parts of the City. Many more residents are unable to secure homeowner's insurance, which makes it difficult to qualify for a mortgage and purchase a home.

### **Youth for Change**

On October 19, 2021, the authors conducted a phone interview from a staff member at Youth for Change, which is a nonprofit that provides services, support, and treatment to children and families in Butte, Sutter-Yuba, Glenn, Shasta, and Trinity Counties. The staff member interviewed works with young adults from 18-24 years that are unhoused. Youth for Change has an estimated 40 active cases of unhoused young adults in Butte County at the time of the interview.

Staff indicated that clients may have difficulty with life skills and are living with severe mental illness, substance addiction, and trauma which may inhibit their ability to secure housing. Clients have difficulty applying for or demonstrating eligibility due to lack of time, education, resources, or mental disability. Staff provides administrative services to assist clients in applying for social service programs, legal identification documentation, Community Housing

Improvement Program, and health services in addition to providing direct transportation, career-building, education, and mental health services.

Clients have difficulty finding housing that fits their needs and affordability, which includes one-bedroom or studio apartments and large homes with three or more bedrooms that can be shared by multiple tenants.

### ***Other Relevant Factors***

This section considers the impacts of fire disasters on housing in the City of Oroville. The analysis primarily focuses on the impacts of the North Complex Fire that occurred in 2020 and the Camp Fire that occurred in 2018.

#### **2020 North Complex Fire**

According to the Incident Information System (InciWeb), the North Complex Fire began on August 17, 2020 and continued for several months, burning a total of 318,935 acres. The incident resulted in 16 deaths and damaged 2,455 structures.

The fire destroyed homes, businesses, and public buildings in the Berry Creek community, east of the City of Oroville, where many residents currently live in campers, tents, and RVs. Residents who are interested in rebuilding their town face high building and permitting costs, criminal activity in the area, and a perceived lack of assistance from the county government and outside agencies. Local data and knowledge indicate that many fire survivors continue to experience precarious housing situations and challenges with mental health such as post-traumatic stress disorder. Staff at the City indicated that many survivors of the fire have relocated in Oroville.

Rebuilding requires coordination with multiple Butte County departments, the Federal Emergency Management Agency, CalFire, and Pacific Gas & Electric Company (PG&E). Stricter State regulations that ensure homes are more resistant to fire and increases in the costs of building materials are driving up costs. In addition, residents must pay to clean up toxic debris and install power poles. The costs to insure homes have been greatly inflated. Residents could benefit from waived permit fees and assistance in development and permitting processes. (*"The Forgotten Fire?"* Ken Smith, Sacramento News & Review, October 2021)

## 2018 Camp Fire

Most data for this section are from two studies: 1. The Impacts of the Camp Fire Disaster on Housing Market Conditions and Housing Opportunities in the Tri-County Region produced by North Valley Community Foundation, a local community foundation; and 2. The Camp Fire Regional Economic Impact Analysis produced by 3CORE, a local economic development organization. These two studies, the former on housing impacts and the latter on economic impacts, focus on the tri-county region of Butte, Glenn, and Tehama Counties. This section also includes related data from a local non-profit.

### **The Impacts of the Camp Fire Disaster on Housing Market Conditions and Housing Opportunities in the Tri-County Region, North Valley Community Foundation, September 2020**

Prior to the 2018 Camp Fire, the tri-county region of Butte, Glenn, and Tehama Counties was already experiencing housing challenges including rising housing costs, rising building costs, low vacancies, limited workforce housing, lack of affordable housing production, and limited types of housing, coupled with economic challenges of slow wage growth, limited number of higher paying jobs, and challenges attracting and retaining employees due to the cost of housing.

The COVID-19 pandemic has threatened the tri-county region in several ways. The medical system is overburdened, residents are spending less money, stores are closing, housing construction has reduced or slowed, and homelessness is increasing, which is adding to the number of residents in precarious economic conditions.

After the 2018 Camp Fire, the tri-county region experienced additional housing challenges including lack of available housing inventory, record high rental rates and housing costs, insufficient assistance for fire survivors, and lack of insurance or underinsurance for many residents. Disaster case management intake records from Butte-Glenn 211 and the Camp Fire Collaborative illustrate unmet needs for fire survivors experiencing homelessness or in precarious housing situations. A substantial surge in home prices and monthly rent rates in the tri-county region in the six months following the Camp Fire disproportionately affected senior households – single people and couples – who had lived in older, lower-cost housing in the burn scar of Concow, Magalia, Paradise, Yankee Hill, and surrounding communities. These households experienced challenges finding homes within their budgets that matched the needs of their families. Butte County's limited housing inventory went to near record lows and home prices in the County went up 46.7% from November 2018 to September 2019.

There is a shortage of affordable and market-rate multi-family units in the tri-county region. The Housing Authority of the County of Butte (HACB) which also serves Butte

County, had a waitlist of 300 households for Butte and Glenn Counties combined prior to the Camp Fire. Openings for available affordable units are limited and the waitlist increased to over 2,800 households in August 2019. The City of Willows in Glenn County, the City of Oroville in Butte County, and the Cities of Corning and Red Bluff in Tehama County tend to attract more demand for market-rate single-family development activity rather than market-rate multi-family development activity.

There is site availability in the tri-county region for large-scale projects. However, developers express challenges for moving projects forward due to high development costs relative to household incomes, including the needed infrastructure required to build and the imbalance of what homes can be delivered and what homebuyers can afford. Additional housing solutions in the region include alternative building techniques such as modular options; manufactured homes; Accessory Dwelling Units (ADUs); tiny homes; better financing options for alternative housing types; and community land trusts, housing trusts, and private bonds.

#### **The Camp fire Regional Economic Impact Analysis, 3CORE, January 2021**

The tri-county region of Butte, Glenn, and Tehama Counties is predominantly rural with an economy propelled by agriculture and related activities such as processing, packaging, and wholesale trade of row and field crops, orchard and tree products, and livestock. Short-term growth projections for Butte County expect employment gains to be centered in agriculture, manufacturing, and leisure.

The 2018 Camp Fire resulted in substantial inter-regional and extra-regional population shifts. Residents displaced by the Camp Fire relocated primarily to Chico and Oroville in Butte County and to a lesser extent, Glenn and Tehama Counties. Unincorporated areas of Butte County and the City of Oroville experiences larger-than-average population increases and noted nominal increases related to housing demand, business activity, and traffic impacts.

The study concludes that based on available information, the Camp Fire resulted in the loss of many middle-income workers who are unlikely to return to the region. This may result in a demographic distribution that is skewed to lower- and higher-income groups. The study suggests the key to replacing workers and re-balancing income groups is the ability to produce new, affordable housing in the region.

**Butte-Glenn 211 Informational and Referral Data, July 2021**

“Figure 21.1: Butte-Glenn 211, Camp Fire Contacts and Referred Services Data Table, November 2018 to October 2021” depicts information on the number of Camp Fire contacts and referred services in Butte-Glenn 211’s database system. Butte-Glenn 211 is an information and referral non-profit agency serving Butte and Glenn Counties by connecting people with assistance services. From the time period of November 1, 2018, to October 31, 2021, the number of referred services to Camp Fire contacts who contacted Butte-Glenn 211 by phone from Butte County was 27,134. The total number of Camp Fire contacts to Butte-Glenn 211 originating from Butte County was 23,832 and the total number of Camp Fire contacts from all counties and states was 34,892 (*Butte-Glenn 211, November 2021 Email Correspondence*). This data illustrates the magnitude of the impact of the Camp Fire on Butte County residents. Over 30,000 people contacted Butte-Glenn 211 for assistance during and after the Camp Fire, and Butte-Glenn 211 referred over 25,000 services to Camp Fire phone callers from Butte County.

**Figure 21.1: Butte-Glenn 211, Camp Fire Contacts and Referred Services Data Table, November 2018 to October 2021**

Time Period	Number of Referred Services to Camp Fire Phone Callers Originating from Butte County	Total Number of Camp Fire Callers Originating from Butte County	Total Number of Camp Fire Callers to 211 (all counties/states)
November 1, 2018 to October 31, 2021	27,134	23,832	34,892

Source: *Butte-Glenn 211, November 2021 Email Correspondence*

“Figure 21.2: Butte County Department of Employment and Social Services, Financial Assistance Provided to Camp Fire Survivors Table, January 2019 to July 2021” depicts the dollar amount of assistance the Butte County Department of Employment and Social Services provided to Camp Fire survivors by assistance type. Vehicles and RVs, home repairs/rebuilds, rent and mortgage, and vehicle items/RV repair were the assistance types with the largest amount of assistance provided in dollars. These findings illustrate that both temporary and permanent housing was a significant need following the Camp Fire. Butte County Department of Employment and Social Services (Butte County DESS) administers employment and social services to Butte County residents. Butte County

DESS provided its “Camp Fire Relief Grant Final Report, January 2019 through July 2021” for use in this report on October 5, 2021 via email correspondence. In January 2019, North Valley Community Foundation provided a one-million-dollar grant to Butte County DESS to assist 2018 Camp Fire survivors with housing, mental health, and replacing belongings.

**Figure 21.2: Butte County Department of Employment and Social Services, Financial Assistance Provided to Camp Fire Survivors Table, January 2019 to July 2021**

Assistance Type	Total Assistance Provided in Dollars
Vehicles and RVs	\$289,978
Home Repairs/Rebuilds	\$214,806
Rent and Mortgage	\$170,031
Vehicle Items/RV Repair	\$165,540
Property Replacement	\$69,747
Shelter	\$55,166
Utilities	\$12,703
Deliveries	\$11,716
Miscellaneous	\$10,192
<b>Total</b>	<b>\$999,968.70</b>

*Source: Butte County Department of Employment and Social Services, Camp Fire Relief Grant Final Report, January 2019 to July 2021*

### The Camp Fire Collaborative (CFC)

The Camp Fire Collaborative (CFC) is based in Chico, California and is a community collaboration made up of 50+ nonprofits, private, and public organizations working to address unmet needs of Camp Fire survivors in Butte County. It was formed as a Long-Term Recovery Group after the 2018 Camp Fire. The CFC helps to coordinate disaster case management (DCM) currently provided by five organizations in the County. In an interview for this report on October 25, 2021 staff commented that Butte County has the

greatest need for affordable housing, accessible housing, and senior housing following the Camp Fire. The DCM works mostly with seniors with fixed incomes due to the demographics on The Ridge (Magalia, Town of Paradise) prior to the Camp Fire. Staff noted barriers to housing include access to and navigating internet and phone communication as well as temporary address changes, a lack of housing inventory, and units that will accept pets. There are Camp Fire survivor households that have been displaced multiple times since the fire and continue to couch surf. Some Camp Fire survivors want to re-settle in the burn scar area to stay close to resources, medical care, and supports systems. Relocating to the Cities of Chico or Oroville is not ideal for them.

When asked about specific barriers that people of color or people with disabilities experience in accessing housing, staff commented that people of color and people who speak English as a second language were a small population on The Ridge and in the DCM caseload. Barriers experienced by these populations include concerns about citizenship status and accessing or accepting resources that may jeopardize information like immigration status. Staff noted that people with disabilities who are Camp Fire survivors and experiencing homelessness is uniquely challenging for long-term recovery. Survivors may be living in RVs and trailers that are not accessible, and there are not many options for accessible housing on The Ridge. Mobile home parks on The Ridge were destroyed in the Camp Fire.

When asked about ongoing impacts of the Camp Fire on the City of Oroville, staff noted that a significant number of clients relocated to Oroville, which resulted in increases in housing costs and decreases rental unit availability in the City due to the significant increase in housing demand in that region. Staff commented that their clients tend to be living in the Cities of Oroville, Corning, Red Bluff, or Redding instead of Chico or Biggs/Gridley, due to the availability of units, and size and price of housing. Many RV campgrounds are now being used as permanent housing for Camp Fire survivors who have a RV/trailer.

Staff noted that the City needs affordable rental housing, family units, and mobile home parks. Many clients have funding for a mobile home, but cannot afford to park it because rents increased from \$300-500/month prior to the fire to \$600-800/month after the fire.

### ***Summary of Findings***

Most residents in the City have a low income. A 2019 survey indicated that more than half of the population in the City of Oroville has a household income of less than \$34,999, which means more than half of the population can only afford a studio. Asian residents are significantly less likely to own a home than White and Hispanic or Latino residents.

In Census Tract 28, 60-80% of residents live in rental units which is the largest concentration of rental units in the entire City. In Census Tracts 25, 29, 30.01, and 30.02, 40-60% of residents live in rental units, which is greater than most other regions of the County. About 70% of households with one of four Housing Problems or one of four Severe Housing Problems are renters. In Census Tracts 29 and 30.01, the level of overcrowding is double that of the State average. The majority of homeowner households are paying greater than 30% of their income toward housing costs, but 60-80% of homeowners pay more than 30% of their income toward housing costs in Census Tract 30.01 and 40-60% of homeowners in Census Tracts 25 and 37. In comparison to Butte County, households in the City of Oroville are more likely to be overcrowded and overpaying.

Most renters in the City pay more than 30% of their income toward housing costs. However, 60-80% of renters residing in areas that are shaded red in Figure 19.4 Overpayment by Renters pay more than 30% of their income toward housing costs, which includes Census Tracts 27, 28, 30.01, and 37. Naturally occurring affordable housing such as mobile home parks are dispersed evenly throughout the City. Homelessness has increased by 14% in the last decade, and the City of Oroville has the second largest population of individuals experiencing homelessness in Butte County. Of those individuals, 80% are unsheltered.

The City commented that there is a shortage of market-rate housing, rental units for all income levels, and many units that need rehabilitation. The City is interested in mixed-income development. Many fire survivors have settled in the region. Increased home insurance costs or inability to obtain homeowners insurance is making it difficult for residents to purchase a home. Staff from Youth for Change also indicated that low-income tenants have trouble securing small units and qualifying for housing.

Furthermore, over 30,000 Camp Fire survivors needed assistance and contacted Butte-Glenn 211. Butte-Glenn 211 referred over 25,000 services to Camp Fire survivors in Butte County. The Butte County Department of Employment and Social services provided over one million dollars in assistance for vehicles/RVs, home repairs/rebuilds, vehicle/RV repair, property replacement, shelter, utilities, deliveries, and other forms of assistance.

The shortage of housing in the City of Oroville was exacerbated by the Camp Fire, which destroyed naturally occurring affordable housing in the tri-county region of Butte, Glenn, and Tehama Counties and disproportionately impacted low-income and senior residents. Many residents have relocated throughout the region, but some are still unable to find housing, which is resulting in increases in overcrowding and displacement. Rents and housing costs reached record highs after the Camp Fire, which added to the number of households experiences precarious housing conditions. Housing prices in Butte County have increased by more than \$100,000 because of the Camp Fire. Fires continue to haunt the region. The North Complex Fire destroyed homes, businesses, and public building in the Berry Creek community, where many residents are living in temporary housing solutions such as RVs and campers.

Interviews with local agencies concluded that single residents, seniors, fixed-income residents, and low-income residents are most impacted by rising housing costs. Community organizations would like to see the City take an active role in promoting and facilitating that development of mixed-density, mixed-use, market-rate, and affordable housing as well as housing that meets the needs of protected classes, especially those experiencing homelessness, mental health conditions, or disabilities. Community organizations requested improved permitting and development processes, such as flexible allowances, mixed-use and high-density zoning, and incentives for infill development.

## DEMOGRAPHICS

---

### Population

As of January 1, 2021, the population of Oroville was estimated at 17,863 by the California Department of Finance. “Figure 22: Population Growth, City of Oroville and Butte County, 2016-2021” shows that the population of Oroville declined by 224 persons between 2016 and 2021, with an increase of 2,707 persons between 2016 and 2019 and a decrease of 2,931 persons from 2019 to 2021. Butte County’s population declined by 21,317 between 2016 and 2021, with an increase of 2,112 persons between 2016 and 2018 and a decrease of 23,429 between 2018 and 2021. The change in population trends for Butte County occurred around the same time as the Camp Fire at the end of 2018. The population of Oroville decreased by about 1.2%, and the population of Butte County decreased by about 10%, from 2016 to 2021.

Figure 22: Population Growth, City of Oroville and Butte County, 2016-2021

	2016	2017	2018	2019	2020	2021	Average Annual Change
<b>Oroville</b>	18,087	18,101	18,075	20,794	18,888	17,863	
<b>Butte County</b>	223,986	225,468	226,098	220,855	208,951	202,669	
<b>Oroville-Yearly Change</b>	--	+14	-26	+2,719	-1,906	-1,025	
<b>Butte-Yearly Change</b>	--	+1,482	+630	-5,243	-11,904	-6,282	5,109

Source: California Department of Finance, 2021

Figure 22: Population Growth Chart, City of Oroville and Butte County, 2016-2021

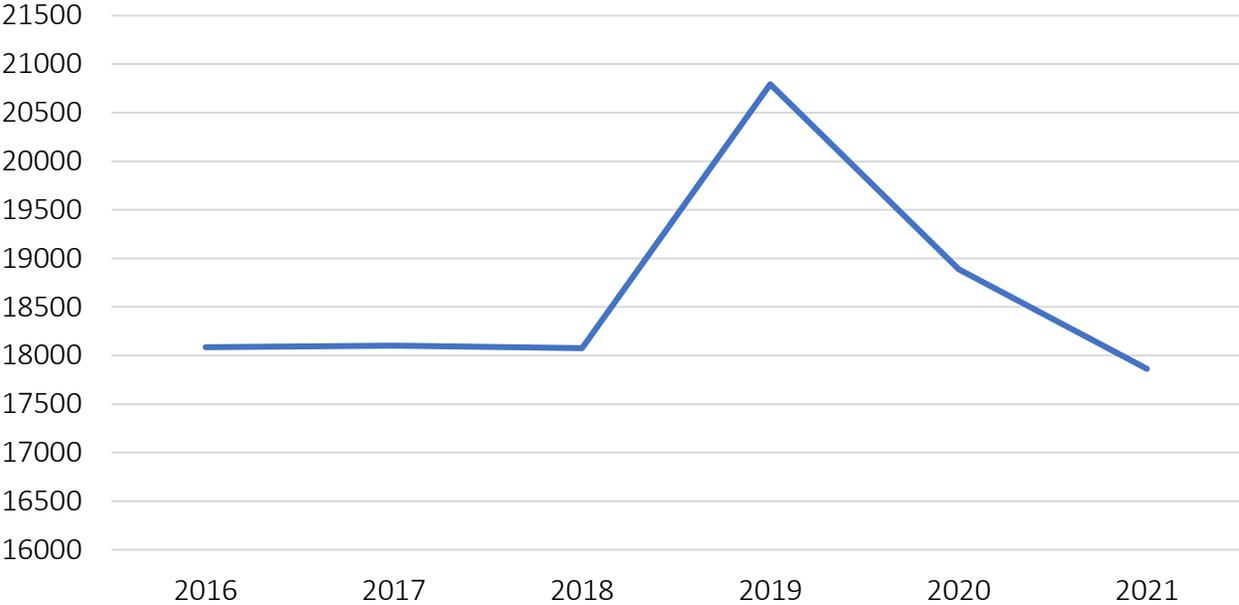

“Figure 22.2: Population Forecast, City of Oroville and Butte County, 2020-2040” shows projected population growth as forecast by the Butte County Association of Governments in their Post Camp Fire Study published in 2020. It is forecast that Oroville will increase in population by 2,017 between 2020 and 2040, which is a much slower growth rate than for Butte County, which is projected to increase by 51,727 over this period. This projection model assumes that most of Butte County’s growth will occur in the Paradise and Magalia area as those communities rebuild from the Camp Fire.

Figure 22.2: Population Forecast, City of Oroville and Butte County, 2020-2040

	2020	2025	2030	2035	2040	2020-2040 Change	2020-2040 Percent Change
<b>Oroville</b>	19,440	19,621	20,052	20,550	21,457	2,017	10.4%
<b>Butte County</b>	210,291	230,056	241,333	251,266	262,018	51,727	24.6%

Source: Butte County Association of Governments, Post Camp Fire Study, 2020

### Population by Age

“Figure 22.3: Population by Age, City of Oroville, 2019” shows the distribution of the population by age for Oroville. Note that this data has a different source (U.S. Census) and time period (2019) than the data used for the Population Growth figures above. The largest 20-year cohort is 20 to 39 years at 30.3%. The largest 10-year cohort is 20 to 29 years old at 15.7% of the population, closely followed by under 10 years old at 15.6% of the total population. About one in five Oroville residents is over 60 years old at 20.8% The median age for Oroville is 34 years old, which is younger than the statewide median age of 36.5 years old.

Figure 22.3: Population by Age, City of Oroville, 2019

Age	Persons	Percent of Total
Under 10 years	3,037	15.6%
10 to 19 years	2,251	11.6%
20 to 29 years	3,043	15.7%
30 to 39 years	2,832	14.6%
40 to 49 years	1,809	9.3%
50 to 59 years	2,254	11.6%
60 to 69 years	2,040	9.9%
70 to 79 years	1,346	6.9%
80 years and over	781	4.0%
Total		

Source: U.S. Census Bureau, 2015-2019 American Community Survey

### EMPLOYMENT

Total employment in Oroville in December 2020 was 5,500, as estimated by the California Employment Development Department. Employment has ranged between 5,500 and 6,400 from

2010 to 2020. The Labor Force, which is the population that is actively seeking employment, has ranged between 6,100 and 6,800. The unemployment rate decreased from 16.2% in 2010 to 5.3% in 2018, before rising again to 9.8% in 2020. Trends in the unemployment rate have followed national and state trends. (Figure 23: Total Employment and Unemployment, City of Oroville 2010-2020) and (Figure 23.1: Unemployment Rate Chart, City of Oroville, 2010-2020)

**Figure 23: Total Employment and Unemployment, City of Oroville 2010-2020**

	Labor Force	Employment	Unemployment	Unemployment Rate
<b>2010</b>	6,600	5,500	1,100	16.2%
<b>2011</b>	6,400	5,400	1,000	15.8%
<b>2012</b>	6,400	5,500	900	14.1%
<b>2013</b>	6,400	5,700	800	11.9%
<b>2014</b>	6,400	5,800	600	10.1%
<b>2015</b>	6,400	5,800	500	8.3%
<b>2016</b>	6,800	6,300	500	7.3%
<b>2017</b>	6,800	6,400	400	5.6%
<b>2018</b>	6,100	5,800	300	5.3%
<b>2019</b>	6,400	6,100	400	5.6%
<b>2020</b>	6,100	5,500	600	9.8%
<b>Ave. Annual Percent Change</b>				1.54%

Source: Employment Development Department, 2021

Figure 23.1: Unemployment Rate Chart, City of Oroville, 2010-2020

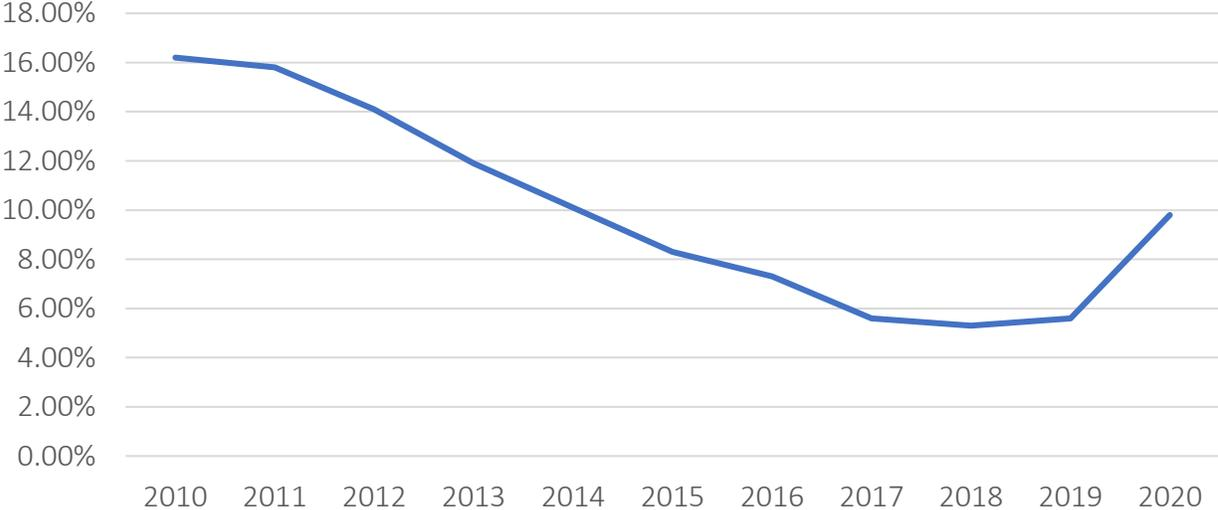

“Figure 23.2: Employment by Industry, City of Oroville, 2019” shows employment by industry for Oroville residents. The Educational services, and health care and social assistance Industry has significantly more employment than any of the other industries, with 24% of all jobs. The industries with the next largest shares of employment are Arts, entertainment, and recreation, and accommodation and food services (9.4%); Manufacturing (9.4%); Finance and insurance, and real estate and rental and leasing (9.2%); and Professional, scientific, and management, and administrative and waste management services (8.1%).

Figure 23.2: Employment by Industry, City of Oroville, 2019

Industry	Estimate	Percent
Civilian employed population 16 years and over	3,565	100%
Agriculture, forestry, fishing and hunting, and mining	94	2.6%
Construction	183	5.1%
Manufacturing	336	9.4%
Wholesale trade	64	1.8%
Retail trade	327	9.2%
Transportation and warehousing, and utilities	161	4.5%
Information	11	0.3%
Finance and insurance, and real estate and rental and leasing	329	9.2%
Professional, scientific, and management, and administrative and waste management services	289	8.1%
Educational services, and health care and social assistance	856	24%
Arts, entertainment, and recreation, and accommodation and food services	335	9.4%
Other services, except public administration	200	5.6%
Public administration	380	10.7%

Source: U.S. Census Bureau, 2015-2019 American Community Survey

## HOUSEHOLD CHARACTERISTICS

### Household Income

“Figure 24: State Income Categories, Butte County, 2021” shows household incomes by category and percent of area income for Butte County, as calculated by the State Department of Housing and Community Development. These income categories are referenced in the RHNA Sites Inventory that is part of this Housing Element and are also used in setting target rents for affordable housing programs and projects.

Figure 24: State Income Categories, Butte County, 2021

Maximum Income by Persons in the Household						
Income Category	% of Area Median Income	1	2	3	4	5
Extremely Low	0-30%	\$14,640	\$16,740	\$18,840	\$20,910	\$22,590
Very Low	31-50%	\$24,400	\$27,900	\$31,400	\$34,850	\$37,650
Low	51-80%	\$39,040	\$44,640	\$50,240	\$55,760	\$60,240
Median	100%	\$48,800	\$55,800	\$62,800	<b>\$69,700</b>	\$75,300
Moderate	81-120%	\$58,560	\$66,960	\$75,360	\$83,640	\$90,360

Source: California Department of Housing and Community Development, 2021 State Income Limits

“Figure 24.1: Household Income, City of Oroville, 2019” shows the number of households in Oroville by income category. The largest income category is \$25,000 to \$34,999 annually at 18.4%, followed by \$50,000 to \$74,999 annually at 18.2%. Almost one-third of households earn less than \$25,000. The median household income is \$34,428, much lower than the statewide median income at \$75,235.

Figure 24.1: Household Income, City of Oroville, 2019

	Number of Households	% of Total
Less than \$15,000	1,000	15.6%
\$15,000 to \$24,999	1,071	16.6%
\$25,000 to \$34,999	1,180	18.4%
\$35,000 to \$49,999	845	13.1%
\$50,000 to \$74,999	1,169	18.2%
\$75,000 to \$99,999	449	7.0%
\$100,000 or more	712	11.1%
<b>Total Households</b>	<b>6,426</b>	<b>--</b>

Source: U.S. Census Bureau, 2015-2019 American Community Survey

“Figure 24.2: Household Income by Housing Tenure, City of Oroville, 2019” shows that the median household income for households in owner-occupied housing units is about twice the median income for households in renter-occupied housing units. The largest income category of households in owner-occupied housing units have incomes from \$50,000 to \$74,999 (23.1%), followed by households with incomes from \$35,000 to \$49,999 (17.4%). The largest income category of households in renter-occupied housing units also have incomes from \$25,000 to \$34,999 (22.7%), followed by households with incomes from \$50,000 to \$74,999 (14.0%). Almost one-half of households in renter-occupied units earn less than \$25,000 (44.4%). This data shows that there are very few renters earning \$75,000 or more (9.9%) compared to households in owner-occupied units (28.4%).

Figure 24.2: Household Income by Housing Tenure, City of Oroville, 2019

Household Income (in past 12 Months)	Owner-occupied Housing Units	Percentage Owner-occupied	Renter-occupied Housing Unit	Percentage Renter-occupied
Less than \$5,000	31	1.1%	128	3.7%
\$5,000 to \$9,999	102	3.5%	195	5.6%
\$10,000 to \$14,999	135	4.6%	409	11.7%
\$15,000 to \$19,999	130	4.4%	431	12.4%
\$20,000 to \$24,999	127	4.3%	383	11.0%
\$25,000 to \$34,999	389	13.2%	791	22.7%
\$35,000 to \$49,999	512	17.4%	333	9.6%
\$50,000 to \$74,999	681	23.1%	487	14.0%
\$75,000 to \$99,999	308	10.5%	140	4.0%
\$100,000 to \$149,999	339	11.5%	110	3.2%
\$150,000 or more	189	6.4%	76	2.2%
Median household income (dollars)	\$52,854			\$26,865
Occupied housing units	2,943	45.8%	3,483	54.2%

Source: U.S. Census Bureau, 2015-2019 American Community Survey

### Housing Tenure

The majority of units in Oroville are renter-occupied, with 3,483 (54.2%). There are 2,943 units in Oroville that are owner-occupied (45.8%). The proportion of renter-occupied housing units in Oroville is similar to the State of California as a whole, for which 55% of units are owner-occupied.

Figure 24.3: Occupied Housing Units by Tenure, City of Oroville, 2019

	Number	Percent
Owner-occupied housing units	2,943	45.8%
Renter-occupied housing units	3,483	54.2%
Total	7,174	--

Source: U.S. Census Bureau, 2015-2019 American Community Survey

### Householder Age

“Figure 24.4: Tenure by Age of Householder, City of Oroville, 2019” shows that the largest percentage of owner householders are 55 to 64 years old (24.7%), while only 12.5% of owner households are under 35 years old. Of renter householders, 32.2% are under 35 years old and 51.1% are under 45 years old.

Figure 24.4: Tenure by Age of Householder, City of Oroville, 2019

Householder	Owner-occupied	Pct. of Total	Renter-occupied	Pct. of Total	Total	Pct. of Total
Under 35 years	367	12.5%	1,120	32.2%	1,487	23.1%
35 to 44 years	401	13.6%	659	18.9%	1,060	16.5%
45 to 54 years	327	11.1%	395	11.3%	722	11.2%
55 to 64 years	788	26.8%	643	18.5%	1,431	22.3%
65 to 74 years	516	17.5%	300	8.6%	816	12.7%
75 to 84 years	434	14.7%	295	8.5%	729	11.3%
85 years and over	110	3.7%	71	2.0%	181	2.8%
Total	2,943		3,483		6,426	

Source: U.S. Census Bureau, 2015-2019 American Community Survey

## HOUSING STOCK CHARACTERISTICS

### *Population and Housing Units*

As of January 1, 2021 in Oroville, there were an estimated 7,439 housing units and a population of 17,863, according to the State of California Department of Finance. As shown in “*Figure 25: Population and Housing Units, City of Oroville, 2010 & 2021,*” between 2010 and 2021 Oroville’s population increased by 2,317, while the number of housing units increased by 1,245. The persons per household decreased from 2.60 in 2010 to 2.50 in 2021. The vacancy rate decreased from 8.8% in 2010 to 8.6% in 2021.

**Figure 25: Population and Housing Units, City of Oroville, 2010 & 2021**

Year	Population	Persons in Households	Persons in Group Quarters	Total Housing Units	Vacancy Rate	Person per Household
2010	15,546	14,662	884	6,194	8.8%	2.60
2021	17,863	17,006	857	7,439	8.6%	2.50

*Source: California Department of Finance, 2021*

The overall vacancy rate decreased slightly from 8.8% in 2010 to 8.6% in 2021. The total number of estimated vacancies in 2021 as estimated by the California Department of Finance was 640. Another data point for vacancies is the U.S. Census 2019 American Community Survey. Figure 25.1 below shows vacancies by vacancy status. This data shows 472 vacant rental units (including “For rent”, “Rented, not occupied”, and “For seasonal, recreational, or occasional use” categories) and 276 for-sale units (including “For sale only”, “Sold, not occupied”, and “Other vacant” categories), for a total of 748 vacant units. This estimate is higher than the 640 vacancies estimated by the California Department of Finance for 2021. If the “Rented, not occupied” units are removed from the count, the estimate is 513.

Figure 25.1: Vacancy Status, City of Oroville, 2019

Vacancy Status	Number of Units
For rent	189
Rented, not occupied	235
For sale only	54
Sold, not occupied	0
For seasonal, recreational, or occasional use	48
For migrant workers	0
Other vacant	222
<b>Total Vacant Units</b>	<b>748</b>

Source: U.S. Census, 2014-2019 American Community Survey

### Housing Units by Type

“Figure 25.2: Housing Units by Type, City of Oroville, 2010 & 2021” shows the breakdown of housing units by type as estimated by the State Department of Finance in 2010 and 2021. While just over half of housing units are in single-family detached structures at 53.5%, there has been a significant increase in share of units in single-family attached structures and mobile homes from 2010 to 2021. There is a much greater variety in housing types in Oroville than Butte County as a whole, for which 82.0% of housing units are in single-family detached structures.

Figure 25.2: Housing Units by Type, City of Oroville, 2010 &amp; 2021

Year	Total Housing Units	Single Family Detached Units	Single Family Attached	2-4 Units in Structure	5+ Units in Structure	Mobile Homes
2010	6,194	3,625	221	782	1,187	379
2021	7,439	3,980	802	845	1,310	502
Change	1,245	355	581	63	123	123
Percent Change	20.1%	9.8%	262.9%	8.1%	10.4%	32.5%

Source: California Department of Finance, 2021, E-5 Population and Housing Estimates for Cities

Figure 25.3: Housing Units by Type Chart, City of Oroville, 2010 & 2021

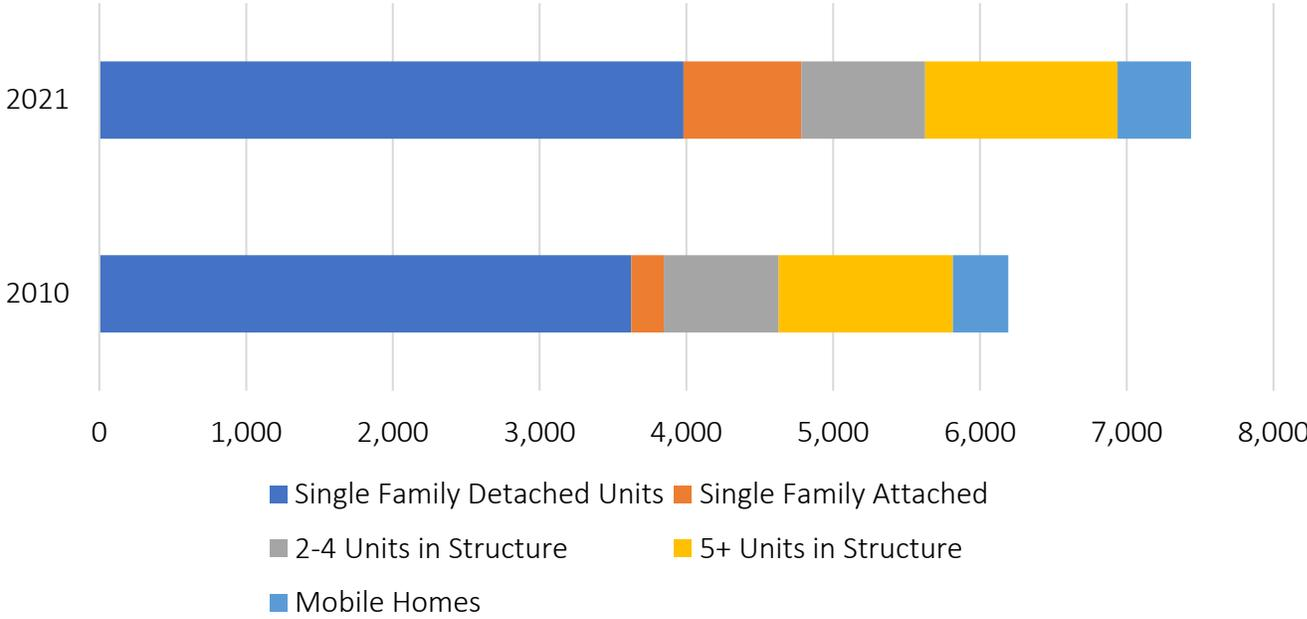

**Overcrowding**

Overcrowding is an important measure to help determine if there is adequate housing stock for the population. “Figure 25.4: Tenure by Occupants per Room, City of Oroville, 2019” identifies the number of units that are considered by the federal government as Overcrowded (more than one occupant per room) and Severely Overcrowded (1.5 or more occupants per room). In 2019, there were an estimated 442 Overcrowded housing units in Oroville, which was 6.9% of all units. There were an estimated 113 Severely Overcrowded housing units estimated, which was 1.8% of all units. (Note that the 6,426 estimated total number of housing units are occupied units rather than total units, from a different source (U.S. Census Bureau) and for a different year (2019) than the estimated number of housing units in “Figure 25.2: Housing Units by Type, City of Oroville, 2010 & 2021.”) There is a significantly larger share of Overcrowded units in Oroville than in Butte County as a whole, in which 3.2% of units were Overcrowded in 2019.

Figure 25.4: Tenure by Occupants per Room, City of Oroville, 2019

Occupants per Room	Owner-occupied	Renter-occupied	Total
0.50 or less occupants per room	2,097	1,764	3,861
0.51 to 1.00 occupants per room	732	1,391	2,123
1.01 to 1.50 occupants per room	86	243	329
1.51 to 2.00 occupants per room	28	64	92
2.01 or more occupants per room	0	21	21
<b>Total</b>	<b>2,943</b>	<b>3,483</b>	<b>6,426</b>
Overcrowded (1.01 or more)	114	328	442
Severely overcrowded (1.5 or more)	28	85	113

Source: U.S. Census Bureau, 2015-2019 American Community Survey

### Housing Conditions

“Figure 25.5: Housing Units by Year Structure Built Chart, City of Oroville, 2019” shows a breakdown of the number of units by the year in which their structure was built. In general, Oroville’s housing stock is older in age, with about three in four units built before 1980. Almost half of Oroville’s units were built between 1950 and 1979 and about one-quarter were built before 1950. This figure shows that construction of residential structures has slowed considerably since 2009, with just 2.2% of all units built in 2010 and later. The large proportion of older units in Oroville indicates a high need for rehabilitation, as many of these units are likely to be in poor condition due to deferred maintenance, as further illustrated by code enforcement data below.

Figure 25.5: Housing Units by Year Structure Built Chart, City of Oroville, 2019

	Units	Percentage
Built 2010 or later	163	2.2%
1980 to 2009	1,688	23.5%
1950 to 1979	3,470	48.4%
1949 or earlier	1,853	25.9%
Total	7,174	--

Source: U.S. Census Bureau, 2015-2019 American Community Survey

Code enforcement data provides another window to housing conditions. A high number of code enforcement cases relative to the overall number of units, or particular trends by year, type of code enforcement, or location of code enforcement may provide indicators of the level of rehabilitation need in the City. Therefore, trends in the number of code enforcement cases and the type of code enforcement involved were analyzed. The City of Oroville provided data for this report. Of the total of 444 substandard housing cases opened between January 1, 2014 and October 4, 2021, 217 of these cases related to the structural integrity of residential buildings, damages caused by flooding, sewer leaks, fire, poor roof conditions, damaged foundations, and cracked walls and floors, as shown in Figure 25.6. This data shows that these types of code enforcement cases peaked in 2016 with 71 cases, and then declined significantly from 2017 to 2021. Single-family housing unit code enforcement cases declined from 38 in 2016 to 12 in 2017, and 7 to 16 from 2018 to 2021. Multi-family housing unit code enforcement cases declined from 24 in 2016 to 7 in 2017, and to just 3-4 cases from 2018 to 2021. Figure 25.6 does not include building violation code enforcement cases. Out of the 408 opened cases in this category, 37 were related to structural integrity of residential structures, damages caused by flooding, sewer leaks, fire, poor roof conditions, damaged foundations, and cracked walls and floors (City of Oroville, October 5, 2021).

Figure 25.6: Code Enforcement Cases for Substandard Housing, City of Oroville, 2014-2021

	Single-family	Multi-family	Total
2014	11	27	38
2015	14	20	34
2016	38	24	71
2017	12	7	19
2018	16	4	20
2019	16	3	19
2020	7	3	10
2021	11	4	15
<b>Total</b>	<b>125</b>	<b>92</b>	<b>217</b>

Source: City of Oroville, 2021

The City of Oroville commissioned a housing conditions survey for South Oroville, which was completed in 2021. This survey encompassed 1,220 units in the South Oroville neighborhood, which is an older low-income neighborhood in the City of Oroville that was recently annexed. Of the surveyed units, 25.9%, or 316 units, were determined to be in need of rehabilitation, with the most common types of deterioration present in roofs, walls or columns, windows, and doors.

The number and proportion of foreclosures are other data points for assessing housing conditions since many foreclosed dwellings have deferred maintenance. Real estate sales data was collected for 2014 through 2021. Over this period, there were only 15 sales reported as “Real Estate Owned”, or through foreclosure, ranging from zero to six in each of the years. Overall, the number of foreclosures from 2014 through 2021 represented 0.3% of all sales in Oroville.

The data reviewed above was used to estimate the number of units in Oroville that are in need of significant rehabilitation. Code enforcement data shows that between January 1, 2014 and October 4, 2021, there were 217 substandard housing cases that related to the structural integrity of residential buildings. Of the building violation code enforcement cases over this period, 37 were related to structural integrity of residential buildings. This totals 254 units

identified by the City of Oroville as in need of significant rehabilitation over the past seven years. In addition, the housing conditions survey of South Oroville found that an estimated 316 units are in need of significant rehabilitation. Adding these two numbers brings the estimate of units in need of rehabilitation in Oroville to 570 units. This is about 11% of the estimated total units built earlier than 1980.

**Housing Production**

“Figure 25.7: Housing Production, City of Oroville, 2014-2020” shows housing production by RHNA income level over the previous Housing Element planning period. The total number of units produced over this period was 224, which was 12.5% of the 2014-2022 RHNA goal for total units. Most of the units produced were in the Above Moderate-Income level.

**Figure 25.7: Housing Production, City of Oroville, 2014-2020**

RHNA Income Level	2014	2015	2016	2017	2018	2019	2020	2021	Total
Very Low		2	8						10
Low	57	4	6			1			68
Moderate									
Above Moderate	14	11	1	3	9	56	52		146
<b>Total</b>	<b>71</b>	<b>17</b>	<b>15</b>	<b>3</b>	<b>9</b>	<b>57</b>	<b>52</b>		<b>224</b>

Source: City of Oroville, 2021

A large number of affordable multi-family residential projects are currently in development. This includes six projects with 226 units that have secured entitlements but have not secured building permits, and six projects with 357 units that have secured building permits. These projects total 12 affordable rent-restricted projects with 583 units that will be placed in service within the next 2-3 years (City of Oroville, October 27, 2021).

## RENTAL MARKET

---

Rental market surveys that track average asking rents and vacancy rates are not available for the City of Oroville. However, HUD establishes a Fair Market Rent by unit size annually in order to set contract rents for their subsidy programs. The Fair Market Rents for Butte County by unit size over the past seven years are shown in “Figure 26: Fair Market Rent, Butte County, 2015-2021.” The average Fair Market Rent increased by \$367 over this period, from \$968 in 2015 to \$1,335 in 2021. This was a 38% increase over that seven-year period. The largest annual increase was after the Camp Fire, between 2018 and 2019, when the average Fair Market Rent increased by \$160. Fair Market Rent declined slightly from 2019 to 2020 most likely due to COVID-19 rent freezes, and then increased again in 2021 to levels higher than in 2019.

**Figure 26: Fair Market Rent, Butte County, 2015-2021**

	Studio	1 Bedroom	2 Bedroom	3 Bedroom	4 Bedroom	Average
<b>2015</b>	\$527	\$660	\$870	\$1,242	\$1,541	\$968
<b>2016</b>	\$622	\$713	\$907	\$1,318	\$1,584	\$1,029
<b>2017</b>	\$656	\$729	\$923	\$1,344	\$1,614	\$1,053
<b>2018</b>	\$712	\$785	\$992	\$1,443	\$1,689	\$1,124
<b>2019</b>	\$808	\$894	\$1,144	\$1,654	\$1,921	\$1,284
<b>2020</b>	\$761	\$842	\$1,090	\$1,567	\$1,881	\$1,228
<b>2021</b>	\$825	\$904	\$1,192	\$1,692	\$2,064	\$1,335

*Source: U.S. Department of Housing and Urban Development, Fair Market Rents 2015-2021*

Figure 26.1: Fair Market Rent Chart, Butte County, 2015-2021

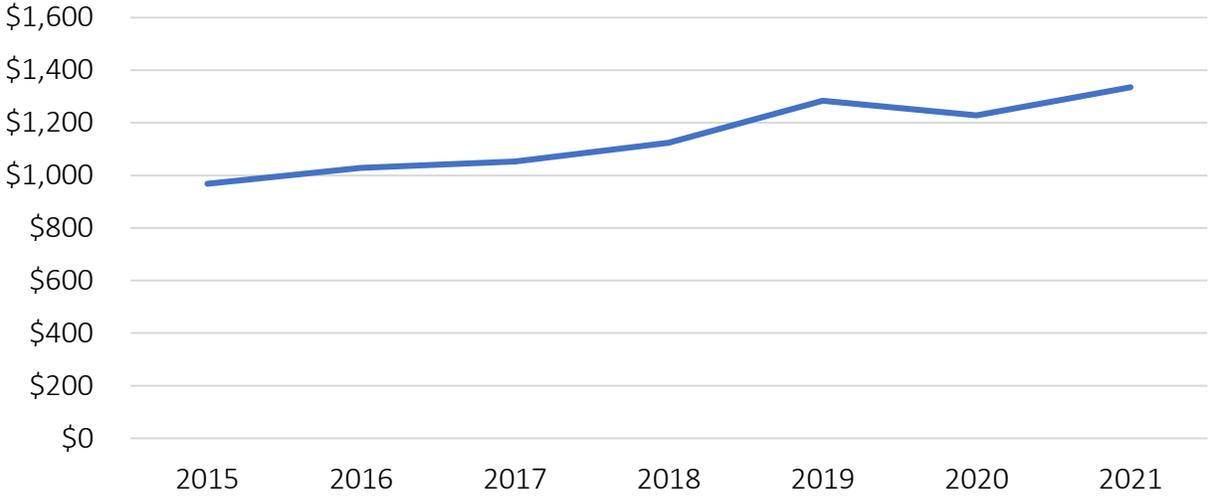

“Figure 26.2: Average Asking Rent by Building Age, City of Oroville, 2020” shows average rents as of 2020. Units built prior to 1970 rent for approximately 67%-75% of new units. Overall average rent was \$1,059.

Figure 26.2: Average Asking Rent by Building Age, City of Oroville, 2020

Year Built	Rent
Before 1970	\$817
1970-1979	\$1,018
1980-1989	\$1,250
1990-1999	\$0
2000-2009	\$1,225
2010+	\$0
All	\$1,059

Source: Kinetic Valuation Group Market Study, 2020

**FOR-SALE MARKET**

The number of homes sold in Oroville has gradually increased from 2014 to 2019, as shown in “Figure 27: Number of Homes Sold by Type, City of Oroville, 2014-2021.” From 2019 to 2021, the number of homes declined again, following population trends over the same period. A significant portion of homes sold have been manufactured homes, at 18.3% of homes sold in 2020.

**Figure 27: Number of Homes Sold by Type, City of Oroville, 2014-2021**

Year	SF	Manufactured	Other	Total
2014	382	104	0	486
2015	432	108	1	541
2016	423	116	2	541
2017	433	110	4	547
2018	497	116	0	613
2019	591	151	0	742
2020	522	118	6	646
2021	408	91	2	501

Source: Sierra North Valley Realtors, September 2021 Multiple Listing Service

**Figure 27.1: Number of Homes Sold Chart, City of Oroville, 2014-2021**

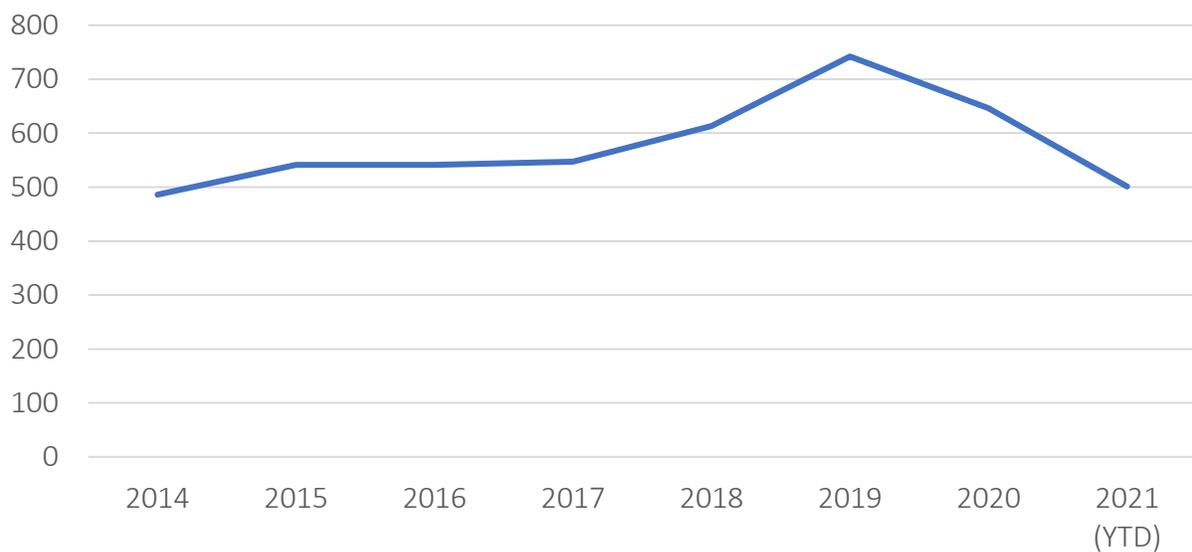

“Figure 27.2: Median Sales Price by Type of Sale, City of Oroville, 2014-2021” shows the median sales price for homes sold in Oroville from 2014 through 2021. The median sales price more than doubled from 2014 to 2021, a dramatic increase of \$165,000 or 114%. The largest increase within that time period was from 2018 to 2019, when the median sales price jumped by \$32,050 or 15%. Median sales prices in nearby Chico rose in a similar fashion at this time, which was the year following the Camp Fire.

**Figure 27.2: Median Sales Price by Type of Sale, City of Oroville, 2014-2021**

Year	SF	Manufactured	Other	Total
2014	\$ 152,450	\$ 110,000	\$ -	\$ 145,000
2015	\$ 164,950	\$ 117,000	\$ 300,000	\$ 150,000
2016	\$ 185,000	\$ 125,000	\$ 195,750	\$ 171,000
2017	\$ 208,000	\$ 139,500	\$ 158,250	\$ 185,600
2018	\$ 218,575	\$ 162,250	\$ -	\$ 209,950
2019	\$ 255,000	\$ 184,837	\$ -	\$ 242,000
2020	\$ 285,220	\$ 195,000	\$ 220,000	\$ 270,000
2021 (YTD)	\$ 325,000	\$ 267,500	\$ 847,500	\$ 310,000

Source: Sierra North Valley Realtors, September 2021 Multiple Listing Service

**Figure 27.2: Median Sales Price by Type of Sale Chart, City of Oroville, 2014-2021**

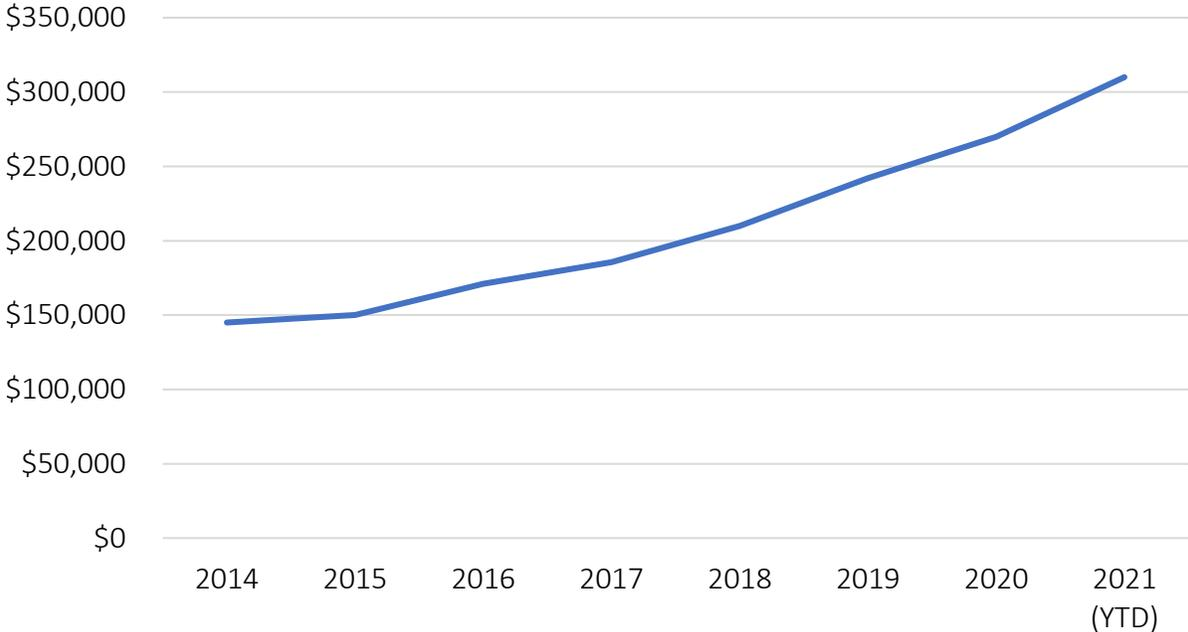

## AT-RISK UNITS

---

Housing Element law (Government Code Section 65583(a)(9)) requires that Housing Elements identify assisted housing developments with contracts restricting rents to affordable levels that will expire within the next 10 years. “Assisted housing developments” include multi-family rental housing that receives government assistance under federal programs, state and local multi-family revenue bond programs, local redevelopment programs, inclusionary housing programs, or local in-lieu fees. There are no housing developments in the City of Oroville that meet these criteria as confirmed by a review of the National Housing Preservation Database and consultation with City of Oroville records.

## HOUSING AFFORDABILITY

---

### *Overpayment*

Housing affordability can be measured by the percent of income paid toward housing costs. HUD considers households that pay over 30% of their income to housing as *rent burdened*.

Households that pay over 50% of their income to housing are considered *severely rent burdened*. This metric indicates the extent of household *overpayment*.

Figure 28 and 28.1 shows a breakdown of payment for housing costs by renter-occupied units. Figure 28 shows payment that is less than or more than 30% of income toward housing costs (rent-burdened households). Figure 28.1 shows payment that is less than or more than 50% of housing costs (severely rent burdened households).

Figure 28 shows that the majority of renter households in Oroville earn less than \$35,000 annually, at 67% of all renter households. An estimated four in five of these households earning less than \$35,000 annually (81%) pay 30% or more of income toward housing costs, or are rent burdened. Figure 28.1 shows that 24% of renter households in Oroville pay 50% or more of income toward housing costs, or are severely rent burdened.

Figure 28: Renters Paying 30% or More of Income Toward Housing Costs, City of Oroville, 2019

Household Income	Less than 30% of Income Toward Housing Cost	30% or More of Income Toward Housing Costs	Total Renter Occupied Housing Units
Less than \$35,000	418	1,790	2,208
\$35,000-49,999	84	223	307
\$50,000-74,999	328	144	472
\$75,000 or more	286	5	291
Zero or Negative Income, No Cash Rent, Not Computed	--	--	222
<b>Total</b>	<b>1,116</b>	<b>2,162</b>	<b>3,483</b>

Source: US Census, 2015-2019 American Community Survey

Figure 28.1: Renters Paying 50% or More of Income Toward Housing Costs, City of Oroville, 2019

Household Income	Less than 50% of Income Toward Housing Cost	50% or More of Income Toward Housing Costs	Total Renter Occupied Housing Units
Less than \$35,000	1,520	817	2,337
\$35,000-49,999	333	0	333
\$50,000-74,999	474	13	487
\$75,000 or more	326	0	326
<b>Total</b>	<b>2,653</b>	<b>830</b>	<b>3,483</b>

Source: US Census, 2015-2019 American Community Survey

Figure 28.2 shows that households in owner-occupied housing units are fairly evenly distributed across the income spectrum, with 30% earning less than \$35,000 annually and 28% earning \$75,000 or more. Of owner households earning less than \$35,000, 62% pay 30% or more of income toward housing costs. Overall, 28% of owners pay 30% or more of income toward housing costs.

Figure 28.2: Owners Paying 30% or More of Income Toward Housing Costs, City of Oroville, 2019

Household Income	Less than 30% of Income Toward Housing Cost	30% or More of Income Toward Housing Costs	Total Owner Occupied Housing Units
Less than \$35,000	341	550	891
\$35,000-49,999	354	158	512
\$50,000-74,999	565	116	681
\$75,000 or more	825	11	836
Zero or Negative Income, No Cash Rent	23	--	23
<b>Total</b>	<b>2,108</b>	<b>835</b>	<b>2,943</b>

Source: US Census, 2015-2019 American Community Survey

“Figure 28.3: Market Rent Compared to Affordable Rent, Butte County, 2021” shows market rent compared to affordable rent by income level. Affordable rent is calculated at 30% of monthly income. A three-person Very Low-Income household earning 50% of Area Median Income can afford rent at \$796, which is \$396 less than the Fair Market Rent for a two-bedroom unit in Butte County. A three-person Extremely Low-Income household earning 30% of Area Median Income can afford rent at \$549, which is \$643 less than the Fair Market Rent for a two-bedroom unit in Butte County.

Figure 28.3: Market Rent Compared to Affordable Rent, Butte County, 2021

Affordability Category	Affordable Rent	Income (3-person Household)	Rent Affordability Gap
<b>Butte County 2-bdrm Fair Market Rent</b>	\$1,192	\$47,680	
<b>Low Income Household</b>	\$1,272	\$50,900	
<b>Very Low Income Household</b>	\$796	\$31,850	\$396
<b>Extremely Low Income Household</b>	\$549	\$21,960	\$643

Source: U.S. Department of Housing and Urban Development, 2021 Fair Market Rent and Section 8 Income Limits

### **Availability of Affordable Units**

“Figure 29: Publicly Subsidized Permanent Rental Units, City of Oroville, 2021” lists publicly subsidized affordable rental units within the City of Oroville. It includes 17 projects with 839 total publicly subsidized permanent rental units, including 63 studios, 248 one-bedrooms, 245 two-bedrooms, 235 three-bedrooms, and 48 four-bedrooms. Seven of the projects are public housing owned by the Housing Authority of the County of Butte. These projects charge rent at 30% of tenant income, regardless of income. The other 10 projects are financed by Low Income Housing Tax Credits (LIHTC), as well as other funding sources. In addition to units listed below, there are an additional 12 projects with a cumulative total of 563 units that are currently in development and will be placed in service within the next three years.

Figure 29: Publicly Subsidized Permanent Rental Units, City of Oroville, 2021

Project Name	Funding Source/ Target Population	1 BR	2 BR	3 BR	4 BR	Total Assisted Units	Average Household Rental Contribution
7 <sup>th</sup> Street	Housing Authority, Family – 80% of Area Median Income			3		3	30% of Income
Boulder Creek	LIHTC - 60% of Area Median Income		88	48	20	156	\$863-\$1,099
Casey Court	Housing Authority, Family – 80% of Area Median Income			8		8	30% of Income
Gardella Street	Housing Authority, Family – 80% of Area Median Income			12		12	30% of Income
Hammon Park	Housing Authority, Family – 80% of Area Median Income			27		27	30% of Income
The Highland Apartments	LIHTC, Family - 60% of Area Median Income	32	54			86	N/A
Hillview Ridge Apartments I	LIHTC, Family and Special Populations - 60% of Area Median Income		23	40	8	71	\$772-\$984
Hillview Ridge Apartments II	LIHTC, Family - 60% of Area Median Income		15	33	8	56	\$356-\$916
Orange Tree Senior Apartments	HUD Multifamily, LIHTC, Senior - 60% of Area Median Income	49				49	\$325
Oro Dam Blvd	Housing Authority, Family – 80% of Area Median Income			17		17	30% of Income

Oroville Apartments	HUD Multifamily, LIHTC - Section 8, 60% of Area Median Income	11	30	20		61	\$282
Oroville Inn	LIHTC, Northwest Lineman College Housing					59	\$580
Oroville Manor	LIHTC, Senior - 60% of Area Median Income	67				71	N/A
Pomono Avenue	Housing Authority, Family – 80% of Area Median Income			3		3	30% of Income
Sierra Heights Senior Apartments	LIHTC, Senior	32	8			40	N/A
Sierra Village	LIHTC, Family - 60% of Area Median Income		24	24	12	60	N/A
Winston Gardens	Housing Authority, Senior/Disabled – 80% of Area Median Income	57	3			60	30% of Income
<b>Total</b>		<b>248</b>	<b>245</b>	<b>235</b>	<b>48</b>	<b>839</b>	

Sources: Cambridge Real Estate Services, 2021; City of Oroville, 2021; Housing Authority of the County of Butte, 2021; Oroville Inn, 2021; PolicyMap, 2021

“Figure 29.1: Low-Income Households Relative to Subsidized Housing Units, City of Oroville, 2021” illustrates the affordable housing gap in Oroville. As of 2019, there were an estimated 3,251 households in Oroville earning less than \$35,000 in the previous 12 months, which is roughly equivalent to a four-person Very Low-Income household in Butte County per the State Income Limits. Of these households, 2,340 pay over 30% of income or more toward housing costs. As shown on Figure 28.3, these households cannot afford the Fair Market Rent. When compared to the number of subsidized housing units in Oroville at 1,404, this leaves a gap of 936 affordable units that are needed to assist households earning less than \$35,000 that are rent-burdened. The number of subsidized housing units includes 839 publicly-subsidized rent-restricted units, 552 households with Section 8 Housing Choice Vouchers that reside in Oroville, and 13 households with HUD VASH vouchers that reside in Oroville.

Figure 29.1: Low-Income Households Relative to Subsidized Housing Units, City of Oroville, 2021

	Number of Households
Earning < \$35,000	3,251
Paying > 30% of Income to Housing Costs	2,340
Paying > 50% of Income to Housing Costs	817
Subsidized Housing Units	1,404
Unmet Need	936

Source: Housing Authority of the County of Butte, 2021; U.S. Census Bureau, 2015-2019 American Community Survey

Figure 29.2: Low-Income Households Relative to Subsidized Housing Units Chart, City of Oroville, 2021

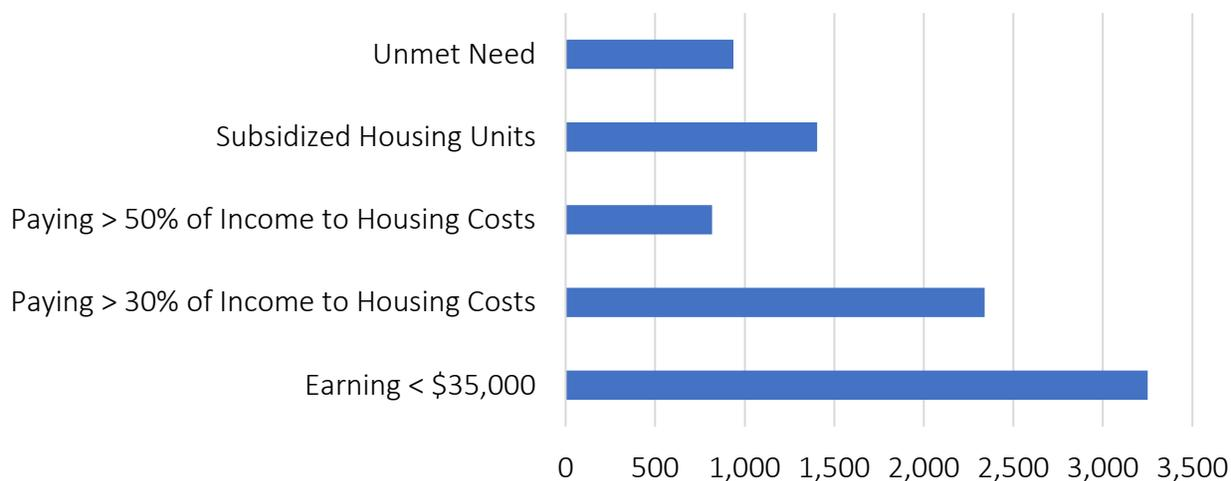

**For-sale Home Affordability**

“Figure 30: For-Sale Home Affordability, City of Oroville, 2021” breaks down the median income affordable home price compared to the price of a typical new starter home, the median home price, and the typical mid-range new home price. The median home price is about 17% lower than the price affordable to a Butte County four-person median income household. The estimated price of a mid-range new home is about 5% higher than the price affordable to a four-person median income household.

**Figure 30: For-Sale Home Affordability, City of Oroville, 2021**

	Median Income Affordable Home Price	Typical New Starter Home Price (1,200 sq. ft.)	Median Home Price	Starting Mid-Range New Home Price (2,000 sq. ft.)
<b>Household Income</b>	\$70,700	\$45,397	\$59,172	\$75,434
<b>Affordable Monthly Housing Payment</b>	\$2,062	\$1,324	\$726	\$2,200
<b>Subtract Taxes, MI, and Property Insurance</b>	\$496	\$347	\$444	\$571
<b>Mortgage Payment</b>	\$1,547	\$977	\$1,282	\$1,629
<b>Affordable Mortgage</b>	\$355,363	\$224,580	\$294,500	\$374,300
<b>Down Payment</b>	\$18,703	\$11,820	\$15,500	\$19,700
<b>Affordable Home Price</b>	\$374,066	\$236,400	\$310,000	\$394,000

Assumes affordable housing payment at 35% of monthly income, 3.25% interest rate, 30-year fixed-rate mortgage, 5% down payment, property taxes at 1.1%, monthly mortgage insurance payments of \$80-\$130, monthly property insurance payments of \$50-\$80. Median home price based on the 2020 median sales price.

Source: Sierra North Valley Realtors, December 2020 Multiple Listing Service, California Department of Housing and Community Development, April 2020

## EXTREMELY LOW-INCOME HOUSEHOLDS

### *Income*

Extremely Low-Income (ELI) households earn less than 30% of the Area Median Income, as defined by federal and state governments. In Butte County, 30% of Area Median Income ranges from \$14,850 for a one-person household to \$31,040 for a five-person household. As of 2019, the U.S. Census estimated that there were 2,071 households in Oroville earning less than \$25,000 annually, which is 32% of all households, as shown in “*Figure 24.1: Household Income, City of Oroville, 2019.*”

The Federal Poverty Level is a measure of material need used by federal agencies to determine eligibility for certain programs and benefits. For 2021, the Federal Poverty Level ranged from \$12,880 for a one-person household to \$31,040 for a five-person household, which nearly aligns with ELI incomes for Butte County. In 2019, there were an estimated 708 families with income below the Poverty Level in Oroville (18.1% of all families in Oroville). (*Figure 31: Families Living Below the Poverty Level, City of Oroville, 2019*)

**Figure 31: Families Living Below the Poverty Level, City of Oroville, 2019**

	Number of Households	% of Total
Income below poverty	708	18.1%
Income below poverty, nonfamily, female householder	352	9.0%
Income below poverty married-couple family	325	8.3%
<b>Total Households</b>	3,917	--

Source: U.S. Census Bureau, 2015-2019 American Community Survey

### *Overpayment*

Most ELI households are rent burdened, many live in overcrowded conditions, and many are at-risk of becoming homeless. “*Figure 28: Renters Paying 30% or More of Income Paid Toward Housing Costs, City of Oroville, 2019*” shows that there were 1,790 renter households in Oroville that earned less than \$35,000 annually as of 2019 (18% of all households). Of these households, 81% paid 30% or more of their income toward housing costs, and 35% paid 50% or more of their

income toward housing costs, as shown in “*Figure 28.1: Renters Paying 50% or More of Income Paid Toward Housing Costs, City of Oroville, 2019.*”

### ***Overcrowding***

Given the limited purchasing power of ELI households, and the large proportion of ELI households that are rent burdened, it is likely that a large proportion of Overcrowded households are ELI. “*Figure 25.3: Tenure by Occupants per Room, City of Oroville, 2019*” shows that in 2019, there were an estimated 442 Overcrowded and 113 Severely Overcrowded housing units in Oroville.

### ***Available Units, Resources, and Policies***

The Regional Housing Needs Allocation for Oroville estimates a need for the production of 171 units affordable to Very Low-Income households, half of which should be affordable to ELI households, over the 2022-2030 Housing Element planning period. The provision of ELI affordable housing usually requires significant public subsidy for capital costs as well as operations. The very low ELI affordable rents usually necessitate rental assistance such as Section 8 Project Based Vouchers to cover operating expenses. This type of rental assistance pays the landlord the difference between 30% of tenant income and Fair Market Rents as set by HUD. In addition to financing, various local policies can help facilitate the production of ELI housing. These are listed below:

- Allowance for Single-Room Occupancy (SRO), group homes, and/or tiny home projects as permitted uses in the zoning code; and
- Allowance for Transitional and Supportive Housing in all residentially zoned districts, with no restrictions beyond what would apply to any other types of residential development. Revisions to the Municipal Code to achieve this policy are laid out in the Chapter 3 Housing Program, Programs 2.1.6 and 2.1.7.

## **SPECIAL NEEDS HOUSEHOLDS**

---

### ***Seniors***

As of 2019, there were an estimated 4,167 people 60 years and older in Oroville. This is approximately 21% of the population. Of householders in Oroville that are 65 years and older, half (864 households) have an annual income that is less than \$30,000. An estimated 69% have

income less than 45,000. This points to the need for affordable housing for seniors. Most seniors have fixed incomes because they are no longer employed. Seniors with limited fixed incomes require restricted affordable rents that provide predictability, security, and stability. (Figure 32: *Income for Householders 65 Years and Over, City of Oroville, 2019*)

Figure 32: Income for Householders 65 Years and Over, City of Oroville, 2019

	Number of Households	% of All Senior Householders
Less than \$15,000	289	16.7%
\$15,000 to \$29,999	575	33.3%
\$30,000 to \$44,999	321	18.6%
\$45,000 to \$59,999	269	15.6%
\$60,000 to 74,999	78	4.5%
\$75,000 to \$99,999	105	6.1%
Over \$100,000	89	5.2%
<b>Total</b>	<b>1,726</b>	<b>--</b>

Source: U.S. Census Bureau, 2015-2019 American Community Survey

As shown in “Figure 32.1: Persons with a Disability by Age, City of Oroville, 2019,” an estimated 1,236 persons 65 years and older in Oroville have a disability. This is 32% of the estimated 3,904 persons with a disability in Oroville, and 43% of the 2,888 persons in this age group. This is higher than the proportion of persons 65 years and older with a disability for the State of California as a whole (35%).

Figure 32.1: Persons with a Disability by Age, City of Oroville, 2019

	Persons with a Disability	% of Total Population
<b>Total population w/ a disability</b>	3,904	21.9%
<b>Under 18 years</b>	246	1.4%
<b>Age 18 to 64</b>	2,422	13.6%
<b>65 years and over</b>	1,236	6.9%
<b>Total Civilian Non-institutionalized Population</b>	17,825	--

Source: U.S. Census Bureau, 2015-2019 American Community Survey

Seniors benefit from a continuum of housing options that accounts for mental and physical disabilities, and restricted mobility challenges that may change over time. Publicly subsidized affordable housing typically helps seniors live independently and age in place for as long as possible. The physical design incorporates ADA units and ADA adaptable features for physical and sensory impairments, in addition to full accessibility to units and common areas for wheelchair users. Semi-independent retirement communities and nursing facilities are other residential models that meet critical needs for seniors. There are currently eight state-licensed assisted living care facilities for the elderly with a cumulative capacity for 339 persons in Oroville (State of California Community Care Licensing Division, 2021). In addition, there are three senior low-income affordable rental properties in Oroville as listed below with a cumulative 160 units.

- Orange Tree Senior Apartments— 49 units (all one-bedroom)
- Oroville Manor—71 units (4 studios and 67 one-bedrooms)
- Sierra Heights Senior Apartments— 40 units (32 one-bedrooms and 8 two-bedrooms)

There are also three additional senior low-income affordable rental properties that are in development and expect to be placed in service within the next three years, as listed below:

- Olive Ranch Apartments, Phase 3— 51 units
- AMG Mitchell Avenue— 72 units
- Sierra Heights Apartments, Phase 2— 48 units

### *Persons with a Disability*

Persons with disabilities have particular housing needs depending on their situation. Public funding sources for housing typically require that 5%-10% of units are fully accessible for persons with physical disabilities per the American with Disabilities Act, and that 2% are accessible to persons with sensory disabilities. In addition, publicly assisted affordable housing often offers resident services that connect tenants with local peer support and advocacy organizations, health services, and transportation assistance. A number of federal and state sources fund Permanent Supportive Housing for persons with mental disabilities, which include individualized case management and mental health services.

There were an estimated 3,904 persons with a disability in Oroville in 2019 according to the U.S. Census. This was 22% of the total civilian non-institutionalized population in Oroville. This was much higher than the proportion of persons with a disability statewide, which was about 11%. “Figure 33: Disability Characteristics, City of Oroville, 2019” shows persons with a disability by type of disability. One individual may have more than one type of disability. The most commonly identified type of disability listed is “cognitive difficulty”, followed closely by “ambulatory difficulty”.

**Figure 33: Disability Characteristics, City of Oroville, 2019**

	Persons
Total civilian non-institutionalized population	17,825
Persons with a disability	3,904
Hearing difficulty	788
Vision difficulty	639
Cognitive difficulty	2,097
Ambulatory difficulty	1,963
Self-care difficulty	1,060
Independent living difficulty	1,801

Source: U.S. Census Bureau, 2015-2019 American Community Survey (civilian noninstitutionalized population)

State Housing Element law also requires jurisdictions to specifically analyze needs for persons with developmental disabilities. The California State Department of Developmental Services provides data on Regional Center and Early Start consumers by zip code. The City of Oroville includes zip codes 95965 (which also includes Butte Valley, Pulga, and Yankee Hill) and 95966. In the 95965 zip code, there were 420 consumers (168 consumers under 18 years old and 252 consumers 18 years old or older) with developmental disabilities as of the end of September, 2021. The residency of these consumers included: 266 living at home of parent/family/guardian; 95 in independent/supported living; 46 in a community care facility; 7 in a foster/family home; and 6 others. In the 95966 zip code, there were 490 consumers (212 under 18 years old and 278 over 18 years old) with developmental disabilities as of the end of September 2021. The residency of these consumers included: 343 living at home of parent/family/guardian; 113 in independent/supported living; 20 in a community care facility; 7 in a foster/family home; and 7 others.

The Far Northern Regional Center manages services for persons with developmental disabilities in Butte County. The Far Northern Regional Center provides early intervention and behavior services, respite care, licensed homes, adult day activities, supported employment, and healthcare coordination. There are two low-income, publicly subsidized housing complexes with units targeted to persons with disabilities in Oroville.

The City of Oroville does have a reasonable accommodation policy for persons with disabilities to request zoning and building code variances. Reasonable accommodation requests can be approved at a staff level either the Zoning Administrator or their designee.

***Female-Headed Households***

Almost over one in three families in Oroville (31%) are female-headed households with no spouse present, which is an estimated 1,217 families. These families have a much lower median income than married-couple families, and families in general, as shown in “*Figure 34: Family Median Income, City of Oroville, 2019.*” The median income for female-headed families is 62% of the median income for married-couple families.

**Figure 34: Family Median Income, City of Oroville, 2019**

	Median Income
Families	\$48,664
Married-couple families	\$56,973
Female householder, no spouse present	\$30,306
Male householder, no spouse present	\$44,567
Households (All)	\$34,428

Source: U.S. Census Bureau, 2015-2019 American Community Survey

Another indicator of economic well-being is the number of families with income below the poverty level. A larger proportion of female-headed families in Oroville has income below the poverty level (28.9%) than families overall (18.1%). For female householders with related children under 18 years old, the percentage of families below the poverty level is much higher, at 56.1%. *(Figure 34.1: Female Householder Families Below Poverty Level, City of Oroville, 2019)*

Figure 34.1: Female Householder Families Below Poverty Level, City of Oroville, 2019

	Number of Female Householder Families, No Spouse Present	% of Female Householder Families, No Spouse Present	Number of Female Householder Families, No Spouse Present, With Related Children of the Householder Under 18 Years	% of Female Householder Families, No Spouse Present, With Related Children of the Householder Under 18 Years
<b>Below poverty level</b>	352	28.9%	303	56.1%
<b>At or above poverty level</b>	865	71.1%	237	43.9%
<b>Total</b>	1,217		540	

Source: U.S. Census Bureau, 2015-2019 American Community Survey

Female-headed households can benefit from a number of features offered by publicly subsidized housing. Most importantly this type of housing offers affordable restricted rent. In addition, many of these types of housing projects offer after-school programs and youth recreation programs. Many also have amenities such as computer labs, community rooms for youth activities and adult education, and playgrounds. Affordable childcare is also a critical need for these families.

**Large Households**

“Figure 37: Household Size, City of Oroville, 2019” depicts the size and tenure of all households in Oroville. Nearly 60% of all households have two or fewer persons. Most owner households are two-person households and most renter households are one-person households. Households with three or more persons are more likely to be renter households than owner households. An estimated 11.8% of all households have five persons or more, which is an estimated 763 households. Of these large households, 58.8% are renters.

Figure 37: Household Size, City of Oroville, 2019

	All Households	% of Total	Owner Households	Renter Households
1-person	1,938	30.2%	851	1,087
2-person	1,858	28.9%	1,066	792
3-person	1,120	17.4%	406	714
4-person	747	11.6%	306	441
5-person	426	6.6%	197	229
6-person	225	3.5%	83	142
7-or-more-person	112	1.7%	34	78

Source: U.S. Census Bureau, 2015-2019 American Community Survey

“Figure 35.1: Median Family Income by Family Size, City of Oroville, 2019” shows that families with six or more persons have slightly higher median income than families with fewer persons. Insufficient data is available to calculate median family income for families with five persons.

Figure 35.1: Median Family Income by Family Size, City of Oroville, 2019

	Median Income
2-persons	\$48,558
3-persons	\$33,309
4-persons	\$49,299
5-persons	--
6-persons or more	\$54,575

Source: U.S. Census Bureau, 2015-2019 American Community Survey

Due to expensive housing costs and other costs of living, many large households earning near or less than median income may struggle to make ends meet. Large households also face challenges securing housing that is not overcrowded. The 2021 Fair Market Rent for a four-bedroom unit in Butte County is \$2,064, which would be affordable for a household earning at least \$82,560 annually, which is much higher than the Oroville median income for families with six persons or more. This rent is also unaffordable for four-person families earning 80% of Area Median Income at \$63,350.

Publicly subsidized housing with three-bedroom or four-bedroom units addresses the needs of Low-Income large families. In Oroville, there are 11 affordable rental complexes with a cumulative total of 235 three-bedroom apartments. In addition, four of these affordable rental complexes have a cumulative total of 48 four-bedroom apartments.

### ***People Experiencing Homelessness***

The Butte Countywide Homeless Continuum of Care conducts a Point-In-Time Homeless Census every other year. People experiencing homelessness complete voluntary surveys that provide information about the characteristics and causes of homelessness. This is not an exhaustive survey of every individual experiencing homelessness throughout the year, but a snapshot of the number of individuals surveyed on one particular day of the year. The actual number of persons experiencing homelessness at any point during the year is likely higher than the number surveyed in the Point-In-Time Homeless Census.

The most recent Point-In-Time Census for Butte County was conducted in January of 2019. The 2021 Point-In-Time Census was rescheduled to January of 2022 due to the COVID-19 pandemic. The 2019 Point-In-Time Census counted 415 individuals experiencing homelessness in Oroville. Below are noteworthy data points.

- One quarter of these individuals were “chronically homeless”, which means that they had a disability and lived in a shelter, safe haven, or place not meant for human habitation for 12 continuous months or for four separate occasions in the last three years.
- In terms of nighttime habitation, 37% were sleeping on the street or sidewalk, 24% were sleeping at an outdoor encampment, and 13% were staying with a friend or family member.
- Of the 415 individuals surveyed, 85% lived in Butte County when they lost their housing, and 47% reported this was their first time they have experienced homelessness.
- The 2018 Camp Fire had been a significant factor in causing homelessness in Oroville, as 15% of the individuals surveyed reported being survivors of the Camp Fire and had lived in Camp Fire affected areas.

Beyond permanently affordable rental housing, there are a variety of sheltering strategies that have been implemented across the country to assist persons experiencing homelessness. Emergency shelters provide short term shelter, often with referral to other longer-term housing options as well as community services. Transitional housing provides temporary housing, usually for periods of up to 24 months at a time, with supportive services that assists residents to build self-sufficiency and transition to permanent housing. Permanent Supportive Housing is housing without a limit on the length of residency that provides a variety of supportive services to help residents stabilize and progress in terms of health, income, and/or employment. The Oroville Rescue Mission is a nonprofit organization that runs two emergency shelters in Oroville— Timothy Housing, which is a men’s shelter with 24 beds; and Bethel House, a Women and Children’s shelter with 14 beds. The Oroville Rescue Mission also provides clothing and food distribution, and drug and alcohol support services. The City also made progress in the development of Permanent Supportive Housing as follows:

- Base Camp Village is a 12-unit permanent supportive housing project for people experiencing homelessness with a mental illness diagnosis. The housing project opened in April 2020.
- Prospect View will be another newly constructed project which will offer 39 units of permanent supportive housing for people experiencing homelessness with a mental illness. Construction is slated to begin in 2022 with units available for occupancy in 2023.

## Farmworkers

An estimated 94 people were employed in the Agriculture, Forestry, Fishing and Hunting, and Mining Industry in Oroville as of 2019, which was 1.5% of all employed residents. There is a higher proportion of people employed in these industries in Butte County as a whole, and the State of California. (*Figure 36: Agriculture and Related Occupations, City of Oroville, 2019*)

Figure 36: Agriculture and Related Occupations, City of Oroville, 2019

	Number of People Employed in Agriculture, Forestry, Fishing and Hunting, and Mining Industry	% of Total Employed Population
City of Oroville	94	1.5%
Butte County	3,874	4.0%
State of California	415,545	2.2%

Source: U.S. Census Bureau, 2015-2019 American Community Survey

The Census of Agriculture is conducted every five years by the U.S. Department of Agriculture (USDA), and is a count of U.S. farms and ranches and the people who operate them. This data is available at the county level but not the city level and is provided for additional context about farmworkers in Butte County. About 13% of all workers on farms with hired labor in Butte County are migrant workers. This means these workers travel from their permanent place of residence to find work at one or more agricultural employers. (Figure 36.1: Farm and Labor Characteristics, Butte County, 2017)

Figure 36.1: Farm and Labor Characteristics, Butte County, 2017

Jurisdiction	Number of Farms	Number of Farms with Hired Labor	Number of Workers on Farms with Hired Labor	Total Migrant Workers on Farms with Hired Labor
Butte County	1,912	709	4,348	580

Source: U.S. Department of Agriculture, 2017 Census of Agriculture

The Housing Authority of the County of Butte (HACB) owns farm labor housing (also known as farmworker housing) in the City of Gridley which is located in south Butte county. The farmworker housing in Gridley is located approximately 30 miles from Chico via Highway 99. This is the only farmworker housing owned by HACB in Butte County.

HACB and property management firm AWI Management Corporation staff provided information about the Gridley farmworker housing via email correspondence on April 7 and April 19, 2022.

There are 79 occupied units with an average rental contribution of \$524 per month. There are 4 one-bedroom units, 59 two-bedroom units, 12 three-bedroom units, and 4 four-bedrooms units. At the time of the correspondence, there were eight households on the waiting list for a unit. AWI Management Corporation had started marketing for units using local radio, printing leasing banners, and generating flyers for distributing to local agricultural employees.

Community Housing Improvement Program (CHIP) is a private, non-profit 501(c)(3) corporation serving Butte, Glenn, Tehama, Shasta, Sutter, Yuba, and Colusa counties. CHIP assists low-income and rural disadvantaged residents, seniors, and others who lack financial resources or knowledge to improve or provide adequately for their housing. CHIP has built more than 2,600 housing units in its seven-county service area (*Community Housing Improvement Program, Website, 2022*).

In an interview for the Housing Element on April 11, 2022 via Zoom and email correspondence on April 4 and 22, 2022, CHIP staff shared farmworker housing needs and resources in Butte and Glenn counties where their properties are located. CHIP has three farmworker housing projects, with the first coming online in the 1980s. La Vista Verde in Chico (Butte County) has 33 units, Las Palmas in Hamilton City (Glenn County) has 12 units, and Rancho de Soto in Orland (Glenn County) has 33 units. All three properties have U.S. Department of Agriculture (USDA) funding, and Rancho de Soto also has Joe Serna, Jr. Farmworker Housing Grant Program and Low-Income Housing Tax Credits (LIHTC) funding.

La Vista Verde in Chico has 14 two-bedroom, 14 three bedroom, and 4 four-bedroom units in addition to 1 four-bedroom manager's unit. The average tenant rental contribution per month is \$423. The waitlist is minimal with two households as of April 11, 2022. Staff commented this is due to difficulty with qualifying households and filling units, which is explained in more detail in the following paragraphs.

CHIP's farmworker housing tenants typically work locally in fields, orchards, dairies, factories, and warehouses that process agricultural products. Some of the tenants work seasonally and others work year-round. Some seasonal workers have different employment in different seasons. Workers are busiest during harvest May through June and September through October. According to property management staff, tenants' employment was not affected much by the COVID-19 pandemic.

All three farmworker housing projects in Butte and Glenn counties require eligible immigration status (e.g. permanent resident, citizen, etc.), and a low-income of 50% AMI or less. If one member of the household is working full-time at the California minimum wage of \$15 per hour, any overtime puts the household over the income requirement. Overtime is common for farmworkers at certain times of the year due to seasonal crop harvest. Thus, to meet income requirements with one person of the household working full-time with some overtime, a household would need to be at least three-persons and some households would need to be at least four-persons to qualify. Staff observed that workers with eligible immigration status tend to earn more than what the income limits allow for the housing projects. Rancho de Soto in Orland has LIHTC funding which requires between 30-50% AMI, which staff commented makes it more

challenging to find qualified households. Staff shared their perspective that Area Median Income (AMI) is too low for Butte county. Farmworkers with eligible immigration status are typically paid at least minimum wage. With a two-income household, this means they are not eligible for CHIP's housing because they are over income at higher than 50% AMI.

CHIP staff shared unmet needs of farmworker housing in Butte and Glenn counties. These unmet needs include housing that does not require eligible immigration status. There is a mismatch of income and status occurring. Farmworkers with eligible status have higher incomes and do not qualify for housing, whereas farmworkers without documentation have lower incomes but do not qualify for housing due to lack of eligible status. The typical reason for denying an applicant is due to a lack of eligible immigration status. While CHIP staff has had periodic conversations with USDA about these regulations they do not know of organized statewide advocacy on this issue. Though temporary waivers for projects are possible from USDA, USDA and HCD would have to work together to address regulation issues because both funding sources are typically part of farmworker housing projects.

After the 2018 Camp Fire, USDA temporarily waived the farmworker requirement for farmworker housing. Camp Fire survivors who were not farmworkers were able to move into La Vista Verde in Chico and Las Palmas in Hamilton City. This did not happen at Rancho de Soto in Orland due to LIHTC requirements. CHIP's property management staff stated that at one point after the Camp Fire, La Vista Verde had almost one-third of units filled by fire survivors who were not farmworkers. Effects of this atypical dynamic included more pets and service animals and some tension between long-term farmworker tenants and the new Camp Fire survivor tenants, the latter of which was not strongly welcomed into the community by the former. Long-term farmworker tenants cited issues of fairness, wondering why the new tenants did not have to be farmworkers to qualify for the housing while they did.

In conclusion, there are four farmworker housing projects in Butte and Glenn counties owned by HACB and CHIP. While these counties are known as agriculturally rich areas, issues persist with matching housing needs to available resources for farmworker households. A mismatch of need to regulated resources is occurring, causing resources to be underutilized and households not being able to be housed.

## CHAPTER 5: RESOURCE INVENTORY

This chapter will describe the various resources that can be employed to produce a variety of housing types to meet the needs described in Chapter 4. The principal resources required are adequate appropriately zoned land and financing. There are opportunities to use these resources to not only produce housing, but also further energy conservation, as residential structures are a major energy user and greenhouse gas producer. This chapter will explore available resources in the following sections:

- Adequate Sites Inventory
- Financial Resources
- Energy Conservation Opportunities

### ADEQUATE SITES INVENTORY

---

#### *Regional Housing Needs Allocation*

State Housing Element Law requires local governments to plan for their housing needs based on future growth projections that established by the Regional Housing Needs Allocation (RHNA). The RHNA establishes goals for the production of housing affordable to various income levels—Above Moderate-, Moderate-, Low-, and Very Low-Income. The goals for Extremely Low-Income and Very Low-Income affordable units are even (50/50) split of the Very Low-Income goal as shown below (85.5 Extremely Low- and 85.5 Very Low-Income). The goals are generally set every 7.5 years and correspond with Housing Element planning periods. “*Figure 37: Regional Housing Needs Allocation, City of Oroville, 2022-2030*” lists the RHNA goals by income level for the 2022-2030 planning period (January 1, 2022 through June 30, 2030).

Figure 37: Regional Housing Needs Allocation, City of Oroville, 2022-2030

Affordability Tier	Number of Units Allocated	Percentage
Very Low	171	27.4%
Low	6	1.0%
Moderate	73	11.7%
Above Moderate	375	60.0%
Total	625	100%

Source: Butte County Association of Governments, 2020 6<sup>th</sup> Cycle Regional Housing Needs Plan

**Analysis of Density to Accommodate Lower Income Housing**

Government Code Section 65583.2 requires each community to ensure that there is adequate appropriately zoned land within its jurisdiction to accommodate its RHNA. This process is implemented through the Adequate Sites Inventory, which identifies sites that are appropriately zoned and can feasibly developed within the Housing Element planning period. The local jurisdiction’s allowable density as laid out in its zoning code is used to determine the RHNA income level that will apply to each site identified in the Adequate Sites Inventory. State Housing Element Law recognizes that higher densities generally facilitate greater affordability in housing. Government Code Section 65583.2©(3) requires that Housing Elements establish a reasonable baseline density to feasibly develop Lower Income housing for the Low- and Very Low-Income RHNA income levels for the Adequate Sites Inventory. For this purpose, the development density of six developments that have recently secured entitlements and tax credit allocations in 2020 in Oroville have been analyzed. The baseline density has been established by averaging the density of these Oroville projects that are listed in “Figure 37.1: Low Income Density Analysis.” Sierra Heights Phase II and Riverbend Family Apartments are on MXC-zoned parcels that are being developed densities lower than the average density of the six affordable developments . Sierra Heights Phase II is being developed at the lowest density due to a steep slope on the site. However, the City has recently received proposals for multi-family housing in MXC zones at much higher densities. Cascade Apartments has submitted a proposal for planning permit that is 42 units on 1.55 acres for 27.1 units per acre. Lincoln Affordable Apartments has submitted a proposal for planning permit that is 408 units on 13.56 acres for 30 units per acre. As demonstrated, recent multi-family proposals in the R-3 zone are trending toward higher densities. The average density of the projects listed in Figure 37.1 is 18.27 units per acre. Therefore, any site identified to meet the Lower Income RHNA in the Adequate Sites Analysis must allow residential uses by right or have secured entitlements, and be in a zoning district that allows at least 18 units per acre.

Figure 37.1: Low Income Density Analysis

Project Name	Zoning	Allowable Density (du/ac)	Units	Acres	Units/Acre
Sierra Heights Phase II	MXC	10-30	48	3.76	12.77
Oroville Heights Apartments	R-3	14-20	66	4.96	13.31
Olive Ranch Phase I	R-4	20-30	81	3.15	25.71
Olive Ranch Phase II	R-4	20-30	80	2.74	29.20
Mitchell Avenue Senior Apts.	R-3	20-30	36	1.99	18.09
Riverbend Family Apartments	R-3	20-30	72	4.36	16.51
<b>Average</b>			64	3.49	18.27

Source: City of Oroville, 2021

### *Analysis of Realistic Capacity*

Government Code Section 65583.2© (1&2) requires that the Housing Element establish a realistic capacity for each parcel listed in the Adequate Sites Inventory. For this purpose, Figure 37.1 lists the multifamily densities for six low-income affordable projects that were recently entitled and secured tax credit allocations in 2020, as described above. The average density of these projects is 18.27 units per acre. The City of Oroville zoning code permits residential uses with densities of 18 units per acre by right in the R-3 and MXC zoning districts. The minimum density in the R-4 zoning district is 20 units per acre. In certain circumstances developers may apply an affordable housing density bonus that allows much greater densities. Therefore, 18 units per acre is a reasonable conservative assumption of capacity for sites identified as Lower Income in the Adequate Sites Inventory.

### *Sites Inventory*

The sites listed in “Figure 37.2: Adequate Sites Inventory, Low and Very Low Income” are currently vacant and zoned for residential uses at densities that will allow for development that meets the RHNA for Low- and Very Low-Income levels. Three of the sites have Mixed Use

General Plan Designations and MXC Zoning that allows 10-30 dwelling units per acre. The other site has a High Density Residential General Plan Land Use Designation and R-3 Zoning that allows 20-30 dwelling units per acre. The capacity for the Mixed Use sites listed are projected at 18 units per acre, which is within the allowable density range for MXC zoning. The Capacity for the Medium High Density Residential site is 20 units per acre, which is within the allowable density range for R-3 zoning. All of the sites are vacant and none of them have development constraints. The location of all Low- and Very Low-Income housing sites are also shown on the “Figure 38: Lower-Income Sites Inventory Map” under the AFFH: Site Inventory section of this chapter.

**Figure 37.2: Adequate Sites Inventory, Low and Very Low Income**

Map ID	APN	General Plan	Zoning	Acres	Developable Acres	Units Per Acre	Projected Units
1	035-250-054	MU	MXC	2.72	2.72	18	48
2	035-250-002	MHDR	R-3	3.91	3.91	18	70
3	035-240-100	MU	MXC	1.55	1.55	18	27
4	035-040-056	MU	MXC	6.50	6.50	18	117
<b>Total</b>				14.73	14.73	18	262

Source: City of Oroville, 2021

“Figure 37.3: Adequate Sites Inventory, Moderate-Income” lists two sites that will meet the RHNA for Moderate-Incomes. The sites are vacant and infill. The sites have a Medium Density Residential General Plan Land Use Designation and R-2 Zoning that allows 6-14 dwelling units per acre. The capacity for the site listed is projected at 6 units per acre, which is the minimum density for the R-2 zoning district. All of the sites are vacant and none of them have development constraints. The location of all Moderate-Income housing sites is also shown on the “Figure 38.1: Moderate-Income Sites Inventory Map” under the AFFH: Site Inventory section of this chapter.

Figure 37.3: Adequate Sites Inventory, Moderate-Income

Map ID	APN	General Plan	Zoning	Acres	Developable Acres	Units Per Acre	Projected Units
1	031-100-008	MDR	R-2	9.50	9.50	6	57
2	031-100-001	MDR	R-2	3.49	3.49	6	20
<b>Total</b>				12.99	12.99	6	77

Source: City of Oroville, 2021

“Figure 37.4: Adequate Sites Inventory, Above Moderate-Income” lists three sites that will meet the RHNA for Above Moderate-Incomes. The sites are vacant and infill. Two of the sites have a Rural Residential General Plan Land Use Designation and RR-20 Zoning that allows one unit per lot with a minimum lot size of 20,000 square feet, allowing about two units per acre. The capacity for the site listed is projected at 3 units per acre, which is the maximum density for the land use designation and similar to the density of recent subdivisions in this zoning district. One of the sites has a Medium Low Density General Plan Land Use Designation and R-1 Zoning that allows 3-6 dwelling units per acre. Based on the tentative subdivision map for this site, there will be 338 lots, calculating to a density of 6 units per acre. All of the sites are vacant and none of them have development constraints. The location of all Above Moderate-Income housing sites are also shown on the “Figure 38.2: Above Moderate-Income Sites Inventory Map” under the AFFH: Site Inventory section of this chapter.

Figure 37.4: Adequate Sites Inventory, Above Moderate-Income

Map ID	APN	General Plan	Zoning	Acres	Developable Acres	Units Per Acre	Projected Units
1	031-100-024	RR	RR-20	8.87	8.87	3	26
2	031-100-025	RR	RR-20	8.85	8.85	3	26
3	031-020-043	MLDR	R-1	56.45	56.45	6	338
<b>Total</b>				74.17	74.17	5.26	390

Source: City of Oroville, 2021

“Figure 37.5: RHNA and Sites Inventory” shows the 2022-2030 RHNA and Adequate Sites Inventory total units by income level. This shows that there are more than enough units identified in the sites inventory to meet the RHNA goals. The City has not received any requests to develop housing below the identified densities in the Sites Inventory.

**Figure 37.5: RHNA and Sites Inventory**

Income Level	RHNA	Sites Inventory	Surplus (Deficit)
Lower Income (Very Low and Low Income)	177	262	85
Moderate Income	73	77	4
Above Moderate Income	375	390	15
<b>Total</b>	<b>625</b>	<b>729</b>	<b>104</b>

Source: Butte County Association of Governments, 2020 6<sup>th</sup> Cycle Regional Housing Needs Plan

***Environmental Constraints to Housing Development***

Oroville is located in southeast Butte County, 20 miles southeast of Chico, 30 miles east of the Sacramento River. It is bordered on the north by Lake Oroville, and on the west by the Thermalito Afterbay, which is connected to Lake Oroville. The Feather River flows southwest from the Lake Oroville Dam through the city and then runs to the west and parallel to Highway 70 south of the city. The terrain and flora surrounding Oroville is diverse, with the North Table Mountain Ecological Reserve and surrounding buttes to the north, the Sierra Mountain foothills immediately to the east, orchards to the south, and rice farms and other agriculture to the west.

Most of Oroville is in the Wildland Urban Interface, which is defined as residentially developed areas that are adjacent to vegetation subject to wildfire. CalFire has mapped fire hazard zones throughout California. The Fire Hazard Severity Zone Map for the Oroville shows Moderate and High Fire Hazard Severity Zones bordering the north and east sides of the city, with some High Fire Hazard Severity Zones extending into eastern portions of the city. (CalFire Wildland Urban Interface Map, CalFire Fire Hazard Severity Zones Maps)

There are some air and noise pollution impacts to parts of Oroville from Highway 70, which runs north to south along the west edge of the city. There are very few residential neighborhoods adjacent to Highway 70, however.

According to the Federal Emergency Management Agency (FEMA) Flood Insurance Rate Maps (FIRM), significant areas within Oroville are in 100-year flood plain zones. These flood zones include areas on either side of the Feather River that flows through the city, which are Zone A Special Flood Hazard Areas. These areas are free of residential structures and consist of open space and parks. About a quarter of the urbanized area of the city are within Zone X Flood Hazard Areas. This flood hazard zone includes the northern part of the historic city center, extending to the western half of the historic city center parallel to the Feather River, and south parallel and to the east of the Feather River. There are also three pockets of Zone A Special Flood Hazard Areas on the east side of the city, and one pocket of Zone A Special Flood Hazard Area on the south side of the city. FEMA reevaluates flood zones as needed and floodplain designations may change in the future with changing conditions.

The National Wetland Inventory shows wetlands bordering the Feather River in areas outside urban development. Most of these wetlands are classified as Riverine System, with smaller portions classified as Palustrine System. There are also a few narrow Riverine System wetland areas extending from the center of the city to the eastern Sierra foothills, following along natural creek beds and channels that have intermittent flowing water.

### ***Infrastructure Capacity***

After conducting an assessment of the Sites Inventory above and infrastructure needs, it was determined that the City of Oroville has adequate infrastructure to support the development of the new residential units included in the Sites Inventory. More information about infrastructure and capacity is described below.

### **Water**

The City of Oroville is served by four different water utilities: South Feather Water and Power (SFWPA) serves the eastern and far south parts of the city; CalWater serves the western part of the city; the Thermalito Water and Sewer District (TWSD) serves the northern part of the city; and the Lake Oroville Area Public Utilities District (LOAPUD) serves small portions of the city on the south and southeast. Public water systems in California are regulated by the State Water Resources Control Board (SWRCB), Division of Drinking Water. Water Management Plans are required to be completed and adopted by water utilities every five years, per California Water Code Section 1, Part 2.55 and Part 2.6. Water network descriptions for the two major water suppliers for Oroville, SFWPA and CalWater, are summarized below.

SFWPA adopted a 2020 Urban Water Management Plan and a Water Shortage Contingency Plan in July 2021. The agency provides water to just over 6,800 households that use approximately 1,437 acre-feet of water annually. WFWPA maintains a service area of over 31,000 acres supplied by 141 miles of pipeline, and delivers irrigation water seasonally to over 500 customers via 110 miles of canals. Domestic water facilities consist of two treatment plants and four storage facilities that are sourced by the South Fork of the Feather River and Slate Creek, a tributary to the North Fork Yuba River, including reservoirs with a combined storage of 164,577 acre-feet. SFWPA participated in the development of the Northern Sacramento Integrated Regional Water Plan, which covers Butte County, and coordinates plans with the Butte County Department of Water and Resource Conservation. SFWPA does not have any current plans for major system upgrades or expansions.

CalWater adopted a 2020 Urban Water Management Plan in June 2021. CalWater's Oroville District operates a water system serving an estimated 10,849 residents with 3,547 municipal connections that use approximately 2,753 acre-feet of water annually. The system includes two storage tanks, six booster pumps, and 52 miles of pipeline supplied by the west branch of the Feather River and three groundwater wells. Supplemental water from the Thermalito Irrigation District is accessed when needed. CalWater participated in the development of the Northern Sacramento Integrated Regional Water Plan, which covers Butte County, and coordinates plans with the Butte County Department of Water and Resource Conservation. CalWater does not have any current plans for major system upgrades or expansions.

## **Sewer**

The City of Oroville Public Works Department operates a sanitary sewer collection system consisting of over 91 miles of main lines and seven lift stations that convey wastewater to a treatment plant owned and operated by the Sewerage Commission- Oroville Region, which is a joint powers authority that includes the TWSD and LOAPUD. Wastewater flow ranges from 0.85 million gallons per day (mgd) minimum dry weather flow to 11.27 mgd peak wet weather flow. The City adopted a Sewer System Management Plan in October 2009, in compliance with the Statewide General Waste Discharge Requirement. This plan describes management activities to effectively manage wastewater and reduce sanitary sewer overflows. A Sanitary Sewer Master Plan Update was adopted in January 2013 that evaluates the capacity of the existing wastewater collection system, proposes improvements to enhance system reliability and accommodate future growth, and calculate appropriate development impact and sewer service fees to support the Capital Improvement Program. The Capital Improvement Plan includes main line extensions and a new pump station that will cost a combined \$40.4 million.

## Storm Drainage

The City of Oroville Public Works Department manages the city's storm drainage system, which consists of approximately 60 miles of drainage pipes and trenches and six regional detention basins. The City's storm water infrastructure is engineered to protect residents from an extreme hydrologic event, also known as a 100-year storm event. The City's storm drain plans and management are regulated by the California State Water Resources Control Board and U.S. Environmental Protection Agency Storm Water Regulations. Planning and building permits require review by the City's Public Works Department for storm drainage impacts and management, and compliance with the City's Storm Water Pollution Prevention Plan (SWPPP). An adequately funded storm drainage infrastructure and compliance with state and federal regulations is particularly critical for the City of Oroville due to proximity to the Lake Oroville Dam, Feather River, and a number of identified 100-year floodplain areas, as described in the Environmental Constraints section above.

## Dry Utilities

Pacific Gas & Electric (PG&E) provides gas and electricity service to Oroville residents and businesses. The City coordinates with dry utility providers, including electricity, gas, telephone, and cable, during community master planning efforts and during the City's project entitlement and building permit process. Refuse service is provided by Recology. Telephone and DSL internet services are offered by AT&T and available to 79.76% of residents. Cable internet provided by Comcast is available to 75.60% of residents. Other companies provide internet access via fixed wireless systems, including Digitalpath.net, AT&T, Succeed.net, and CCI Wireless. These internet providers cover 98.69% of the city (BestNeighborhood).

## **AFFIRMATIVELY FURTHERING FAIR HOUSING: SITE INVENTORY**

---

In this section, sites included in the Site Inventory are identified, mapped, and evaluated on their capacity to Affirmatively Further Fair Housing. For the purposes of this analysis, the evaluation of fair housing includes patterns and trends of segregation and integration, racially and ethnically concentrated areas of poverty, access to opportunity, and disproportionate housing needs including displacement risk. The analysis includes data on the Regional Housing Needs Allocation (RHNA) and local data and knowledge, as well as a summary of conclusions and approach to policies and programs.

### *Isolation of RHNA*

“Figures 38, 38.1, 38.2: City of Oroville, Site Inventory Map” depicts nine sites which the City has identified for future development to meet the Regional Housing Needs Allocation (RHNA) requirements. The map represents approximate locations. The sites identified in this analysis have the potential to bring 262 units for very low-income and low-income households, 77 units for moderate income households, and 390 units for above moderate households, which surpasses the RHNA by 104 units. There are 85 surplus units for low and very low-income households, 4 surplus units for moderate income households, and 15 surplus units zoned for moderate and above moderate-income households.

The sites were chosen based on availability, zoning, and access to infrastructure. Figure 38: Site Inventory Map, 2022, depicts the location of the lower income sites (red), moderate income sites (yellow), and above moderate income sites (green) in the City.

Three of the four lower income sites are located in close proximity to one another at the City’s center, which is encompassed by Census Tract 28. The fourth lower income site is located at the north end of Census Tract 30.02, just south of the City’s center. Areas that are zoned for multi-family development are located near the city center, which has limited land for development, better access to infrastructure, and is more feasible for affordable housing development. This encourages higher density developments, such as apartments, which can naturally concentrate residents with low-incomes or experiencing poverty in these areas. The moderate income site is located in Census Tract 37, just above the City’s center. The two above-moderate income sites are located in Census Tracts 25 and 29. The above moderate site located in Census Tract 25 is just slightly north of the downtown area. The above moderate site located in Census Tract 29 is at the north end of the City. The capacity of these sites to affirmatively further fair housing is analyzed in the Improved Conditions and Exacerbated Conditions sections.

Figure 38: Site Inventory Map, 2022

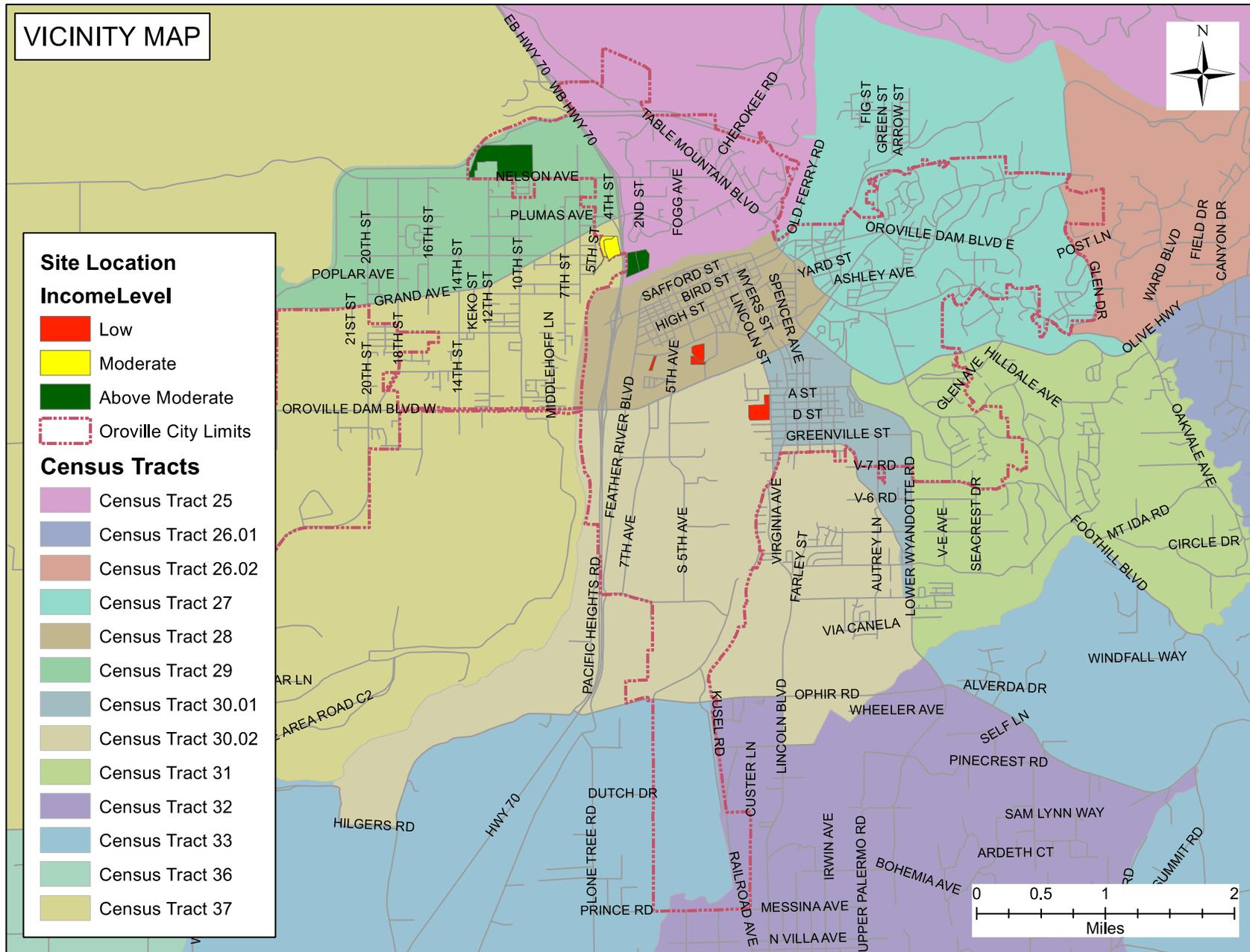

## ***Improved Conditions***

This section explores how the sites identified better integrates the community with a consideration for historical patterns and trends, number of existing households, and the impacts on patterns of socio-economic or racial/ethnic concentrations.

### **Racially or Ethnically Concentrated Areas of Poverty**

As described in the Assessment of Fair Housing, there are no HUD (U.S. Department of Housing and Urban Development) defined racially or ethnically concentrated areas of poverty (R/ECAP) in the City of Oroville. Racially or ethnically concentrated areas of poverty rely on a racial or ethnic concentration threshold and a poverty test. A racially or ethnically concentrated area of poverty is defined as an area that: 1) has a non-white population of 50% or more for urban areas and 20% for rural areas, and 2) 40% or more of the population lives below the poverty line (or those where the poverty rate is three times the average poverty rate of the metropolitan area). In addition, there are no racially concentrated areas of affluence, which are areas that have high concentrations of affluent, white residents. All census tracts within the City have a median income below the State's average.

### **Segregation and Integration**

This considers whether all the sites will receive the same amenities, whether the units are any combination of affordable, market-rate, rental, for-sale, multi-family, or single-family. It analyzes the opportunities for all income levels to reside in an area of new growth to improve fair housing choice and equitable access to opportunity.

One of the above-moderate sites is located in Census Tract 25, which is an area of high segregation and poverty, increased diversity, and has the most public housing buildings in the entire City. The moderate income site is located in Census Tract 37, which is an area with high segregation and poverty and an area with a high concentration of single mother households. Attracting moderate and above-moderate income residents to these areas improves integration of residents from various income backgrounds. It also improves the likelihood of integrating residents with different household characteristics and racial or ethnic backgrounds, as more affluent residents tend to be White, married-couple households. Residents who are low-income or are experiencing poverty can benefit from increased access to resources and services that is associated with new development.

Three of the low and very low-income sites are in Census Tract 28, which is also an area of high segregation and poverty. One site is located in Census Tract 30.02. Although this

attracts low-income residents to the area, both Census Tract 28 and Census Tract 30.02 have been identified as priority areas for investment. Because the region lacks adequate housing and resources, the introduction of new housing stock to the region will likely have a positive effect.

### **Access to Opportunity**

The location of sites in relation to educational opportunity, environmental score, economic opportunity, and transportation is analyzed below.

As mentioned, described in the Assessment of Fair Housing, “*Figure 22: City of Oroville, Access to Opportunity Map, 2021*” depicts that nearly all areas of the City are considered areas with low access to resources or areas experiencing high segregation and poverty, with the exception of Block Group 6 in Census Tract 27. The proposed moderate and above moderate income sites are located in Census Tract 25, 29, and 37, which would both benefit from investment. Attracting moderate and above moderate residents to low resource areas increases access to resources and investment in communities that need them the most. Areas of affluence tend to have higher educational outcomes. This could potentially increase the educational outcomes in Census Tract 25, 29, and 37.

The analysis of Access to Transportation, described in the Affirmatively Furthering Fair Housing section, concluded that there are no unmet transit needs that are reasonable to meet. Furthermore, because the low income and very low income sites are concentrated in the City’s center, low-income residents will benefit the best access to transit.

### ***Exacerbated Conditions***

This section explores how the sites identified further segregates the community with a consideration for historical patterns and trends, number of existing households, and the impacts on patterns of socio-economic or racial/ethnic concentrations.

### ***Disproportionate Housing Needs and Displacement Risk***

Both quantitative and qualitative data indicate that there is a significant population of very-low-income residents and a small population of high-income residents. Approximately 50% of households earn less than 35,000 and 18% of households earn more than \$75,000, which is greater than the area median income (\$70,700). Lastly, about 60% of households have two or fewer persons. Most residents are overpaying and areas to the northwest and southeast of

Oroville experience significant overcrowding. Anecdotally, South Oroville is known to be an area that experiences substandard housing conditions. Findings from the Assessment of Fair Housing indicate that 70% of residents who experience 1 of 4 Housing Problems or 1 of 4 Severe Housing Problems are renters and that trend is worsening.

As mentioned previously, 60-80% of the units in Census Tract 28 are renter-occupied units, which indicates that this neighborhood has a high concentration of rental units and more than 80% of renters are overpaying. In Census Tract 30.02, 40-60% of units are renter-occupied and 60-80% of residents are overpaying. The City should consider developing future, multi-family housing developments outside the City's center and redirect its effort to build owner-occupied housing in this region if deemed feasible. However, the moderate income site is located in Census Tract 37, where more than 80% of renters are overpaying. Attracting moderate income residents to this area will help encourage income diversity and current residents will benefit from improved access to resources.

The City should consider identifying future lower income sites in census tracts that do not experience high segregation and poverty or overcrowding, which include Census Tracts 27, 29, and 31. Lastly, the City could consider mixed-income developments to integrate residents from varying income backgrounds. However, because these affordable housing projects have the potential to bring 262 affordable units in census tracts where residents are historically overpaying, the benefits outweigh the costs.

## *Local Data and Knowledge*

### **Interview Summaries**

This section contains a summary of comments regarding housing in the City collected from the interviews discussed in the Assessment of Fair Housing.

Staff from the City of Oroville noted that there is a need for affordable housing and moderate and above moderate income housing. Many survivors from recent fires have relocated to the City but do not have a permanent place to live, placing a constraint on housing stock and availability. In addition, the City noted that a substantial amount of housing units are in need of repair or rehabilitation to meet health and safety standards.

Staff at Youth for Change noted that there is a need for studio, one-bedroom units, and large units with multiple bedrooms to meet the need of unhoused youth in the Butte County area. Legal Services of Northern California staff indicated that there is a need for supportive housing that provides wraparound services. In addition, there is a shortage of accessible units in the Butte County region. Staff from Stonewall Alliance Center reported that in Butte County there are few rental vacancies and a lack of assisted living facilities for residents with

severe mental health conditions, substance use disorder, or those experiencing homelessness.

Staff from the Disability Action Center noted that in Butte County low-income tenants could benefit from supportive services to complement housing. Staff also noted that there is a significant population of unsheltered individuals experiencing homelessness. Staff believes that local, State, and Federal administrative support in zoning and development application fees could incentivize low-income housing developments.

Interviews with staff from multiple organizations found that residents have difficulty finding housing that fits their needs and affordability, which includes one-bedroom or studio apartments and large homes with three or more bedrooms that can be shared by multiple tenants. North Valley Housing Trust noted that Northern California developers are having difficulty finding the finances or funds to get affordable housing projects off the ground. Policies such as the competitive public bid process, costly local utility requirements, or environmental reviews are especially prohibitive for small developers.

### ***Summary of Conclusions and Approach to Policies and Programs***

This section on Affirmatively Furthering Fair Housing in the Site Inventory focuses on improving fair housing choice and equitable access to opportunity. The low-income, very-low-income, moderate, and above moderate-income sites proposed by the City surpass the RHNA requirements by 85 units. The surplus of housing units will help meet the needs of fire survivors who have relocated to the region. Interviews with local agencies indicate that there is a need to create housing for all income levels, including affordable housing, small one-bedroom/studio units, permanent supportive housing, moderate and above moderate income housing, and shelters for those experiencing homelessness.

In the future, the City will consider developing very low and low income housing in areas that do not experience high segregation and poverty, such as Census Tracts 27, 29, and 31 to encourage more balanced and integrated living patterns. The City should also consider developing self-help housing or other forms of affordable, owner-occupied housing units in Census Tract 28, which has an unusually high concentration of rental units. Other approaches to improve fair housing choice and opportunity are reflected in the Goals, Policies, and Programs section.

The proposed sites in the Sites Inventory Analysis meet the requirements of residents in the region by providing an excess of housing units to meet the regional housing needs of each income group. In addition, new development in traditionally low-income and under-resourced areas improves access to education and jobs and will help revitalize neighborhoods.

## FINANCIAL INVENTORY

---

### *State Resources*

#### **Permanent Local Housing Allocation (Formula Funds)**

*Government Administrator/Application Process:* City of Oroville/City applies to HCD

*Eligible Uses:* A wide range, which includes but is not limited to—affordable rental housing for households below 80% AMI; affordable rental and ownership housing, including

Accessory dwelling units (ADUs), for households earning up to 120% of AMI; or capital costs for navigation centers and emergency shelters, as well as permanent and transitional housing for people experiencing homelessness.

*Current Status:* On-going funding provided through SB2 Building Homes and Jobs Act. Funding will fluctuate based on revenues taken in by the State.

#### **Permanent Local Housing Allocation (Competitive Funds)**

*Government Administrator/Application Process:* HCD/City applies to HCD in partnership with developer

*Eligible Uses:* New multi-family housing or rehabilitation of existing multi-family housing that is affordable to households at 60% AMI or less; permanent or transitional rental housing for those at risk of, or experiencing homelessness.

*Current Status:* On-going funding provided through SB2 Building Homes and Jobs Act. The State issues one NOFA each year.

#### **Multifamily Housing Program (MHP)**

*Government Administrator/Application Process:* HCD/Developer can apply

*Eligible Uses:* Deferred payment loan for housing developments with rents affordable to low-income households.

*Current Status:* State funding for this program is expected to be exhausted in 2021, but may be renewed in subsequent years through General Fund allocations and/or new bonds.

### **No Place Like Home (NPLH)**

*Government Administrator/Application Process:* HCD/Counties and Developers co- apply

*Eligible Uses:* Deferred payment loan for housing developments that target a portion of units to homeless individuals with mental illness. An operating reserve is also provided to awardees based on the number of NPLH-assisted units. In order to be eligible, counties must prepare a plan to address homelessness and commit to provide supportive services to tenants in NPLH-assisted units.

*Current Status:* A 2018 housing bond and revenue generated from the Mental Health Services Act (MHSA) funded \$2 billion for this program, with funding allocated through four different NOFAs released 2018-2021. The program may be refunded through State allocations and/or a new housing bond in future years.

### **Affordable Housing And Sustainable Communities Program (AHSC)**

*Government Administrator/Application Process:* HCD/Developer applies jointly with local transportation agency

*Eligible Uses:* Grants for infill low-income affordable housing, and infrastructure that encourages reductions in vehicle trips and greenhouse gas emissions.

*Current Status:* State program funded by greenhouse cap-and-trade program. Recent revisions to regulations encourage greater participation from rural communities.

### **Infill Infrastructure Grant Program (IIG)**

*Government Administrator/Application Process:* HCD/City or developer applies

*Eligible Uses:* Gap funding for infrastructure improvements necessary for specific residential or mixed-use infill projects.

*Current Status:* This is funding from Proposition 1, the Veteran's and Affordable Housing Bond Act, therefore this funding will sunset when all bond proceeds are disbursed. The State generally issues one NOFA each year.

### **Low-Income Housing Tax Credit Program (LIHTC)**

*Government Administrator/Application Process:* California Tax Credit Allocation Committee/Developer applies

*Eligible Uses:* New construction or rehabilitation of affordable housing; tax credits are purchased by investors that provide equity to projects

*Current Status:* Each state receives an allocation of federal tax credits for low-income housing. The California Tax Credit Allocation Committee administers allocations to affordable housing projects through a competitive application process. Most low-income affordable projects require the use of tax credits, as it typically provides the largest amount of funding.

### **Tax Exempt Revenue Bond Authority**

*Government Administrator/Application Process:* California Debt Limit Allocation Committee/Qualifying bond issuer applies on behalf of developer

*Eligible Uses:* New construction or rehabilitation of affordable housing; banks purchase bonds and make loans with below-market terms to projects

*Current Status:* Each state receives an allocation of debt from the federal government with interest earnings that are exempt from federal taxes. The California Debt Limit Allocation Committee administers allocations to affordable housing projects through a competitive application process.

## ***Federal Resources***

### **Community Development Block Grant (CDBG)**

*Government Administrator/Application Process:* HCD/City applies to HCD on a competitive basis

*Eligible Uses:* Housing— Single-Family Housing Rehabilitation, Homebuyer Assistance, Infrastructure in Support of Housing, Multi-family Housing Rehabilitation.

Community Development— Infrastructure improvements in low-income neighborhoods.

*Current Status:* The Biden Administration proposed to increase the funding for this program by 8.5%, while the Senate proposed a 20.1% increase, in the HUD Fiscal Year 2022 budget. The Fiscal Year 2022 budget had not yet been enacted as of January 2022. HCD administers an annual Notice of Funding Availability to competitively award these federal funds across the State in alignment with its HUD Consolidated Plan.

### **Home Investment Partnership Program (HOME)**

*Government Administrator/Application Process:* HCD/City applies to HCD on a competitive basis

*Eligible Uses:* New rental affordable housing; rehabilitation of existing rental affordable housing; down payment assistance programs to promote home ownership; owner-occupied housing rehabilitation; tenant-based rental assistance to prevent homelessness.

*Current Status:* The Biden Administration proposed to increase the funding for this program by 37.0%, while the Senate proposed a 7.4% increase, in the HUD Fiscal Year 2022 budget. The Fiscal Year 2022 budget had not yet been enacted as of January 2022. HCD administers an annual Notice of Funding Availability to competitively award these federal funds across the State in alignment with its HUD Consolidated Plan.

### **Housing Choice Vouchers (HCV)**

*Government Administrator/Application Process:* Housing Authority of the County of Butte (HACB), which receives HCV allocations from HUD/Tenants apply

*Eligible Uses:* Rental assistance for low-income households

*Current Status:* Local housing authorities receive funding for HCV (Section 8 of the United States Housing Act of 1937) from the Federal Government. As of 2021, HACB was administering six vouchers within the City of Oroville. While funding has been cut in recent years, the Biden Administration proposed to increase funding for this program by 8.3%, while the Senate proposed a 6.3% increase, in the HUD Fiscal Year 2022 budget. The Fiscal Year 2022 budget had not yet been enacted as of January 2022.

### **Project Based Section 8 Vouchers**

*Government Administrator/Application Process:* Housing Authority of the County of Butte (HACB), which receives HCV allocations from HUD/Developers apply

*Eligible Uses:* Rental assistance for low-income households tied to units, which can be underwritten by loans that finance housing projects

*Current Status:* Housing authorities may dedicate a portion of their Housing Choice Vouchers as Project Based Vouchers. The Biden Administration proposed to increase the funding for this program by 4.4%, while the Senate proposed a 3.8% increase, in the HUD Fiscal Year 2022 budget. The Fiscal Year 2022 budget had not yet been enacted as of January 2022.

### **HUD VASH Vouchers**

*Government Administrator/Application Process:* Housing Authority of the County of Butte (HACB), which receives HCV allocations from HUD/Tenants apply

*Eligible Uses:* Rental assistance and supportive services for homeless veterans

*Current Status:* This federally funded program is managed through a partnership between housing authorities and the U.S. Dept. of Veterans Affairs. Homeless veterans receive a rental subsidy from the housing authority and case management from the VA. HACB currently administers one VASH voucher in Willows. Funding for this program has been increasing in recent years with strong bipartisan support in Washington D.C.

### **Continuum Of Care (CoC) Programs**

*Government Administrator/Application Process:* Butte Countywide Homeless Continuum of Care/Lead Agency is the County of Butte, Department of Social Services, Housing and Homeless Branch

*Eligible Uses:* Rental subsidies, rapid re-housing, emergency shelter, homeless prevention

*Current Status:* The Butte Countywide Continuum of Care is currently accessing State resources available to them (Emergency Solutions Grant, Homeless Housing Assistance and Prevention, Homeless Emergency Aid Program, etc.) and Federal CoC funding through HUD. Funds are passed through to service providers at the County level. The Biden Administration proposed to increase the funding for this program by 16.7%, while the Senate proposed an 8.7% increase, in the HUD Fiscal Year 2022 budget. The Fiscal Year 2022 budget had not yet been enacted as of January 2022.

## OPPORTUNITIES FOR ENERGY CONSERVATION

---

As energy costs rise and nonrenewable resources are depleted, communities are utilizing energy conservation measures to offset rising costs. Typically, the use of alternative energy sources is most advantageous in new housing development. However, there are many energy-conserving measures that can be retrofitted onto older, existing housing which may conserve the ongoing use of nonrenewable fuels and reduce related costs. Low income families, especially seniors on fixed incomes, are most threatened, spending an average of 16.3% of their income on energy costs.

Energy Conservation programs available to residents of the City of Oroville include:

- Family Electric Rates Assistance (FERA)
- California Alternate Rates for Energy Program (CARE)
- Department of Energy (DOE) Weatherization Program
- Low Income Home Energy Assistance Program (LIHEAP)
- Affordable Housing for Sustainable Communities (AHSC)
- Disadvantaged Communities and Single-Family Solar Homes Program (DAC-SASH)
- Building Initiative for Low Emissions Development (BUILD)

### *Family Electric Rates Assistance (FERA)*

Residents can access energy, weatherization, and utility assistance through PG&E. PG&E provides a plethora of energy conservation services for residents. PG&E offers energy assistance programs for lower-income households to help community members conserve energy and reduce utility costs, which include the Family Electric Rates Assistance (FERA) and the California Alternate Rates for Energy Program (CARE). The FERA program, also administered by PG&E, offers monthly discount of 18% on electricity to households with three or more people. Participants qualify through income guidelines.

### *California Alternate Rates for Energy Program (CARE)*

The CARE program offers a monthly discount of 20% or more on gas and electricity to households with qualified incomes, certain nonprofit organizations, homeless shelters, hospices, and other qualified group living facilities. Participants qualify through income guidelines or if enrolled in qualified public assistance programs.

### *Department of Energy Weatherization Program*

A key providers of energy conservation services is the Community Action Agency of Butte County (CAABC). Community Action Department manages a variety of grant-funded programs, including emergency services, housing services, income and employment, and community services and development for vulnerable, low-income seniors, youth, and families. The CAABC administers a weatherization program funded by the Department of Energy for low-income residents, which is typically audit-driven. The weatherization upgrades must pay back in costs over the lifetime of the improvements to be permitted.

### *LIHEAP*

The CAABC also administers LIHEAP (Low Income Homeowner Energy Assistance Program), which is a federally funded program that services the City of Oroville. The program provides utility assistance, weatherization upgrades, and water heater or HVAC replacements to eligible, low-income households. The goal of the program is to assist low-income households with managing and meeting their immediate home heating and/or cooling needs and providing home weatherization upgrades. Both homeowners and renters in Butte County are eligible to participate in this program.

Residents are typically eligible for weather-stripping, low-flow showerheads and sink aerators, thermostatic shower valves, attic insulation, replacement of standard light bulbs and fixtures with energy efficient versions, and energy education. Qualified households may also receive assistance in paying their utility costs. This may include electric, natural gas, propane, heating oil, cord wood or wood pellets. Lastly, qualified households can receive heating, cooling, or water heater replacements. There are specific emergency services for clients who have received shut-off notices from their utility provider. Energy education helps residents learn more ways to reduce monthly energy bills.

LIHEAP is designed assist low-income households that pay a high portion of their income to meet their energy needs. Residents interested in any of these services can apply here to determine their eligibility: <https://www.caliheapapply.com/>. **Below is data on households who been serviced in the City of Biggs and Oroville through LIHEAP since 2010:**

- Homes weatherized between 2010 – 2019: 1076
- January – December 2020: 227
  
- Heating, Cooling, and/or Water Heater replacements made between 2010 – 2019: 321
- January – December 2020: 55
  
- Utility Assistance for help with electric bills between 2010 – 2019: 8753
- Number of payments made as of June 2021: 1417

Residents and community members can learn more about energy services administered by CAABC on their website at <https://www.buttecaa.com/energy-environmental-services/>

### ***Affordable Housing for Sustainable Communities (AHSC)***

Administered by the Strategic Growth Council and implemented by the Department of Housing and Community Development (HCD), the AHSC Program funds land-use, housing, transportation, and land preservation projects to support infill and compact development that reduce greenhouse gas ("GHG") emissions. Funding for the AHSC Program is provided from the Greenhouse Gas Reduction Fund (GGRF), an account established to receive Cap-and-Trade auction proceeds.

### ***Disadvantaged Communities and Single-family Solar Homes Program (DAC-SASH)***

AC-SASH is a ratepayer-funded program through the California Public Utilities Commission that provides up-front rebates to help low-income homeowners access the benefits of solar power. The DAC-SASH low-income solar program runs through 2030 in PG&E utility territory. In Orland, communities identified as "DACs" or disadvantaged communities in the state's CES 4.0 map will be eligible for the solar program based on geography. Households must still qualify based on income, owner occupancy and be connected to PG&E 's electric grid.

Under the original SASH fund, GRID Alternative installed systems on over 5,200 homes in California. GRID is a leading voice in low-income solar policy and one of the nation's largest nonprofit solar installer, serving families throughout California, Colorado, the Mid-Atlantic region, and tribal communities nationwide. GRID also offers single-family, multifamily and community solar installation services, project development and technical assistance, along with multiple levels of workforce development and service-learning opportunities, from volunteerism to in-depth solar training and paid internships. GRID's mission is to build community-powered solutions to advance economic and environmental justice through renewable energy.

DAC-SASH goals include:

- Maximize financial savings for low-income households in economically and environmentally disadvantaged communities.
- Enhance long-term economic self-sufficiency in low-income communities by providing community members with access to green jobs training and solar employment opportunities.

- Provide education on energy efficiency and existing programs that can provide further benefits to families.

### ***Building Initiative for Low Emissions Development (BUILD)***

Authorized by State of California Senate Bill 1477, the Building Initiative for Low-Emissions Development (BUILD) Program will provide incentives for the deployment of near-zero emissions building technologies in low-income residential buildings emissions significantly beyond what otherwise would be expected to result from the implementation of the prescriptive standards described in Part 6 of Title 24 of the California Code of Regulations (California Energy Code).

The BUILD Program is currently under development, with program goals to raise awareness of near-zero-emission building technologies and applications, test program and policy designs, and gain practical implementation experience and knowledge. The program is designed to be a market transformation program. Through outreach, technical support, and education, BUILD hopes to promote all electric building decarbonization. The first two years of the program is expected to be focused on affordable housing. In the City of Orland, there may be incentive funding for disadvantaged communities. BUILD program guidelines will be finalized by the Fall 2021 and launched by the end of 2021.

## CHAPTER 6: CONSTRAINTS ANALYSIS

This section analyzes how governmental policies and procedures, and market factors, may constrain housing development in Oroville. It also includes an assessment of the extent to which identified constraints impact residential production. Some of these constraints are addressed by Goals, Policies and Actions in the Chapter 3 Housing Program.

### GOVERNMENTAL CONSTRAINTS

---

State Housing Element Law requires that local governments facilitate and promote the provision of housing affordable for all economic segments of the community. While the City does not develop or build housing, local government can establish a regulatory framework that is conducive to the production of housing. On the other hand, some governmental regulations can increase the cost of development and thus constrain the availability of affordable housing. Governmental constraints can increase costs by adding specific expenses to building costs, such as street improvements or impact fees, or by increasing development timelines and thereby increasing the builder's incidental costs such as interest payments, property holding costs, or labor. Efforts to modify processes to alleviate constraints may require collaboration with the County of Butte because the County administers building permits for residential projects proposed within the City of Oroville jurisdiction. The City provides information about zoning code, development standards and fees on its website in conformance with Government Code 65940.1(a)(1).

Governmental constraints can be classified in three basic categories: those which pose regulation; those which add direct costs; and those which result in time delays. Regulations and time delays result in increased costs, but they cannot be calculated as easily as direct costs such as fees. The most significant factors falling within the influence of local government are:

- Land use controls
- Site improvement requirements
- Building codes and their enforcement
- Fees and exactions
- Permit processing procedures
- Accommodations for persons with disabilities

## General Plan

The City of Oroville adopted its 2030 General Plan in March 2015. The General Plan describes how the City has regulatory authority over land use within its jurisdictional boundaries, and is also permitted by law to establish future land use designations for areas outside its jurisdictional boundaries that are within its Sphere of Influence (SOI). The General Plan illustrates an abundance of vacant land within the City limits and within the SOI that is zoned for residential uses. Other relevant plans that guide the City of Oroville's development include the Airport Land Use Compatibility Plan, the Riverfront Master Plan, and the Community of South Oroville Redevelopment/Annexation Feasibility Study, which examines issues around annexing the South Oroville area that was outside the city boundaries as of the adoption of the General Plan. The document identifies the Rio d'Oro, Oro Bay, and unincorporated South Ophir Specific Plan Areas as potential areas for future annexation.

The General Plan also includes general plan designations for land uses. These general plan designations, and related land use controls and regulations, are described in this section. The General Plan states that within the city limits there are 63 acres of land designated for High Density, 151 acres of land designated Medium High Density Residential, 105 acres designated for Medium Density, 1,952 acres designated for Medium Low Density Residential, 278 acres designated for Low Density Residential, 24 acres designated for Very Low Density and Rural Residential, and 953 acres designated for Mixed Use.

Below is a listing of the residential Land Use Designations and associated densities established in the General Plan.

- Rural Residential (RR)— 0-0.2 dwelling units/acre
- Very Low Density Residential (VLDR)— 0.2-1 dwelling units/acre
- Low Density Residential (LDR)— 1-3 dwelling units/acre
- Medium Low Density Residential (MLDR)— 3-6 dwelling units/acre
- Medium Density Residential (MDR)— 6-14 dwelling units/acre
- Medium High Density Residential (MHDR)— 14-20 dwelling units/acre
- High Density Residential (HDR)— 20-30 dwelling units/acre
- Mixed Use (MU)— 10-30 dwelling units/acre (up to 70 dwelling units/acre in Downtown Mixed Use zoning designation based on provision of amenities per Policy 2.8 in the Land Use Element)

## Residential and Mixed-Use Zoning Districts

As shown in "Figure 39: Residential Zoning Districts," the City of Oroville's residential zoning districts allow for a range of housing types. Single-family dwellings are allowed by-right in all the residential zoning districts except R-3, R-4, and RP. Multi-family dwellings are allowed by-right in

R-2, R-3, R-4, RP, MXN, and MXC zoning districts, and in the MXD zoning district on stories above ground floor commercial uses.

Figure 39: Residential Zoning Districts

Zoning District	General Plan Designation	Units Per Acre	Max. Lot Coverage	Max. Height (ft.)	Min. Lot Size (sf)
Rural residential one acre (RR-1)	RR	0-0.2	10,000 sf	40	43,560
Rural residential 20,000 sf (RR-20)	RR	0-0.2	40%	40	20,000
Rural residential 10,000 s (RR-10)	RR	0-0.2	40%	35	10,000
Large-lot residential (RL)	LDR	1-3	40%	30	8,000
Single-family residential (R-1)	MLDR	3-6	50%	30	5,000
Medium-density residential (R-2)	MDR	6-14	60%	35	3,000
High-density residential (R-3)	MHDR	14-20	65%	45	2,200
Urban-density residential (R-4)	HDR	20-30	70%	50	2,000
High-density residential/professional (RP)	MU	10-30	65%	45	2,200
Downtown Mixed-Use (MXD)	MU	10-70	2.0-3.5 FAR*	55	N/A
Neighborhood Mixed-Use (MXN)	MU	10-30	1.0 FAR	40	N/A
Corridor Mixed-Use (MXC)	MU	10-30	1.0 FAR	60	N/A

Source: City of Oroville Municipal Code, Chapter 17.28 and 17.34

The Residential Use Table for the Residential Zoning Districts is shown in Figure 39.1 below. The symbols used in Tables 39.1-39.3 have the following meanings:

- P** Permitted use, zoning clearance required
- A** Administrative permit required
- UP** Use permit required
- S** See use-specific regulations for permit requirement
- Blank** Use not allowed

Figure 39.1: Residential Zoning Districts Use Table

Residential Use	Permit Requirement For Zone					
	RL	R-1	R-2	R-3	R-4	RP
Boardinghouse				UP	UP	UP
Duplex			P	P	P	P
Emergency shelter				P	P	
Mobile home park	UP	UP	UP	UP	UP	UP
Multiple-family dwellings			P	P	P	P
Residential care facility- 6 units or fewer	P	P	P	P	P	P
Residential care facility- 7 units and more				UP	UP	
Second dwelling unit	AP	AP	AP	AP	AP	AP
Single-family dwelling, attached			P	P	P	P
Single-family dwelling, detached	P	P	P			
Single-family manufactured on permanent foundation	P	P	P			
Single-room occupancy				UP	UP	
Transitional housing				UP	UP	

Source: City of Oroville Municipal Code

The Residential Use Table for the Mixed Use Zoning Districts is shown in Figure 39.2 below. Mixed-use development is defined as including nonresidential uses on the ground floor of each street frontage while also including residential uses for up to 75% of the allowed floor area ratio, and is permitted by right in all Mixed Use Zoning Districts. Residential uses in the Downtown Mixed Use district are permitted only on upper stories above ground floor commercial uses. Also note that for Downtown Mixed-Use (MXD), the density can be up to 70 units per acre and up to

3.5 Floor Area Ratio based on the provision of amenities such as improving wayfinding in the Downtown; providing pedestrian, bicycle, or transit amenities; providing arts or cultural amenities; or incorporating programs to reduce commute trips, prevent crime, or improve sustainability.

Figure 39.2: Mixed Use Zoning Districts Residential Use Table

Residential Use	MXD	MXN	MXC
	Caretaker residence	UP	UP
Mixed-use development	P	P	P
Multiple-family dwellings	P(1)	P	P
Residential care facility- 6 units or fewer	P	P	P
Residential care facility- 7 units or more	UP	UP	

Note: (1) Residential uses permitted only on upper stories above ground floor commercial uses.

Source: City of Oroville Municipal Code

**Commercial Zoning Districts**

Commercial Zoning Districts include the following:

- CN— Neighborhood commercial
- C-1— Limited commercial
- C-2— Intensive commercial
- CH— Highway commercial corridor
- CLM— Commercial/light manufacturing
- OF— Office

The Residential Use Table for the Commercial Zoning Districts is shown in Figure 39.3 below.

**Figure 39.3: Commercial Zoning Districts Residential Use Table**

Residential Use	CN	C-1	C-2	CH	CLM	OF
Caretaker residence	UP	UP	UP	UP	UP	
Residential care facility- 6 units or fewer	P	P	P	P	P	
Residential care facility- 7 units or more						

**Overlay Zones**

The Planned development overlay district (PD-O) encourages maximum flexibility in site planning relating to design, clustering of development, and protecting environmental resources, while encouraging: innovation and development of affordable housing, particularly on properties with environmental constraints, natural resources, or other topographical, geographical, or public improvement and service-related constraints; protecting the public health, safety, and general welfare of the city; and ensuring consistency with the General Plan, applicable Specific Plans, and any design guidelines adopted by the City Council. Development standards may be adjusted or modified in this overlay district where necessary and justifiable, and in compliance with minimum fire safety standards, with exception of the maximum density and Floor Area Ratio (FAR).

**Density Bonus**

California’s Density Bonus Law (Government Code Section 65915) allows developers to request density bonuses and concessions based on the percentage of affordable units in the proposed project. Before 2021, the maximum density bonus was 35% for housing projects, which included either 11% Very Low-income units, 20% lower income units, or 40% moderate income units. Recent legislation (AB 2345) increased the top range of the density bonus to 50% for housing projects with 15% Very Low-Income units, 24% lower income units, or 44% Moderate-Income units. AB 2345 does not modify the 80% density bonus required to be provided to 100% affordable projects. In addition to the density bonuses, projects meeting the affordability thresholds described above are entitled to one or more incentives or concessions, which could

include exceptions to building standards such as setbacks or building coverage ratios. In addition, AB 2345 amends parking ratios for qualifying projects to one space per studio or one-bedroom unit, 1.5 spaces per two-bedroom or three-bedroom unit, and 2.5 spaces per four-bedroom unit. Further reductions in parking standards are allowed for projects within a half-mile radius of a major transit stop, and for senior housing with paratransit service or access to a bus route that operates at least eight times per day.

The City of Oroville Density Bonus provision is located in Chapter 17.24 of the Municipal Code. Section 17.24.010 states that in the event of any conflict between Chapter 17.24 and Section 65915 of the State Government Code, the provisions of the Government Code shall apply.

### Parking Requirements

The City's parking standards for residential development are found in Section 17.12.070 of the Municipal Code. Parking requirements are based on the number of units, bedrooms, or beds, depending on the housing type, as outlined below. For residential development, the off-street parking requirements are listed below:

- Single-family dwellings — 2 spaces per unit
- Duplex — 2 spaces per unit
- Triplex— 1 space for one bedroom units; 1.5 spaces for two or more bedroom units
- Multi-family— 1 space for studios and one-bedrooms; 2 spaces for two or more bedroom units if <14 units/acre; 1.5 spaces for two or more bedroom units if >= 14 units/acre; 1 guest space per 4 units
- Boardinghouses — 1 space per bedroom
- Caretaker dwelling unit — 1 space per unit
- Emergency shelter — 1 space per 10 adult beds
- Residential care facility for 6 persons or fewer— same as requirements for applicable type of dwelling unit
- Residential care facility for 7 persons or more — 1 space per 3 beds
- Second dwelling unit — 1 space per unit

### Required Setbacks

For the RR-1, RR-20, and RR-10 zoning districts, minimum front and rear setbacks are 20 feet, and minimum side setbacks are 10 feet. For the RL zoning district, minimum front and rear setbacks are 20 feet, and minimum side setbacks are 5 feet or 10 feet along any street frontage.

For the R-1 zoning district, the minimum front setbacks are 15 feet and 20 feet for garages, minimum rear setbacks are 20 feet, and minimum side setbacks are 5 feet or 10 feet along any street frontage. For the R-2, R-3, R-4, and RP zoning districts, the minimum front setbacks are 10 feet and 20 feet for garages, minimum rear setbacks are 20 feet, and minimum side setbacks are 5 feet or 10 feet along any street frontage. For the MXD zoning district, the minimum front setback is 0 feet and the maximum front setback is 5 feet, the minimum rear setback is 10 feet, and the minimum side setback is 10 feet if adjacent to a residential zone or 0 feet if adjacent to other uses. For the MXN and MXC zoning districts, there are no setback requirements unless adjacent to residential uses, in which case the minimum front setback is the same as for the adjacent residential zoning district, the minimum rear setback is 20 feet, and the minimum side setback is 10 feet.

### **Site Coverage Ratio and Floor Area Ratio**

Site Coverage is a ratio of the building footprint square footage to lot square footage. Floor Area Ratio (FAR) is the ratio of total building square footage to lot square footage. For example, a two-story building that covers the entire lot area would have a 2.0 FAR. For Oroville, site coverage is applied to residential zoning districts, with a maximum site coverage ratio of 40% to 70%, and FAR is applied to mixed-use zoning districts, with a maximum FAR of 1.0 to 3.5.

### **Growth Controls**

The City does not have any growth controls or caps on the number of units that can be built over a designated period of time, in conformance with SB 330. The 2030 General Plan, municipal code, and design guidelines adequately support community character and public safety. City expansions through annexations must be reviewed and approved by the Butte County Local Agency Formation Commission (LAFCo), which is a countywide commission established by the State of California to ensure the orderly formation of local government agencies, the preservation of agricultural lands and open space, limitation of urban sprawl, and efficiency in local government services. The City does not have any inclusionary requirements. The City is in compliance with the Housing Accountability Act.

### **Zoning for a Variety of Housing Types**

Zoning codes should provide adequate flexibility for the development of a variety of housing types that meet the range of needs documented in the Chapter 4 Needs Assessment. These housing types help meet residents' needs according to income, age, current housing status, household size, and employment. Below is a description of how the City of Oroville zoning code

accommodates each housing type listed below and where amendments to the zoning code are needed to comply with Government Code Section 65583(a)(4), (c)(1), and subdivision 65583.2(c).

***Multifamily Rental Housing***— allowed by-right (without discretionary permit review) in the R-2, R-3, R-4, RP, MXN, and in the MXD zoning district on stories above ground floor commercial uses. Incentives to allow greater densities, exceptions to development standards, and design flexibility are provided through the PD-O Overlay and the Density Bonus. Muni Code Section 17.040.060 defines a "family" as a "household" and "household" is defined as: "Household. One or more persons, whether or not related by blood, marriage or adoption, sharing a dwelling unit in a living arrangement usually characterized by sharing living expenses, such as rent or mortgage payments, food costs and utilities, as well as maintaining a single lease or rental agreement for all members of the household and other similar characteristics indicative of a single household." This definition does not cause a constraint to housing development since this definition of "Family" is not restricted beyond persons sharing a housing unit (i.e. requirements that the persons are related by blood or marriage).

***Housing for Agricultural Employees***— This housing type is not defined in the Municipal Code, nor is it identified as a permitted use for residential zoning districts. Program 2.1.5 describes how the Municipal Code will be amended to add a provision for Agricultural Worker Housing consisting of six or fewer persons is permitted as a by-right use in all residential zoning districts, in compliance with Health and Safety Code 17021.5. There are no agricultural zoning districts in Oroville that would apply to Health and Safety Code 17021.6 or 17021.8.

***Low Barrier Navigation Centers***— Low Barrier Navigation Centers are facilities that connect people experiencing homelessness to permanent housing through on-site services. State Law, per AB 101, requires that local government jurisdictions allow Low Barrier Navigation Centers by right in areas zoned for mixed uses and nonresidential zones permitting multifamily uses if it meets specified requirements. The City of Oroville Zoning Code does not include Low Barrier Navigation Center as a defined residential use. Therefore, Program 1.2.2 has been included in the Chapter 3 Housing Program to amend the zoning code in order to comply with AB 101.

***Transitional Housing***— Transitional housing is defined in Section 50675.2 of the Health and Safety Code as rental housing for stays of at least six months but where the units are re-circulated to another program recipient after a set period. The City's Municipal Code currently includes Transitional housing in its definitions section of the City Municipal Code, Section 17.04.060 consistent with Health and Safety Code Section 50675.2. Transitional Housing is only allowed with a Conditional Use Permit in the R-3 and R-4 zoning districts. In order to comply with Health and Safety Code Section 65583, Transitional Housing must be treated no differently than other residential uses and allowed by-right in all residential zoning districts. Therefore, Program 2.1.6 has been included in the Chapter 3 Housing Program to amend the zoning code in order to comply with State Law.

**Supportive Housing**— Supportive housing is defined by Section 50675.14 of the Health and Safety Code housing with linked on-site or off-site services with no limit on the length of stay and is occupied by a target population as defined in Health and Safety Code Section 53260 (i.e., low-income person with mental disabilities, AIDS, substance abuse or chronic health conditions, or persons whose disabilities originated before the age of 18). Services linked to supportive housing are usually focused on retaining housing, living and working in the community, and/or health improvement. The City’s Municipal Code does not include Supportive Housing as a permitted use. In order to comply with Health and Safety Code Section 65583, Supportive Housing must be treated no differently than other residential uses and allowed by-right in all residential zoning districts. Therefore, Program 2.1.7 has been included in the Chapter 3 Housing Program to amend the zoning code in order to comply with State Law.

**Single-Room Occupancy Units**— The City’s Municipal Code, Section 17.04.060 defines Single-Room Occupancy (SRO) as “Housing (consisting of single room dwelling units with a minimum size of 150 square feet) that is the primary residency of its occupant or occupants. The unit must contain either food preparation or sanitary facilities if the project consists of new construction, conversion of non-residential space, or reconstruction. For acquisition or rehabilitation of an existing residential structure or hotel, neither food preparation nor sanitary facilities are required to be in the unit. If any unit does not contain food preparation or sanitary facilities, the building must contain those facilities in a common area shared by tenants.” SRO units are allowed with a Conditional Use Permit in the R-3 and R-4 zoning districts.

**Manufactured Homes**— The City’s Municipal Code, Section 17.04.060, defines a Manufactured Home in accordance with Section 18007 of the Health and Safety Code. Government Code 65852.3 requires that manufactured homes on foundation systems, as defined in the statute, are allowed by-right on lots zoned for conventional single-family residential dwellings. Manufactured Homes on permanent foundations are allowed by-right in all residential zoning districts except R-3, R-4, and RP. Manufactured Homes are also an allowable Second Dwelling Unit as defined in the Municipal Code.

**Mobile Homes and Mobile Home Parks**—As defined in the City’s Municipal Code, Section 17.04.060, Mobile Home is defined in accordance with 18008 of the Health and Safety Code. It is defined as “a structure transportable in one or more sections, designed and equipped to contain no more than two dwelling units to be used with or without a foundation system.” Mobile Home Parks are defined in the City’s Municipal Code, Section 17.04.060 as “any area or premises where space or mobile homes is rented, held or rent or on which free occupancy is permitted to house trailer owners and users for the purpose of securing their trailer, but not including automobile or trailer dealerships on which unoccupied house trailers are parked for inspection or sale.” Mobile home parks are allowed with a Conditional Use Permit in all residential zoning districts.

## Accessory Dwelling Units (ADUs)

Accessory Dwelling Units (ADUs), also known as granny flats, in-law units, backyard cottages, or secondary units, are attached or detached dwelling units with complete independent living facilities that are built on the same parcel as an existing main dwelling unit. They are a flexible housing type that can be more affordable to build because they are smaller in size than the typical dwelling unit, and do not require acquisition of a separate lot and construction of new complimentary improvements such as off-street parking. On January 1, 2020, six new bills intended to promote the development of ADUs became State Law. Five of the bills limit the ability of local government to restrict the development of ADUs in a variety of ways. They also set the rules for counting ADUs in a city's Adequate Site Inventory for the purpose of meeting RHNA in the Housing Element. The sixth law, AB 671, requires local government Housing Elements to include a plan to incentivize and promote the development of ADUs at affordable rents to Very Low-, Low- or Moderate-Income households.

Second Dwelling Units are defined in Municipal Code, Section 17.04 as "an attached or detached dwelling unit that is provided as an adjunct to an existing single-family dwelling unit and that includes complete, independent living facilities, including, but not limited to, an efficiency unit as defined in Section 17958.1 of the Health and Safety Code, or a manufactured home, as defined in Section 18007 of the Health and Safety Code." Second dwelling units are allowed with an Administrative Permit in all residential zoning districts. Administrative permits are ministerial and can only be denied if a project does not meet the applicable development standards. Applicable development standards are outlined in Section 17.16.010 of the Municipal Code. The City's Second Dwelling Unit standards will need to be modified in order to meet the latest updates to State ADU law. Program 2.1.8 in the Chapter 3 Housing Program establishes a program for updating the City's Second Dwelling Unit section of the Municipal Code to conform with State Law. In addition, Program 1.2.6 will develop a program that offers incentives to property owners who develop ADUs that offer affordable rents for very-low, low-, and moderate-income households, with recorded regulatory restrictions on rents.

## Emergency Shelters

California Health and Safety Code (Section 50801) defines an emergency shelter as "housing with minimal supportive services for homeless persons that is limited to occupancy of six months or less by a homeless person." In compliance with Government Code Section 65583(a)(4), emergency shelters are allowed by-right in the R-3 and R-4 zoning districts. There are currently two Emergency Shelters in Oroville.

AB 139 requires that local governments use their most recent Point-In-Time Homeless Census to determine whether there is adequate capacity in Zoning Districts where emergency shelters are permitted by-right. If adequate capacity is not available in these Zoning Districts, the jurisdiction must allow emergency shelters by-right in another Zoning District in order to provide adequate

capacity to meet the need. The 2019 Point-In-Time Homeless Census counted 415 individuals experiencing homelessness in Oroville. The 2030 General Plan estimated as of 2015 that there were about 1,635 acres of vacant residential land in the Oroville. Approximately 8.3% of the City's residential land has High Density and Medium High Density Residential Land Use Designations that correspond with the R-3 and R-4 zoning districts. Applying the 8.3% share of R-3 and R-4 zoned land to the 1,635 vacant acres yields 136 acres. Based on the size of other emergency shelter improvements and land, it is estimated that two 108-bed shelters would conservatively require about four acres each, for a total of eight acres. If it is assumed that all 415 individuals counted in the 2019 Point-In-Time Homeless Census were served in two emergency shelters in Oroville, there would be more than adequate space to shelter them within the vacant 136 acres of the R-3 and R-4 zoning districts. As emergency shelters are allowed by right in these two zones with more than adequate capacity, City of Oroville regulations are not a constraint to the development emergency shelters.

AB 139 also requires local governments to ensure that emergency shelter parking standards do not require any parking spaces beyond what is necessary for staff that work at the shelter. Program 2.1.9 of the Chapter 3 Housing Program describes how the City will amend its parking standards in order to comply with AB 139.

### **Extremely Low-Income Households**

As described in Chapter 4, there are a large number of Extremely Low-Income households in Oroville that have a variety of housing needs. Some Extremely Low-Income households include persons experiencing homelessness or near-homelessness, persons with substance abuse problems, or persons with disabilities. Housing types that may be appropriate for this population include the housing types described above, or one of the following housing types, with City of Oroville zoning code permitting requirements described:

*Boardinghouses*— defined in Municipal Code Section 17.04.060 as a building or portion of a building, other than a temporary lodging facility such as a bed and breakfast, hotel or motel, where sleeping facilities and meals for five or more persons are provided for compensation on a regular basis, are permitted with a Conditional Use Permit in the R-3, R-4, and RP zoning districts.

*Residential Care Homes*— defined in Municipal Code Section 17.04.060 in accordance with Section 1502 of the Health and Safety Code, with six or fewer clients are permitted by-right in all residential zoning districts, all mixed-use zoning districts, and all commercial zoning districts except the OF zoning district. This meets the requirements of Health and Safety Code Sections 1267.8(g), and 1566.3. Residential Care Homes with seven or more clients are permitted with a Conditional Use Permit in the R-3, R-4, MXD, and MXN zoning districts.

## Persons with Disabilities

As part of a governmental constraints analysis, housing elements must analyze constraints upon the development, maintenance, and improvement of housing for persons with disabilities, per California Government Code Section 65583(a)(4). The Housing Element must demonstrate local efforts to remove any such constraints and provide for reasonable accommodations for persons with disabilities through programs that remove constraints.

### *Residential Care Homes*

In accordance with the Community Care Facilities Act, the Oroville zoning code permits Residential Care Homes for six or fewer residents by-right in all residential districts. Residential Care Homes with seven or more clients are permitted with a Conditional Use Permit in the R-3, R-4, MXD, and MXN zoning districts. The use permits are approved if they meet the following seven findings: 1) not detrimental to general health, safety or public welfare of surrounding area or the city as a whole; 2) suitable location with regard to transportation facilities, public services, and other land uses in the vicinity; 3) adequate infrastructure; 4) compatible with surrounding neighborhood and not adversely affecting abutting properties; 5) site is physically suitable for the proposal; 6) provides services that are necessary or desirable for the community; and 7) permit complies with all applicable laws and regulations, including the General Plan and the City Municipal Code. On February 15, 2022, the City Council heard a presentation outlining this regulatory process and heard testimony from several owners/operators of supportive and other housing types, and did not find an impetus to make any changes at this time. There are no development standards that regulate the concentration or spacing of residential care homes. Constructing a new facility or structurally modifying an existing facility would require a building permit.

### *Reasonable Accommodation*

The City of Oroville has a Reasonable Accommodation provision in Section 17.08.160 of its Municipal Code. It is intended to provide equal access to housing throughout the city regardless of an individual's physical or mental abilities. The provision enables a disabled person to file a request for reasonable accommodation variance from Municipal Code with the Zoning Administrator. The criteria for approval of reasonable accommodation include: (1) applies only to the specific disabled person; (2) the accommodation is subject to all uniform building codes as adopted by the city; (3) changes affecting building exteriors are designed to be substantially similar to the architectural character, colors, and texture of materials of its surrounding dwelling units; and (4) the accommodation does not run with the land and constitutes a permit issued to a specific disabled person.

The Zoning Administrator can approve the application without discretionary review by the Planning Commission or City Council. Any application denial must be accompanied by the reasons for denial.

### ***Building Code***

Standard requirements regarding accessibility for persons with disabilities are found in California's Title 24, which is enforced locally by the City's Community Development Department, Planning and Building Divisions. Special accessibility requirements are required for multi-family residential projects with three or more units.

### **Conclusion**

The City of Oroville General Plan policies and zoning code include a number of provisions that do not constrain development of housing or remove regulatory constraints. Adequate land is zoned for residential uses at a variety of densities, and development standards for zoning districts are adequately flexible and do not unduly increase the cost or decrease the feasibility for housing production. Emergency shelters are permitted by-right in two different residential zoning districts. Residential Care Homes housing six or fewer clients are allowed by-right in all residential zoning districts, as well as mixed-use zoning districts.

To further remove regulatory barriers to a variety of housing types for special needs groups, and meet Housing Element Law requirements, the City must take a number of additional steps that have been incorporated into the Chapter 3 Housing Program. These include:

- allowance for the development of Low Barrier Navigation Centers by-right in areas zoned for mixed uses and nonresidential zones permitting multifamily uses if they meet specified requirements (Program 1.2.2);
- revisions to Second dwelling unit standards to bring them in conformance with State Law (Program 2.1.8);
- implement incentives to property owners who develop ADUs that offer affordable rents for very-low, low-, and moderate-income households, with recorded regulatory restrictions on rents (Program 1.2.6)
- add a provision for Agricultural Worker Housing, and allow for this type of housing of six or fewer persons to be permitted by-right use in all residential zoning districts (Program 2.1.5);
- add a provision that treats Transitional Housing no differently than other residential uses and allow this housing type by-right in all residential zoning districts (Program 2.1.6);
- add a provision that treats Supportive Housing no differently than other residential uses and allow this housing type by-right in all residential zoning districts (Program 2.1.7); and

- amend parking standards for Emergency Shelters in order to comply with AB 139 (Program 2.1.9).

## Building Codes and Enforcement

Building standards are essential to ensure safe housing, although some codes and standards may constrain the development or preservation of affordable housing. The City currently uses the 2019 California Building Standards Code. This includes the California Electric Code, California Mechanical Code, and the California Plumbing Code. The Code Enforcement Division in the Community Development Department addresses code violations, interfaces with the general public to address concerns regarding code issues, removes abandoned vehicles, and cleans up blighted properties. Code enforcement is handled in response to community concerns and complaints. The City has a Multi-family Inspection Ordinance that identifies blighted and deteriorated housing stock and ensures the rehabilitation or elimination of housing that does not meet minimum building code and housing code standards, or is not safe to occupy.

## PERMITTING PROCESS

---

The City of Oroville has established a process for reviewing housing projects to make sure they meet the requirements of the City's Zoning Ordinance and the General Plan. Section 17.48 of the Municipal Code outlines the process for reviewing and approving different types of permits, which include: Use Permits (also known referred to in this document as Conditional Use Permits), Minor Use Permits, Administrative Permits, Variances, and Rezonings.

### *Use Permits*

The Use Permit submission, review and approval process follows the steps below.

- 1) The application and fee for Use Permit is submitted to the Zoning Administrator that includes the components as listed in Subsection E.1 of 17.48.010.
- 2) The Planning Commission holds a minimum of one public hearing to review the application, with a public notice provided 10 days before the hearing.
- 3) The Planning Commission may grant the Use Permit only upon making all of the findings listed in Subsection E.4 of 17.48.010. The Planning Commission may attach conditions to the use permit as deemed necessary to ensure compliance with the zoning code, general plan and to protect the public health, safety, and general welfare.

- 4) The Planning Commission written determination is issued to the applicant within 10 days of the public meeting in which the determination was made.
- 5) The applicant or any person dissatisfied with the Planning Commission determination may appeal to the City Council within 15 days after the determination as provided in 17.56.100.
- 6) Within 45 days of the filing of an appeal, the City Council holds a public hearing to consider the Planning Commission's action and the appeal. The City Council renders its decision within 30 days of the public hearing and provides immediate verbal notice of the decision. The City Council decision is final.

### ***Minor Use Permits***

A proposed project that is exempt from the California Environmental Quality Act (CEQA) may be reviewed as a Minor Use Permit. The Use Permit submission, review and approval process follows the steps below.

- 1) The application and fee for Minor Use Permit is submitted to the Zoning Administrator.
- 2) The Development Review Committee reviews the application.
- 3) The Zoning Administrator holds a public hearing to review the application, with a public notice provided 10 days before the hearing.
- 4) The Zoning Administrator approves or denies the application, and may attach conditions to the Minor Use Permit as deemed necessary to ensure compliance with the zoning code, general plan and to protect the public health, safety, and general welfare.
- 5) Applications may be referred to the Planning Commission if it is found to be necessary for further review or on appeal of the applicant or any person dissatisfied with the Zoning Administrator determination.

### ***Administrative Permits***

The Administrative Permit submission, review and approval process follows the steps below.

- 1) The application and fee for Minor Use Permit is submitted to the Zoning Administrator.
- 2) The Zoning Administrator approves or denies the application.

- 3) The Zoning Administrator's written determination is issued to the applicant within 10 days of the determination.
- 4) The applicant or any person dissatisfied with the Zoning Administrator determination may appeal to the Planning Commission within 15 days after the determination as provided in 17.56.100.
- 5) Within 45 days of the filing of an appeal, the Planning Commission holds a public hearing to consider the Zoning Administrator's action and the appeal. The Planning Commission renders its decision within 30 days of the public hearing and provides immediate verbal notice of the decision. If the Planning Commission's decision is not appealed to the City Council, the decision is final.

### ***Variances***

The Planning Commission has the authority to grant variances to the zoning code in order to prevent discrimination and undue hardship, and no variance is allowed to be granted that would provide a special privilege not shared by other property in the same vicinity. A variance does not permit any land use that is not allowed in the applicable zoning district. The Variance submission, review and approval process follows the steps below.

- 1) The application and fee for Variance is submitted to the Planning Commission.
- 2) The Planning Commission holds a minimum of one public hearing to review the application, with a public notice provided 10 days before the hearing.
- 3) The Planning Commission may grant the Variance only upon making all of the findings listed in Subsection E.3 of 17.48.080.
- 4) The applicant or any person dissatisfied with the Planning Commission determination may appeal to the City Council within 15 days after the determination as provided in 17.56.100.
- 5) Within 45 days of the filing of an appeal, the City Council holds a public hearing to consider the Planning Commission's action and the appeal. The City Council renders its decision within 30 days of the public hearing and provides immediate verbal notice of the decision. The City Council decision is final.

### ***General Plan Amendment/Rezone***

An amendment to the General Plan or a rezoning may be initiated by the Planning Commission, the City Council, or a request by one or more property owners affected by the proposed by the amendment. The request for General Plan Amendment or Rezone follows the steps below.

- 1) The application and fee is filed with the Planning Commission.
- 2) The Planning Commission holds a minimum of one public hearing to review the proposed General Plan Amendment or Rezone, with a 10-day public notice provided, which includes a mailing of the notice to the applicant, anyone who has requested a written notice, all property owners that own property within 300 feet of the property to be rezoned.
- 3) After reviewing the evidence, the Planning Commission submits its recommendation in written form to the City Council, which includes the reasons for the recommendation and the relationship of the proposed amendment to the adopted General Plan.
- 4) The City Council holds a public hearing to consider the matter and the Planning Commission's recommendation, with a public notice provided 10 days before the hearing.
- 5) The City Council approves, modifies, or disapproves the Planning Commission recommendation upon a majority vote of the City Council.

### ***Subdivision/Parcel Maps***

Subdivisions are governed by Title 16 of the Municipal Code. The Planning Commission is designated as the "advisory agency" per the Subdivision Map Act. The following process is used to review and approve subdivision map proposals. A Tentative Subdivision Map and Final Subdivision Map are required for all land subdivisions creating five or more parcels or five or more condominiums, with the following exceptions:

- The land before division contains less than five acres and each parcel created by the division abuts a maintained public street or highway and no dedications or improvements are required;
- Each parcel created by the division has a gross area of 20 acres or more and has approved access to a maintained public street or highway;
- The land consists of a parcel or parcels having approved access to a public street or highway which comprises part of a tract of land zoned for industrial or commercial development, and which has the approval of the City Council as to street alignments and widths;

- Each parcel created by the division has a gross area of 40 acres or more; or
- The land is to be subdivided solely for biotic and wildlife purposes, pursuant to Section 66418.2 of the Government Code.

The following steps are followed for reviewing and approving subdivision map proposals.

- 1) The applicant files a Tentative Map with the Zoning Administrator in accordance with Municipal Code Section 16.12.020.
- 2) The Zoning Administrator reviews the application and notifies the applicant of whether it is complete or incomplete within 30 days from the date of submission.
- 3) Within 5 days after the Tentative Map is deemed complete, the Zoning Administrator sends the Tentative Map to each agency that is entitled to review the map, as provided in Section 16.12.020.
- 4) Within 15 days of receiving the Tentative Map, each agency may submit recommendations to the Zoning Administrator for consideration before making a decision on the Tentative Map.
- 5) The City Engineer prepares a written report to the Planning Commission on the Tentative Subdivision Map, which shall consider the relationship of the Tentative Map to the zoning code, other city ordinances, the General Plan and applicable Specific Plans, and comments from other City departments and public agencies. The report recommends conditions to be placed on the Tentative Map. The report is provided to the applicant at least 5 working days prior to any hearing or action on the Tentative Map.
- 6) The Planning Commission holds a public hearing to review the Tentative Map within 30 calendar days after the application has been deemed complete and the City has certified the project's CEQA review and determination, with a public notice provided 10 days before the hearing. The Planning Commission reviews the submitted Tentative Map, the Zoning Administrator report, and any available recommendations from public agencies and other interested parties.
- 7) The Planning Commission approves as submitted by the applicant, approves with conditions, or disapproves the Tentative Map. Grounds for disapproval are laid out in subsection F. of 16.12.020. The Planning Commission's action is final unless appealed to the City Council as provided in Section 16.04.060. The Tentative Map is valid for 36 months after approval.
- 8) At any time before the expiration of an approved Tentative Map, the applicant presents a Final Map to the Zoning Administrator in accordance with Section 16.12.030.

- 9) The City Engineer reviews the Final Map, and if in compliance with code, it is signed by all parties required by the Subdivision Map Act.
- 10) The Zoning Administrator reviews and approves or disapproves the Final Map. The Zoning Administrator may not deny approval if the Final Map is consistent with the previously approved Tentative Map. Within 15 days of the Zoning Administrator action, the applicant may appeal to the City Council as provided in Section 16.04.060.
- 11) Upon final approval, the Final Map is sent by the City Clerk to the County Recorder for recording as specified in Sections 66464 and 66468 of the Government Code.

### ***Boundary Line Modification/Minor Land Division***

A request for boundary line modification or minor land division must be submitted to the Zoning Administrator in accordance with Municipal Code Chapter 16.32. After review of the application, the Zoning Administrator approves or disapproves the lot line adjustment pursuant to California Government Code Section 66412(d). The Zoning Administrator decision may be appealed by the applicant to the City Council as provided in Section 16.04.060.

### ***Development Review***

The purpose of Development Review is to allow the Development Review Committee (DRC) to review all discretionary development applications, such as General Plan Amendments, Rezones, Subdivision Maps, Conditional Use Permits, Variances, etc. In addition, DRC also reviews the design of new construction multi-family projects and single-family dwelling units within the historic area or Downtown Historic Overlay District (DH-O) in order to ensure compliance with the Municipal Code and harmony of appearance in the City's neighborhoods. The Development Review process follows these steps:

- 1) An application for Development Review is submitted in accordance with Municipal Code Section 17.52.030.
- 2) The DRC reviews the application in light of the requirements of the General Plan and any Specific Plan, as well as Municipal Code and any design guidelines adopted by City Council. The applicant may participate in the DRC meetings.
- 3) The DRC prepares a written report recommending approval, approval with conditions, or denial, unless the action is appealed as provided in Section 17.56.100.

- 4) Within 45 days of the filing of an appeal, the City Council holds a public hearing to consider the DRC's action and the appeal. The Planning Commission renders its decision within 30 days of the public hearing and provides immediate verbal notice of the decision. If the Planning Commission's decision is not appealed to the City Council, the decision is final.

### ***SB-35, Permanent Supportive Housing, and Navigation Centers***

The City does not have a specific procedure for SB-35 applications, or reviewing Permanent Supportive Housing planning permit applications, but will comply with SB-35 and AB 2162 as applicable. Navigation Centers are not currently defined or addressed in the City's Municipal Code, but will be added in order to comply with AB 101 as described in Program 1.2.2 in the Chapter 3 Housing Program.

### ***On- and Off-Site Improvement Standards***

Construction of street frontage are required to conform with the City of Oroville Construction Standards as published and made available on the City's website at <https://www.cityoforoville.org/services/public-works-department/engineering-division/improvement-standards>. Some of the key improvement standards are listed below.

- The standard residential street designs have a 60 foot right-of-way with 35-40 foot street width curb to curb, a 5-6 foot park strip, and a 4.5-5 foot sidewalk.
- The standard cul-de-sac design has a 120 foot right-of-way at the widest extent of the right-of-way with 97 foot street width curb to curb, a 6 foot park strip, and a 5 foot sidewalk.
- Curbs and gutters are required, and design specifications are part of the City's Construction Standards.

Additional subdivision improvements standards are found in the Municipal Code, Section 16.16.070 as follows:

- Any newly created block shall be no longer than 800 feet along any distance between two intersections, unless an exception is made based on topography or other factors as provided in Section 16.04.040.
- Cul-de-sac streets in a residential subdivision shall not exceed 600 feet in length and shall not serve more than 25 parcels.
- The centerlines of streets that extend along existing or planned streets must continue the centerlines of the existing streets as far as practical.

On- and off-site improvement standards are not considered a constraint to housing development. All multi-family projects have been able to access existing water and sewer infrastructure, and complete required street improvements.

### ***Historic Overlay Districts***

The downtown historic overlay district (DH-O) covers most of the downtown area and is found in the Oroville Municipal Code 17.44.040, which includes specific development standards for all residential building types. The district's goal is to encourage revitalization and a vibrant downtown. In addition to the applicable residential and commercial zoning, proposed projects are reviewed for compliance with section 17.44.040 by the Planning Commission, which acts as the Historic Advisory Commission.

### ***Estimated Time Between Planning Permit and Building Permit Submittal***

In the past year, existing developer/builder applicants who have been eligible to receive the state's 9% disaster tax credits for affordable housing have spent an average of 3-6 weeks preparing building permit applications once receiving entitlements. Applicants not motivated by the tax credit timetable typically take 12 weeks between planning permit approval and building permit submittal. In terms of the time it takes for the City to process permits, on average, Administrative Permits require 2.5 hours, Density Bonuses take 20 hours, Use Permits take 20-36 hours, Zone Change requests require 16 hours, Variance requests require 20 hours, and tentative subdivision maps take 16 hours.

### ***Conclusion***

The City of Oroville's planning and building permit review procedures require similar processing times to other Northern California cities. The City's permit review processes do not present a significant constraint to residential development. While project review has increasingly become a complex process, the City of Oroville continues to seek ways to make this process more efficient without sacrificing the public's welfare or safety.

## **FEES AND EXACTIONS**

---

Permit and Impact fees fund services necessary to carry out local government functions. Permit fees compensate local government staff for reviewing project proposals to ensure that they are

consistent with the General Plan, Municipal Code, and State Law. Impact fees fund capital improvements necessitated by the cumulative demand of development. A review of both of these types of fees are critical to this constraints analysis in order to determine whether the fees unduly add to the cost of development and thereby constrain the provision of housing.

### ***Permit Fees***

Permit fees include planning fees, building permit fees, and plan check fees. Planning fees are charged when an applicant submits a proposal for constructing or rehabilitating improvements. They compensate City staff time for reviewing the proposal. Building permit and plan check fees are charged to review the construction plans to ensure compliance with local and state building codes, and to inspect the project for habitability at completion. Planning Permit fees for the City of Oroville are listed in “*Figure 40: Planning Permit Fees,*” and Building Permit fees are shown in

Figure 40: Planning Permit Fees

Description	Fee
<b>PLANNING FEES</b>	
Administrative Permit	\$ 585.78
Amendment/Modification Fee (Use Permits, Variance, TSM, etc.)	\$ 1,024.09
Annexation	\$ 3541.30 (Deposit)
Appeal to City Council (Discretionary Items)	\$ 1,121.38
Appeal to City Council (Ministerial Items)	\$ 225.00
"Burn-Down" Letter	\$ 67.59
Condition Compliance	\$ 512.05 (Deposit)
Development Review Committee	\$ 230.42
EIR Deposit	\$ 5,120.45
Final Map	\$ 1543.30 (Deposit)
Fire Design Review	\$ 444.46
General Plan Amendment	\$ 3,946.84 (Deposit)
Sign Review	\$ 172.44
Specified Plan Amendment	\$ 2,364.00
Specific Plan Deposit	\$ 3,337.41
Tentative Parcel Map	\$ 3,500.34 (Deposit)
Tentative Subdivision Map	\$ 4,041.06
Per Resulting Lot Tentative Maps	\$ 20.48
Use Permit	\$ 2,889.98 (Deposit)
Variance	\$ 2,317.52 (Deposit)
Zone Change	\$ 3,104.02 (Deposit)
Zoning/General Plan Compliance Letters	\$ 158.73

Source: City of Oroville

Figure 40.1: Building Permit Fees

Building Permit Fees	
Total Valuation	Current Fee
<b>Structural</b>	
\$1.00 to \$500.00	\$24
\$501.00 to \$2,000.00	\$24.00 for the first \$500; plus \$3.00 for each additional \$100 or fraction thereof, to and including \$2,000.00
\$2,001.00 to \$40,000.00	\$69.00 for the first \$2,000.00; plus \$11.00 for each additional \$1,000.00 or fraction thereof, to and including \$40,000.00
\$40,001.00 to \$100,000.00	\$487.00 for the \$40,000.00; plus \$9.00 for each additional \$1,000.00 or fraction thereof, to and including \$100,000.00
\$100,001.00 to \$500,000.00	\$1,027.00 for the first \$100,000.00; plus \$7.00 for each \$1,000.00 or fraction thereof, to and including \$500,000.00
\$500,001.00 to \$1,000,000.00	\$3,827.00 for the first \$500,000.00; plus \$5.00 for each additional \$1,000.00 or fraction thereof, to and including \$1,000,000.00
\$1,000,001.00 to \$5,000,000.00	\$6,327.00 for the first \$1,000,000.00; plus \$3.00 for each \$1,000.00 or fraction thereof, to and including \$5,000,000.00
<b>Other Inspections and Fees</b>	
Inspections outside normal business hours (minimum 2 hours)	\$85.00 per hour*
Re-inspection fees assessed under the provisions of Section 6-1.7; 110.7 of the Oroville City Ordinance 1767.	\$85.00 per hour*
Additional plan review required due to changes, additions, or revisions to plans (minimum 1/2 hour)	\$42.50 per 1/2 hour

For use of outside consultants for plan review and inspections, or both	Actual Cost**
Plan Review: When a plan or other data is required to be submitted for review, the plan review fee for each building, structure, utility, etc. shall be 65% of the building permit fee shown in the Building Permit Fee Table.	
Disabled Access Review: For the review of California Code of Regulation Title 24 requirements for accessibility for the physically disabled, the fee shall be:	\$85.00 per hour*
Energy Conservation Review: For review of the California Code of Regulation Title 24 requirements for energy conservation, the fee shall be equal to 10% of the building permit fee as shown in the Building Permit Fee Table.	
Green Building Standards Review: For review of California Code of Regulations Title 24 requirements for green building standards, the fee shall be equal to 15% of the building permit fee as shown in the Building Permit Fee Table.	
* = or the total hourly cost to the jurisdiction, whichever is greatest. The cost shall include supervision, overhead, equipment, hourly wages and fringe benefits of the employee involved.	
** = Actual cost includes administrative and overhead costs.	

Source: City of Oroville, 2021

**Impact Fees**

Impact fees fund infrastructure improvements to accommodate growth in the community. Impact Fees are listed in “Figure 40.2: Impact Fees.”

Figure 40.2: Impact Fees

DEVELOPMENT IMPACT FEE SUMMARY						
Fee Category	Oroville		Orland		Difference Orland	
	Single Family Residential	Multi-Family Residential	Single Family Residential	Multi-Family Residential	Single Family Residential	Multi-Family Residential
Sewer Impact Fee	\$ 1,794.00	\$ 1,794.00	\$ 2,515.00	\$ 2,465.82	\$ (721.00)	\$ (671.82)
Drainage Impact Fee	\$ 2,572.00	\$ 1,029.00	\$ 1,588.00	\$ 1,344.00	\$ 984.00	\$ (315.00)
Water Impact Fee	\$ -	\$ -	\$ 2,711.00	\$ 2,657.82	\$ (2,711.00)	\$ (2,657.82)
Roads	\$ 961.00	\$ 745.00	\$ 1,736.41	\$ 1,065.91	\$ (775.41)	\$ (320.91)
Parks and Recreation Impact Fee	\$ 3,843.00	\$ 3,095.00	\$ 5,051.59	\$ 4,329.94	\$ (1,208.59)	\$ (1,234.94)
General Government Impact Fee	\$ 1,135.00	\$ 676.00	\$ 5,140.44	\$ 4,406.09	\$ (4,005.44)	\$ (3,730.09)
Police Impact Fee	\$ 1,393.00	\$ 1,122.00	\$ -	\$ -	\$ 1,393.00	\$ 1,122.00
Fire Impact Fee	\$ 804.00	\$ 648.00	\$ -	\$ -	\$ 804.00	\$ 648.00
Library	\$ -	\$ -	\$ 1,356.07	\$ 1,162.35	\$ (1,356.07)	\$ (1,162.35)
<b>Total Per Unit</b>	<b>\$ 12,502.00</b>	<b>\$ 9,109.00</b>	<b>\$ 20,098.51</b>	<b>\$ 17,431.93</b>	<b>\$ (7,596.51)</b>	<b>\$ (8,322.93)</b>
School Fees (Sq Ft)	\$ 4.08	\$ 4.08	\$ 4.08	\$ 4.08	\$ -	\$ -

Source: City of Oroville, Oroville Unified School District, 2021

**Fee Cost Reasonableness**

The impact fees for Oroville were compared to Orland, a town with a population of 8,527 that is also in the northern Central Valley and about 45 miles from Oroville. As shown, total impact fees per unit for single-family and multi-family are much lower in Oroville than for Orland.

As part of the Impact Fee cost reasonableness assessment, land, construction, and fees costs for a typical single-family and multi-family unit were estimated, as shown in “Figure 40.3: Estimated Single-family Development Costs” and “Figure 40.4: Estimated Multi-family Development Costs.” Soft costs such as architecture, engineering, financing, and developer profit are not included. For the single-family construction costs estimate, a 1,500 square-foot home was modeled. The model shows that for a typical single-family home, the total Permit and Impact Fees are estimated at \$21,049, which accounted for 5.5% of the total land and construction costs. For the multi-family construction costs estimate, an apartment complex with 40 units, each 900 square feet in size, was modeled. The model shows that for a typical two-bedroom apartment, the total Permit and Impact Fees are estimated at \$16,885, which accounted for 4.7% of total land and construction costs. The fees in both of these models include School Impact Fees that are charged by the Oroville Unified School District in addition to fees charged by the City of Oroville.

**Figure 40.3: Estimated Single-family Development Costs**

Single Family Home Example		
# of Sq. Ft.	1500	Per Sq Ft Cost
Construction Price Sq. Ft	\$ 200.00	
Lot Cost (10k sq ft)	\$ 37,530.14	\$ 25.02
Construction Cost	\$ 300,000.00	\$ 200.00
Contingency and Overhead (10%)	\$ 30,000.00	\$ 20.00
Permit Fees	\$ 2,427.00	\$ 1.62
Impact Fees	\$ 12,502.00	\$ 8.33
School Fees	\$ 6,120.00	\$ 4.08
<b>Total</b>	<b>\$ 382,459.14</b>	<b>\$ 254.97</b>
<b>Note: This model does not include A&amp;E, Developer Profit and other assorted soft costs.</b>		
<i>Sources: Permit and Impact Fees— City of Oroville. School Fees— Oroville Unified School District.</i>		

Figure 40.4: Estimated Multi-family Development Costs

Multifamily Example			
# of Sq. Ft. per unit	900		
# of Units	40		
Costs		Per Sq Ft Cost	Per Unit Cost
Construction Price Sq. Ft	\$ 260		
Lot Cost (2 acres @ \$244,860 per)	\$ 489,720.00	\$ 13.60	\$ 12,243.00
Construction Cost	\$ 8,684,607.00	\$ 241.24	\$ 217,115.18
Other Costs (\$115,953 per unit)	\$ 4,638,120.00	\$ 128.84	\$ 115,953.00
Permit Fees	\$ 28,433.00	\$ 0.79	\$ 710.83
Impact Fees	\$ 500,080.00	\$ 13.89	\$ 12,502.00
School Fees	\$ 146,880.00	\$ 4.08	\$ 3,672.00
<b>Total</b>	<b>\$ 14,340,960.00</b>	<b>\$ 398.36</b>	<b>\$ 358,524.00</b>
<b>Based on 2020 TCAC-DR Oroville Projects.</b>			
<i>Sources: Permit and Impact fees— City of Oroville. School fees— Oroville Unified School District.</i>			

### Conclusion

Based on an analysis of fee increases, development models, and comparison to other cities, the fees in the City of Oroville do not represent a significant constraint on the construction of new housing. The fees charged by the City of Oroville are lower than other similar size cities in the region. The City of Oroville does not have any ordinances that significantly impact the cost and supply of housing, such as inclusionary zoning or short-term rental ordinances.

## NON-GOVERNMENTAL CONSTRAINTS

---

Non-governmental constraints are largely driven by the market forces of supply and demand that are shaped within the context of government policy at the federal, state, and local levels. By responding to market factors that impact housing availability and affordability, local governments, in cooperation with federal and state agencies, can help improve access to affordable housing for their residents. This section includes an analysis of land prices, construction costs, and residential real estate financing to better understand the challenges and opportunities to addressing housing needs in the City of Oroville.

### Land Prices

Land cost is a fundamental component of the cost of housing. The price of property is impacted by market supply and demand, government land use policies, and the availability of acquisition financing. An analysis of multi-family and single-family residential land prices follows

#### *Multi-family Residential Land*

*“Figure 41: Multifamily Residential Land, City of Oroville, 2020”* shows data from properties for six affordable projects that received tax credit allocations and are currently in development in Oroville. The average price per acre of the six properties is \$244,860 and the average price per square foot is \$5.62.

Figure 41: Multifamily Residential Land, City of Oroville, 2020

Multi-family Land Sales							
Project Name	Address	City	Site Acreage	Site Sq. Ft.	Land Cost	Price per Acre	Land Price Sq Ft
Sierra Heights Phase II	No Address	Oroville	3.76	163,786	\$499,000	\$132,712.77	\$3.05
Oroville Heights Apartments	1409 & 1451 Oro Dam Blvd. W	Oroville	4.96	216,058	\$ 1,190,500	\$240,020.16	\$5.51
Olive Ranch Apartments Phase I	Table Mtn and Grand	Oroville	3.15	137,214	\$ 1,120,000	\$355,555.56	\$8.16
Olive Ranch Apartments Phase II	Table Mtn and Grand	Oroville	2.74	119,354	\$ 1,120,000	\$408,759.12	\$9.38
Mitchell Avenue Senior Apartments	Mitchell Ave between FRB and 5th	Oroville	1.99	86,684	\$330,000	\$165,829.15	\$3.81
Riverbend Family Apartments	205 Table Mountain	Oroville	4.36	189,922	\$725,000	\$166,284.40	\$3.82
					<b>Average</b>	\$244,860.19	\$5.62

Source: City of Oroville 2020 TCAC-DR

### Single-family Residential Land

“Figure 41.1: Single-family Residential Land, City of Oroville, 2021” shows land in Oroville zoned Single-Family Residential that closed sales from October through December, 2021. The price per square foot ranged from \$2.61 to \$5.17 for lots that ranged from 4,792 to 8,886 square feet. The average lot size was 7,289 square feet and the average price was \$3.75 per square foot.

Figure 41.1: Single-family Residential Land, City of Oroville, 2021

Single Family Lot Assumptions					
Address	City	Price	Lot Size	Date Sold	Price per Sq Ft
Yacht Court	Oroville	\$ 35,000	8,276	12/2/21	\$ 4.23
A Street	Oroville	\$ 40,500	7,841	11/16/21	\$ 5.17
2346 C Street	Oroville	\$ 12,500	4,792	11/15/21	\$ 2.61
498 Lodgeview Drive	Oroville	\$ 24,000	7,405	11/5/21	\$ 3.24
Lodgeview Drive	Oroville	\$ 24,000	6,534	10/31/21	\$ 3.67
7 Hawley Trail	Oroville	\$ 32,000	8,886	10/13/21	\$ 3.60
		Average	7,289		\$ 3.75

Source: Realtor.com, 2021

### Construction Costs

Construction costs vary widely depending on the type of structure being built. For instance, the total construction cost of a multi-family structure will cost much more than a single-family home, though the cost of each unit in the multi-family structure will generally cost less due to the economies of scale. The development models shown in Figures 41 and 41.1 demonstrate that multi-family construction is generally more expensive per square foot but usually has lower costs per unit due to smaller unit sizes. Multifamily and single-family construction costs in Butte

County are comparable to other similar size counties in the Central Valley, and generally lower than in the Sacramento Metropolitan Area.

An analysis of total development costs for six affordable tax credit projects in Oroville currently in development was conducted and listed in “*Figure 41.2: Multi-family Construction Costs, City of Oroville, 2021.*” Total construction costs for these projects averaged \$239,548 per unit and \$260 per square foot. If funding sources require payment of State Prevailing Wages, construction costs are generally about 15%-20% higher. Senior and studio subsidized apartment complexes generally cost less per unit and more per square foot. Subsidized apartments are generally more expensive to build than market rate apartments because costs, such as developer overhead and profit, financing, and reserves, must be front-loaded into the development budget instead of future year operating budgets. This is because publicly subsidized project rents are restricted to levels affordable to low-incomes. Operating income largely covers annual expenses only, with narrow profit margins over the operating period. Furthermore, rent restriction covenants limit price appreciation, as subsidized projects cannot be resold at market prices until 30 to 55 years after they are built.

Figure 41.2: Multi-family Construction Costs, City of Oroville, 2021

Project Name	Address	Total Development Cost (TDC)*	Land Cost	Construction Cost	All Other Costs	Construction Cost (Sq. Ft)	Construction Cost (Unit)
Sierra Heights Phase II		\$16,414,489	\$499,000	\$9,056,000	\$6,859,489	\$210.00	\$192,680.85
Oroville Heights Apartments	1409&1451 Oro Dam Blvd. W	\$23,722,012	\$1,190,500	\$14,161,000	\$8,370,512	\$197.00	\$217,861.54
Olive Ranch Apartments Phase I	Table Mtn and Grand	\$30,650,580	\$1,120,000	\$21,261,340	\$8,269,240	\$281.00	\$265,766.75
Olive Ranch Apartments Phase II	Table Mtn and Grand	\$30,331,815	\$1,120,000	\$20,998,000	\$8,213,815	\$281.00	\$262,475.00
Mitchell Avenue Senior Apartments	Mitchell Ave between FRB and 5th	\$12,323,761	\$330,000	\$7,663,161	\$4,330,600	\$304.00	\$218,947.46
Riverbend Family Apartments	205 Table Mountain	\$27,924,953	\$725,000	\$19,848,570	\$7,351,383	\$287.00	\$279,557.32
	Average	\$23,561,268	\$830,750	\$15,498,012	\$7,232,507	\$260.00	\$239,548.00

Source: City of Oroville and California Tax Credit Allocation Committee, 2021

Construction costs have increased significantly over the past five years. These increases have been driven by increases in labor and material costs. The Turner Center for Housing Innovation at UC Berkeley conducted an analysis of multi-family construction costs across California in 2020. In their report, they pointed out that construction costs increased by 24% statewide between 2009 and 2018. For the period of 2014 and 2018, the increase was 44% percent. The average per square foot hard cost was \$177 in 2009, and in 2018 it was \$222.

According to the Turner Center report, wages for the Construction and Extraction Occupations category saw an increase of 28.7% between 2006 and 2018. Cement Masons and Concrete Finishers saw the most significant increase in wages at 32.5%. Some of these wage increases were attributed to higher levels of overhead, profit, and contingency by general contractors and subcontractors to mitigate the risk and costs associated with a restricted workforce, and to ensure that they retain workers in a competitive labor shortage environment. (Source: *The Hard Costs of Construction: Recent Trends in Labor and Materials Costs for Apartment Buildings in California*. The Turner Center for Housing Innovation, UC Berkeley, March 2020.)

Construction costs have been further accelerated by large increases in the cost of materials. Between 2010 and 2018, the cost of concrete increased by 28%, finishes and gypsum increased 65%, and lumber increased 110%. Metals was the only material that decreased over that time period, with a 39% drop. The COVID-19 pandemic has contributed to further cost increases. In some areas, the cost of lumber tripled as supplies became constrained due to sawmills shutdowns.

The increase in construction costs can be attributed to many factors, but is most significantly due to large increases in materials costs and a restricted workforce. It is not clear if these factors will continue during the next housing element period, but if they do, it could significantly impact not only the number of units that are built, but also their affordability as well.

### **Financing Availability**

Over the past eight years, financing for residential real estate has gradually recovered from the recession of 2008. Interest rates over the past three years have remained at historically low levels, influenced by a federal funds rate near zero percent and federal investment in securities to shore up the economy during the coronavirus pandemic. At the same time, the risky lending practices that precipitated the housing bubble and subsequent recession have been reformed and defaults have declined significantly. After some uncertainty in 2020, equity and debt were much more aggressively employed in 2021 and are expected to continue to be readily available for a variety of residential real estate investments over the next few years.

### ***Multifamily Rental Financing***

Multifamily lending is forecast to reach about \$421 billion in 2022, up from the record \$409 billion estimated for 2021, which was a 13% increase from 2020 according to the Mortgage Bankers Association. Fannie Mae and Freddie Mac plan to increase their levels of multifamily investment in 2022 by increasing purchase caps, broadening the scope of eligible borrowers and projects, and expanding their products with flexible terms and low interest rates. (Source: *Why a Lending Bounty Awaits Multifamily Borrowers*. Multi-Housing News, November 30, 2021).

Most multifamily loan interest rates are currently tied to the 30-day LIBOR or U.S. Treasury 10-Year Note. The 30-day LIBOR has been stable between December 2020 and 2021, varying between 0.07% to 0.16%, with a rate as of December 2021 at 0.10%. LIBOR is expected to be phased out as a benchmark lending index over the next couple years, and will be replaced by another index that broadly measures bank borrowing costs. The 10-Year Treasury Note has risen from about 0.9% in December 2020 to about 1.5% in December 2021 (Wall Street Journal, December 10, 2021). Over the next year, interest rates on multi-family debt should continue to be in the 2%-4% range for tax-exempt bond funded construction loans and the 3%-5% for permanent loans and market rate commercial construction loans (Commercial Real Estate Finance Company of America, December 2021). Fannie Mae's current multifamily loan interest rates are roughly 3.6%-4.0% for a fixed 30-year amortized term (Fannie Mae, December 2021). Current FHA 223(f) multifamily loan interest rates are generally 2.65%-3.65% for a fixed 35-year amortization term (Federal Housing Administration, December 2021). Most affordable housing in California is financed by tax-exempt bonds that are allocated to projects by the California Debt Limit Allocation Committee (CDLAC).

Freddie Mac tracks an Apartment Investment Market Index (AIMI) to measure the relative value of investing in multi-family properties in select major metropolitan areas. From the second quarter of 2020 to the second quarter of 2021, the AIMI rose from 129.2.3 to 132.6. Freddie Mac stated that the increase in the index over the past year was the result of growth in net operating income for apartment complexes and lower mortgage rates, which offset strong growth in property prices (Freddie Mac Apartment Investment Index, 2<sup>nd</sup> Quarter, 2021). Equity for market rate multifamily housing is usually invested by Real Estate Investment Trusts (REITs). Publicly traded REITs have performed well over the last 10 years, with average annual return of 11.29% between October 2011 and October 2021 (Nareit Industry Fact Sheet, October 2021).

Equity for affordable housing is usually invested by banks and corporations that receive tax credits and deductions in return for their investment. Tax credit investors negotiate an equity price per dollar of tax credit received for each affordable housing project. Equity pricing for Federal Low Income Housing Tax Credits (LIHTC) in California has been gradually rising after a drop in investor interest in 2020. While LIHTC pricing varies greatly depending on project particulars, the partners involved, and location, national pricing averaged about \$0.90 per tax credit dollar in the second half of 2021 (CohnReznick Housing Tax Credit Monitor, November

2021 and Novogradac LIHTC Equity Pricing Trends, August 2021). While projects in major California metropolitan markets such as Los Angeles and the Bay Area tend to draw significantly higher pricing than the nationwide average, projects in rural areas of California have historically seen pricing closer to the nationwide average.

Federal funding for affordable multifamily housing is projected to expand over the next few years based on the recently passed American Rescue Plan and HUD budgets, proposed federal budgets for FY 2022, and the housing components of the proposed Build Back Better Act. These initiatives will significantly bolster resources for federal tax credits, entitlement grants for housing production, rental assistance, and homeless services. At the State level, budget surpluses and the Governor's commitment to addressing California's housing needs figures to continue financial support for housing programs.

At the beginning of the new Housing Element period, the Chico and the surrounding area will see increased investment in subsidized multifamily rental financing through the Community Development Block Grant- Disaster Recovery (CDBG-DR) program. The purpose of this program is to use federal funds made available through the Presidential Disaster Declaration associated with the Camp Fire to replace destroyed units. Butte County has received an allocation of \$61 million dollars, with \$6.6 million planned for three new construction affordable multifamily projects in Oroville.

### ***Homeownership Financing***

The full-year average interest rate on a 30-year fixed rate mortgage was 3.0% in 2021 (Freddie Mac Market Rates Survey, December 9, 2021). After large monthly purchases of treasuries and mortgage securities over the past two years, the Federal Reserve has indicated that it is ready to start diminishing its purchases of treasuries and mortgage securities through 2022. At the same time, it is expected that the Federal Reserve will slightly increase the Federal Funds Rate over 2022. These factors are expected to push mortgage interest rates modestly upward between 0.3% and 0.5% on a 30-year fixed rate loan by the end of 2022 (*Kiplinger's Interest Rates Forecast*. Kiplinger, September 2021.) Freddie Mac projects that refinance activity will soften towards the end of 2022 as interest rates rise, and total mortgage originations will decline from \$4.5 trillion in 2021 to \$3.1 trillion in 2022 (*Quarterly Forecast*. Freddie Mac, October 15, 2021).

## Natural Disaster Impacts

### *COVID-19*

On March 13, 2020, the President declared the ongoing Coronavirus Disease 2019 (COVID-19) pandemic of sufficient severity and magnitude to warrant an emergency declaration for all states, tribes, territories, and the District of Columbia pursuant to section 501 (b) of the Robert T. Stafford Disaster Relief and Emergency Assistance Act, 42 U.S.C. 5121-5207 (the “Stafford Act”). This declaration shut down “non-essential” businesses such as bars, restaurants and most retail stores. Essential businesses included hardware stores, supermarkets, and other retailers that sold food or medical supplies. Housing construction was considered an essential business, however, COVID still had a severe impact in that sector. Construction sites had to deal with shutdowns due to COVID outbreaks. Many factories supplying building materials experienced shutdowns or reduced staffing. This led to severely constrained supply inventories. Construction projects were delayed due to materials shortages. These delays resulted in fewer units being built to meet the high demand for housing. This contributed to higher home prices and rents. With the increase in vaccinations and the decline in COVID-19 cases, housing construction began to recover in the second half of 2021.

### *Camp Fire*

On November 18, 2018, a faulty electrical line sparked the deadliest and most destructive wildfire in the history of the State of California in the foothills of Butte County. When the fire was finally fully contained on November 25<sup>th</sup>, 2018, it had killed 85 people, burned almost 240 square miles, and destroyed 18,000 structures, most of which were dwelling units. The towns of Paradise and Concow were almost completely destroyed, and 56,000 people were evacuated with 20,000 of them relocating permanently.

A study was conducted by Economic and Planning Systems that was released in January of 2021 that examined the impact of the Camp Fire in Butte, Glenn and Tehama counties. According to the study, most of the residents relocating from Paradise, Magalia, and Concow initially moved to Chico, with a much smaller portion also relocating to Oroville and Orland. The City of Oroville grew by 2,707 persons between 2016 and 2019 and decreased of 2,931 persons from 2019 to 2021. The population of Butte County as a whole decreased dramatically by 23,429 (10.4%) between 2018 and 2021.

### ***Local Response to Non-governmental Constraints***

While the City of Oroville cannot directly impact non-governmental constraints, the City will address these constraints by working toward goals that reduce governmental constraints as outlined below.

### ***City Actions that Address Non-governmental Constraints***

The following actions in the Chapter 3 Housing Program address non-governmental constraints that are described above.

#### **Land Prices**

*Program 2.1.8* addresses high land prices by facilitating ADU development on existing land developed with single-family residences.

#### **Construction Costs**

*Program 2.1.2* will defer City development impact fee payments through a deed of trust until a certificate of occupancy is issued for affordable projects utilizing the Density Bonus Program. This will reduce construction financing costs for these projects. *Program 2.1.4* commits the City to periodically survey permit and impact fees of other cities in Butte County to ensure that City fees are reasonably related to the cost of services provided. This will help keep permit and impact fees in check, which are a significant portion of housing development costs.

*Programs 4.1.2, 4.1.3, and 4.3.2* address high construction costs by implementing strategies to preserve, rehabilitate, and/or convert existing structures to rent-restricted affordable housing with long-term rent restrictions. Preservation and rehabilitation is generally much less expensive than new construction.

#### **Financing Availability**

*Program 3.2.1* directs the City to partner with developers to leverage federal, state, and private sources to meet the City's housing goals.

*Program 6.2.1* directs the City to collaborate with NCIHA to provide Permanent Local Housing Allocation (PLHA) funds to affordable housing in the form of grants or deferred payment loans.

## Natural Disaster Impacts

*Program 6.2.2* directs the City to address the impacts of the 2018 Camp Fire and 2020 North Complex Fire by analyzing the permitting and development process to provide expedited processing times for mixed-income, high density, infill, and multi-family housing development.

## AFFIRMATIVELY FURTHERING FAIR HOUSING: IDENTIFICATION AND PRIORITIZATION OF CONTRIBUTING FACTORS

---

With the passage of AB 686, the Housing Element now includes a section on affirmatively furthering fair housing called “identification of contributing factors.” A fair housing contributing factor is one that creates, contributes to, perpetuates, or increases the severity of one or more fair housing issues, focusing on the topics in the assessment of fair housing: segregation, racially and ethnically concentrated areas of poverty, disparities in access to opportunity, and disproportionate housing needs. (*California State Department of Housing and Community Development, Affirmatively Furthering Fair Housing, 2021*). As recommended by State HCD, “*Figure 42: Affirmatively Furthering Fair Housing: Identification of Contributing Factors*” identifies fair housing issues, contributing factors, meaningful City action, and the priority of the issues from high to low.

Figure 42: Affirmatively Furthering Fair Housing: Identification of Contributing Factors

Priority (high, medium, low)	Fair Housing Issue	Contributing Factors	Meaningful City Action
<p><b>High</b></p>	<p>Census Tract 30.01 has been prioritized as an area for redevelopment because 30-40% of the population is living with a disability (which is the highest in the County), 60-80% of homeowners are overpaying, 60-80% of renters are overpaying, the area median income is less than \$30,000, 30-40% of the population is living in poverty, it is an area of high segregation and poverty, and the level of overcrowding is double the State’s average at 15-20% of households.</p> <p>In addition, Census Tracts 25, 28, 30.01, 30.02, and 37 are areas of high segregation and poverty and disproportionately experience more housing issues and burdens than other areas in the City.</p>	<p>Lack of private investments in specific neighborhoods. Possibility of patterns or trends of segregation based on income, race/ethnicity, household characteristics, and/or disability.</p> <p>Displacement of residents due to disaster and resulting economic pressures, as well as housing shortages and lack of affordability persisting after disaster may have exacerbated poor housing issues in the entire City. In addition, there is a lack of mixed-density and mixed-use development.</p>	<ol style="list-style-type: none"> <li>1. City to prioritize future rehabilitation, community beautification, infrastructure improvements or other investment efforts in Census Tract 30.01, when deemed financially feasible. To the extent possible, City to focus redevelopment efforts in Census Tracts 25, 28, 30.02 and 37 as well.</li> <li>2. City to consider donating acquired land or foreclosures for redevelopment in Census Tracts 25, 28, 30.01, 30.02 and 37 to nonprofits or work with nonprofits to develop housing that fits the needs of residents.</li> <li>3. Incentivize mixed income and multi-family development in Census Tracts 27 and 31, which are areas that experience more</li> </ol>

			<p>affluence, to encourage patterns of integration.</p> <ol style="list-style-type: none"> <li>4. Identify areas for future affordable housing development outside areas of High Segregation and Poverty, which include Census Tract 27 and 31.</li> <li>5. Recruit residents from areas of high segregation and poverty to serve on boards, committees, task forces, and other local government decision making bodies</li> <li>6. Need for improved permitting and development processes, such as flexible allowances, and incentives for infill development</li> </ol>
<p><b>High</b></p>	<p>The household income of half of the population is less than \$35,000, which means more than half the population cannot afford the average-priced one-bedroom unit in Butte County. Fires in the region, including the North Complex Fire and the Camp Fire have impacted housing availability in the region and</p>	<p>There is a shortage of permanent supportive housing and multi-family rental housing. Need for one-bedroom/studio units, accessible units, and three- bedroom units.</p>	<ol style="list-style-type: none"> <li>1. Involve the community in future City planning processes, with an emphasis on residents residing in Census Tracts 25, 28, 30.01, 30.02 and 37.</li> <li>2. Oroville Blight study</li> <li>3. Fair Housing Workshops and Education</li> </ol>

	<p>driven up housing costs. The City will focus its efforts on providing housing for at-risk, special populations identified in the Assessment of Fair Housing, which include seniors, people with disabilities, people experiencing mental health conditions, and female-headed households with no partner present.</p>	<p>Displacement of residents due to economic pressures. Lack of community revitalization strategies</p>	<p>4. Apply for CDBG public services grant</p>
<p><b>Medium</b></p>	<p>Renters are becoming significantly more likely to experience 1 in 4 Housing Problems or 1 in 4 Severe Housing Problems in comparison to owners. An estimated 70% of households that have 1 in 4 Housing Problems or 1 in 4 Severe Housing Problems are renter households. Furthermore, there is a significantly large number of renter-occupied housing units.</p>	<p>Substandard housing conditions.</p>	<ol style="list-style-type: none"> <li>1. Work with the State government to consider using CDBG funds for rehabilitation of both renter households and owner-occupied households.</li> <li>2. Develop a low-income home rehabilitation program in which the City using PLHA funds.</li> <li>3. Work with Community Housing Improvement Program (CHIP), Habitat for Humanity, or other local nonprofit developers to identify areas for development/opportunities for homeownership.</li> </ol>

			<p>4. Work to improve outreach/accessibility to local utility assistance programs in the region. Contract with Southside Oroville Community Center for residential services.</p>
<p><b>Medium</b></p>	<p>According to qualitative data from interviews with key stakeholders, protected classes, including low-income residents, single mothers, persons with physical disabilities, persons with mental health conditions, and senior residents face barriers acquiring housing due to poor credit, poor rental histories, income requirements, and felony records. An overwhelming majority of renters in the City are overpaying and these residents could benefit from robust services and programs to complement housing.</p>	<p>Possibility of patterns or trends of segregation based on income, race/ethnicity, household characteristics, and/or disability. Residents may be unaware of programs they are eligible for or have trouble applying for utility payment assistance and housing rehabilitation assistance. Lack of assistive services to complement housing.</p>	<ol style="list-style-type: none"> <li>1. Partner with school districts, Southside Oroville Community Center, Legal Services of California, and Disability Action Center.</li> <li>2. Integrate City and County services to better serve residents and determine eligibility for programs. Single point-of-contact for referrals/answering questions.</li> </ol>

<p><b>Low</b></p>	<p>An average of 20-30% of the population has a disability, which is significantly higher than other areas of Butte County.</p>	<p>Areas within the City fall in “low resource” or “high segregation and poverty” categories, as defined by HCD’s opportunity maps. Low-income residents are much more likely to have a disability.</p>	<ol style="list-style-type: none"> <li>1. Disability accommodations in regional planning/City’s general plan.</li> <li>2. Develop an accessibility improvements fund.</li> </ol>
<p><b>Low</b></p>	<p>Oroville has the most fair housing inquiries in Butte County.</p>	<p>Limited City capacity for fair housing enforcement and outreach activities.</p>	<ol style="list-style-type: none"> <li>1. Develop and fund a formal process for receiving, reviewing, and responding to fair housing complaints in collaboration with Legal Services of Northern California</li> <li>2. Meet with North Valley Property Owners Association (NVPOA) and Legal Services of Northern California (LSNC) at least once per year to coordinate information, referrals, and outreach to residents. Promote existing fair housing workshops to both residents and landlords. This may include creating informational materials to distribute at City Hall, posting on the City’s website, and Facebook page, and sending an “email blast”</li> </ol>

			to the City's stakeholder contact list.
--	--	--	---

APPENDIX A

Review of Previous Housing Element Programs: 2014- 2022						
Goal	Action Number	Action Statement/Intended Objective	Timeframe in Housing Element	Accomplishments/Analysis	Continue, Modify or Delete?	Adjustment to Meet New State Laws
<b>H.1: Expand housing opportunities and accessibility</b>						
	1.1.1	Provide homebuyer and first-time homebuyer assistance up to \$100,000 or 45% of the purchase price of the home, whichever is less (max purchase price is \$200k/updated to HUD limits). Goal to assist 5 units per year.	Annually	<b>Objective met.</b> The program has been well-utilized and the City has applied for and been rewarded 2019 HOME funds, CDBG NOFA, and CDBG homebuyer funds totalling 3 million to continue the program.	Continue	
	1.2.1	Cooperate with Butte County Continuum of Care to reduce the number of homeless individuals in the area	Ongoing	<b>Objective met.</b> City Council member meets with the Coalition on a regular basis to further COC objectives.	Continue	

	1.2.2	Ensure that zoning for emergency shelters, transitional and supportive housing, and SROs is consistent with State law. In addition, provide assistance with grant applications for the development of new facilities to serve the homeless.	2014	<b>Objective not met.</b> The City has been notified of changes to State legislation (AB 101) and will modify this program to allow low barrier navigation centers where residential uses are permitted.	Modify	The City will modify this program to meet the requirements set forth by AB 101 for Low Barrier Navigation Centers.
	1.2.3	Maintain and publicize a comprehensive listing of housing developments that serve lower-income households, persons with disabilities, and other special needs populations.	Annually	<b>Objective met.</b> The latest update is complete and posted on the City's website.	Continue	
	1.3.1	In accordance with SB 520, the city will allow for the approval of exceptions to land use regulations to provide reasonable accomodation for persons with disabilities.	Ongoing	<b>Objective exceeded.</b> City Council's Ordinance No. 1804 created an administrative mechanism for a disabled person to file a request for reasonable accommodation to make specific housing available to one or more individuals	Continue with modifications	

				protected under the Fair Housing Laws.		
	1.4.1	Continue to ensure that local zoning, development standards, and permit processing do not conflict with Health and Safety Code.	2014	<b>Objective met.</b> City Council's Ordinance No. 1804 included provisions to allow farmworker and migrant housing.	Delete	
<b>H.2: Remove constraints to housing</b>						
	2.1.1	Ensure City's review and approval do not constrain residential development, including multi-family housing and housing affordable to low-to-moderate income households.	Annually	<b>Objective met.</b> The City offers concurrent processing to streamline development and the zoning ordinance provides incentives for low income housing including fast-track processing and density bonuses. The City also offers pre-application / development review meetings to help minimize processing times and give developers information. In 2020, the City approved deferring development impact fees by deed of trust until occupancy is issued.	Continue	

	2.1.2	Track HE implementation progress as part of annual report submitted to HCD	Annually	<b>Objective met.</b> The City has submitted an annual progress report on the Housing Element and is in compliance with State law. The City will modify this program to include No Net Loss provisions.	Modify/ Establish new program	The City will be implementing a formal Unit Production Evaluation (Per Government Code 65863 "No Net Loss") with a regular update to the Housing Element Site Inventory.
	2.1.3	Survey the development application, plan check, and inspection fees, impact fees, and utility connection fees of other cities in Butte County to ensure these are reasonable cost.	Every other year beginning in 2015	<b>Objective met.</b> Latest update was completed in 2020. An additional update is in process. In the last update, the city approved a fee deferral program for subdivisions of all income types.	Continue	
<b>Goal H.3: Facilitate the development of new housing</b>						
	3.1.1	Update City's GIS system to track development and maintain a list of vacant residential lots.	By request	<b>Objective met.</b> The latest update was complete and posted on the City's website	Continue	

	3.1.2	Implement the Corridor Opportunity Site overlay through the use of incentives and flexibility in development. Incentivize development of 50 moderate-income units and 20 low-income units within the Corridor Opportunity Site by 2022.	Ongoing	<b>Objective Met.</b> In 2015, the City updated zoning code and maps to coincide with the General Plan land use designations. City's MXC and MXN mixed use zones now permit multi-family, high-density residential development.	Delete	
	3.1.3	Coordinate an annual workshop with the Oroville Economic Development Corporation to identify housing needs of employees	Annually	<b>Objective not met.</b> The City is no longer coordinating this workshop. The Oroville Economic Development Coordination is quiescent and the City will modify this program.	Modify	
	3.2.1	Work with developers to identify sources of funding and provide technical assistance to seek funding for new affordable multi-family housing, including units for large family households, extremely low income, and	Annually	<b>Objective exceeded.</b> The City was awarded HOME funding for the development of the Sierra Heights Project for seniors, in which Phase 1 is complete (42 units for ELI seniors) and Phase 2 will begin. The City has donated land (12 townhomes to veterans under 80% AMI)	Continue	

		persons with developmental disabilities. Pursue tax-exempt mortgage bonds, HCD's multifamily housing program, and LIHTC		and is working with Veteran Housing Development Corporation to develop and design a supportive housing project (60% and below AMI). The City has also worked with developers to apply for State tax credits for the development of 5 affordable multi-family projects (312 LI and ELI units). The City also assisted in the development of a supportive housing project on Nelson road.		
<b>Goal H.4: Preserve, rehabilitate, and enhance existing neighborhood</b>						
	4.1.1	Seek grants to augment current code enforcement activities to supplement the graffiti removal program, fund neighborhood cleanup fairs, and general code enforcement and community beautification efforts. Utilize groups (i.e. Neighborhood watch) to supplement activities. Where	2017	<b>Objective exceeded.</b> Code enforcement activities are currently being funded with 2017 CDBG funds, which expire in July 2022. The City has assembled a task force of law enforcement, code enforcement, and staff from Parks and Trees to identify code issues and housing complaints. The City was awarded CalOES funds due to disaster impact. There are currently 5 code enforcement officers, and	Continue	

		possible, link to available funding for improvements and correction of violations.		the City intends to add 2-4 more officers.		
	4.2.1	Install and upgrade public service facilities (streets, curb, gutter, drainage, and utilities) to increase private market investment in declining, deteriorating, and infrastructure deficient neighborhoods.	Ongoing	<b>Objective not met.</b> The City is in the process of evaluating public facilities on condition, demands, and future needs. Impact fees are used to make the infrastructure investments to support growth, infill, and desification. The City is seeking funding. However, the City developed a Capital Improvement program that will be implemented annually with roadway, sewer, and drainage infrastructure improvements..	Continue	Modified to more fully address the requirements of AB 683 "Affirmative Furthering Fair Housing"
	4.3.1	Purchase abandoned homes and provide rehab assistance.	Annually	<b>Objective not met.</b> The City does not have funding. The City is transferring foreclosed housing to the Veterans Housing Development Corporation to sell to extremely low income and low income veterans. The last 2 homes	Continue	Modified to more fully address the requirements of AB 683 "Affirmative Furthering Fair Housing"

				were sold at market-value and the City is not currently doing rehabilitation. The City has applied for LEAP/PLHA funds to continue this program. The City is currently conducting a Blight study in South Oroville and will use the information retrieved from the survey to guide future redevelopment efforts.		
	4.3.2	Continue Owner Occupied Single Family Rehabilitation Program, funding 5 units over the next planning period.	ongoing	<b>Objective not fully met.</b> The City assisted in 1 rehabilitation in 2016, but cannot fund more than 3 projects. The City received \$750,000 for rehabilitation from CDBG, but has not been able to secure a contractor for the project and needs more funding to continue this program.	Continue	Modified to more fully address the requirements of AB 683 "Affirmative Furthering Fair Housing"
	4.3.3	Provide funding assistance for rehab of multi-family units.	ongoing	<b>Objective not met.</b> The City does not have the funding to continue this program.	Delete	

	4.4.1	Continue partnership with California Housing Partnership Corporation to identify at-risk units and apply for state and federal funding for preservation i.e. HOME, CDBG, MHP. Maintain relationships with developers and on-site managers.	Ongoing	<b>Objective not met.</b> The City does not have the funding to continue this program.	Modify/ Establish new program	
<b>Goal H.5: Promote fair housing</b>						
	5.1.1	Require that all recipients of locally-administered housing funds acknowledge their responsibilities under the fair housing law and affirm commitment. Coordinate and host workshops to educate property owners, managers, real estate professionals, and tenants about fair housing laws, discrimination, and protections. Publicize	Ongoing	<b>Objective not fully met.</b> City staff has attended fair housing training. The City would like to coordinate workshops and education and increase promotion. The last workshop was coordinated in 2016. The City regularly posts flyers regarding fair housing information.	Modify	Modified to more fully address the requirements of AB 683 "Affirmative Furthering Fair Housing"

		fair housing and dispute resolution information through flyers/brochures at city Hall, the library, community centers, senior centers, local service offices, real estate offices, mortgage offices, management offices, and on the City's website.				
	5.1.2	Engage in a public noticing campaign to inform persons with disabilities of their ability to locate senior citizen independent living facilities.	Annually	<b>Objective met.</b> The City currently has information materials for available senior housing available at City Hall. The City works with Butte County Housing Authority, Community Action Agency, and other special interest groups. The City administered a housing needs survey to seniors.	Modify	Modified to more fully address the requirements of AB 683 "Affirmative Furthering Fair Housing"
<b>Goal H.6: Encourage energy conservation</b>						
	6.1.1	City to require all new residential development to comply with energy conservation requirements of Title	ongoing	<b>Objective met.</b> The City's Building Department last updated requirements in 2019.	Delete	

		24 of California Administrative code.				
	6.1.2	Publicize utility incentives for energy conservation through flyers and on the City's website.	Annually	<b>Objective met.</b> In 2016, the City approved to include properties within the City of Oroville in three different Property Assessed Clean Energy (PACE) programs. 1)Ygrene Works, 2) HERO, and 3) Open PACE and updated this information on their website.	Modify	

APPENDIX B

Table A: Housing Element Sites Inventory

Jurisdiction Name	Site Address/Intersection	5 Digit ZIP Code	Assessor Parcel Number	Consolidated Sites	General Plan Designation (Current)	Zoning Designation (Current)	Minimum Density Allowed	Max Density Allowed (units/acre)	Parcel Size (Acres)	Existing Use/Vacancy	Infrastructure	Publicly-Owned	Site Status	Identified in Last/Last Two Planning Cycle(s)	Lower Income Capacity	Moderate Income Capacity	Above Moderate Income Capacity	Total Capacity
OROVILLE	Veatch Street	95965	035-250-054-000	A	MU	MXC	10	30	2.72	City Corp Yard	YES - Current	YES - City-Owned	Pending Project	Not Used in Prior Housing Element	48	0	0	48
OROVILLE	Veatch Street	95965	035-250-002-000	A	MHD R	R-3	14	20	3.96	City Corp Yard	YES - Current	YES - City-Owned	Pending Project	Not Used in Prior Housing Element	70	0	0	70
OROVILLE	Mitchell Avenue	95965	035-240-100-000		MU	MXC	10	30	1.55	Vacant	YES - Current	NO - Privately-Owned	Pending Project	Not Used in Prior Housing Element	27	0	0	27
OROVILLE	Butte Ave and 5th Street	95965	031-100-008-000	B	MDR	R-2	6	14	9.5	Vacant	YES - Current	NO - Privately-Owned		Not Used in Prior Housing Element	0	57	0	57
OROVILLE	Butte Ave and 5th Street	95965	031-100-001-000	B	MDR	R-2	6	14	3.49	Vacant	YES - Current	NO - Privately-Owned		Not Used in Prior Housing Element	0	20	0	20
OROVILLE	Maude Ave	95965	031-100-024-000	C	RR	RR-20	0.2	3	8.87	Vacant	YES - Current	NO - Privately-Owned		Not Used in Prior Housing Element	0	0	26	26

<b>OROVILLE</b>	Maude Ave	95965	031-100-025-000	C	RR	RR-20	0.2	3	8.85	Vacant	YES - Current	NO - Private ly-Owned		Not Used in Prior Housing Element	0	0	26	26
<b>OROVILLE</b>	Nelson Ave	95965	031-020-043-000		MLD R	R-1	3	6	56.45	Vacant	YES - Current	NO - Private ly-Owned		Not Used in Prior Housing Element	0	0	338	338
<b>OROVILLE</b>	Lincoln Street	95965	035-040-056-000		MU	MXC	10	30	6.5	Vacant	YES - Current	NO - Private ly-Owned	Pending Project	Not Used in Prior Housing Element	117	0	0	117

APPENDIX C



**City of Oroville 2022 Housing Element Update**  
**Community Meeting #1: Housing Needs & Issues**  
**Live Poll Results**  
**October 20, 2021**

Community members responded to trilingual polls in English, Spanish, and Hmong that were launched live during the meeting. Both the polls and community members' aggregated responses are provided below.

**Poll 1**

Have you participated in previous Housing Elements? / ¿Ha participado en Elementos de Vivienda anteriores? / Koj puas tau tuaj koom hais txog Tsevnyob yav tas los?

- a. Yes / Sí / Tau
- b. No / No / Tsis tau
- c. Unsure / No estoy seguro / Tsis paub

Chart 1: Have you participated in previous Housing Elements?  
(n=10, single choice)

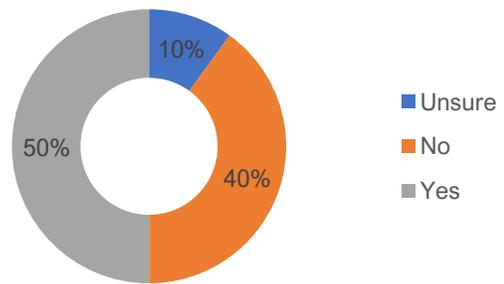

**Poll 2**

Which housing issues are you most interested in? Please select all that apply. / ¿En que problemas de vivienda está usted más interesado? Por favor seleccione todas las respuestas que correspondan. / Hom tsev nyob abtsi ua koj txausiab tshaj? Xaiv tag nrho cov raug rau koj.

- Accessible housing for people with disabilities / Vivienda accesible para personas con discapacidades / Vajtsev rau cov neeg semcev
- Accessory dwelling units (ADUs) / Unidades de Vivienda Accesorias (ADUs, siglas en Inglés) / Tsev nyob (ADUs)
- Affordable housing / Viviendas asequibles / Cov tsev nyob ua them taus pheejyig
- Market-rate housing / Viviendas a precio de mercado / Tsev nyob raws tus nqi kiabkhws
- Multifamily housing / Viviendas multifamiliares / Ntau ntau lub tsev rau tsevneeg nyob sibpuab
- Permanent supportive housing / Viviendas de apoyo permanente / Cov tsev nyob ua muaj kev pab mus li
- Single-family housing / Viviendas unifamiliares / Tsev kheej ib lub ib lub
- Other / Otro / Lwmyam

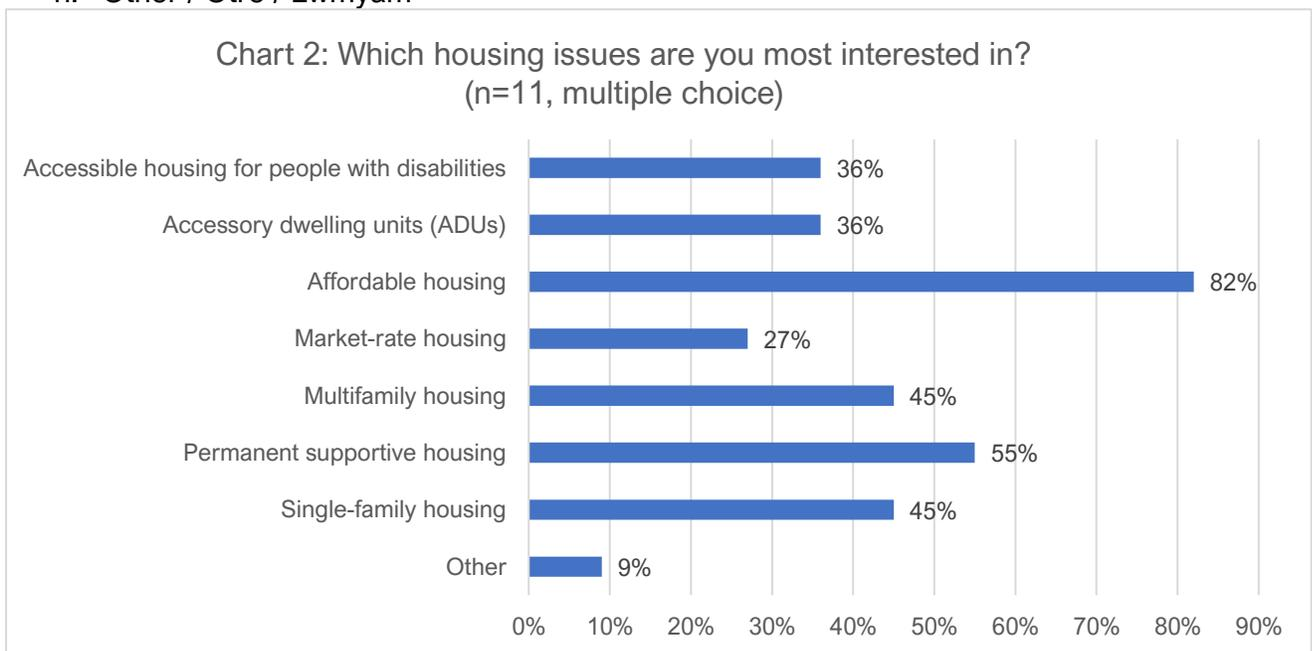

### **Poll 3**

Where would you like the City of Oroville to concentrate its efforts? / ¿Dónde le gustaría que la Ciudad de Oroville concentre sus esfuerzos? / Koj xav kom lub Nroog Oroville ua abtsi?

- First time home buyer programs / Programas para compradores de vivienda por primera vez / Muaj kev pab rau cov thawj zaug yuav tsev
- Housing for people experiencing homelessness / Viviendas para personas que no tienen hogar / Muaj vajtsev pab rau cov neeg ua tau poob mus ua neeg tsis muaj vajtsev nyob lawm
- Infill development / Desarrollo de rellenos/ Tsim kho
- Multifamily affordable housing / Vivienda multifamiliar asequible / Cov tsev ntau ntau tsevneeg nyob uake pheejyig them tau

- e. Multifamily market rate housing / Vivienda multifamiliar a precio de mercado / Cov tsev ntau ntau tsevneeg nyob uake tus nqi kiabkhw
- f. Rehabilitation and preservation of existing housing / Rehabilitación y preservación de viviendas existentes / Vajtsev rau cov neeg los thum kev mob nkeeg yeeb tshuaj
- g. Single-family affordable housing / Viviendas unifamiliares asequibles / Tsev kheej them tau pheejyig
- h. Single-family market rate housing / Viviendas unifamiliares a precio de mercado / Tsev kheej tus nqi kiabkhw
- i. Other / Otro / Lwmyam

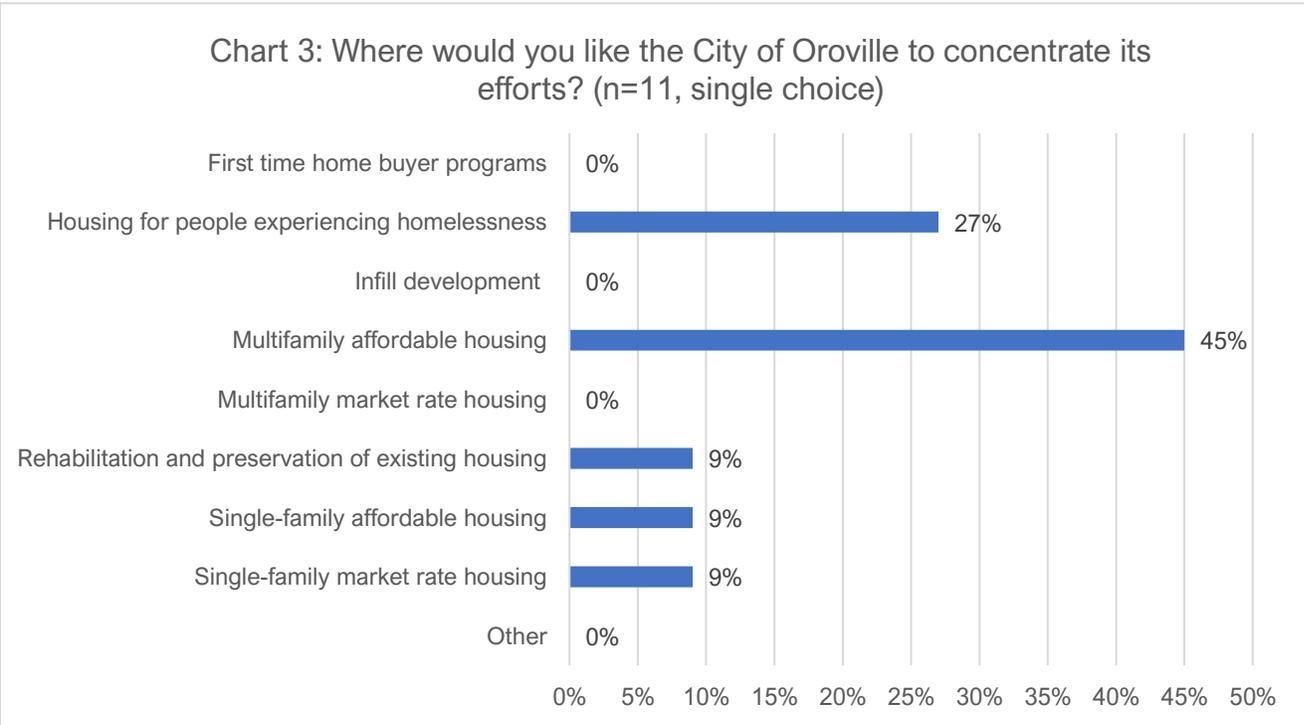

## APPENDIX D



## City of Oroville 2022 Housing Element Update

### Community Meeting #2: Housing Goals & Programs

#### Live Poll Results

November 17, 2021

Community members responded to trilingual polls in English, Spanish, and Hmong that were launched live during the meeting. Both the polls and community members' aggregated responses are provided below.

---

#### **Poll 1**

How did you hear about this event? / ¿Cómo se enteró de este evento? / Koj hnov peb lub koob tsheej no tau licas?

- a. City of Oroville Facebook / Página de Facebook de la Ciudad de Oroville / Lub nroog Oroville qhov Facebook
- b. Website – [www.orovalhoousingelement.com](http://www.orovalhoousingelement.com) / Sitio de Web – [www.orovalhoousingelement.com](http://www.orovalhoousingelement.com) / Lub Vasab [www.orovalhoousingelement.com](http://www.orovalhoousingelement.com)
- c. Email from Housing Tools / Email de Housing Tools / Email tuaj ntawm Housing Tools
- d. Local organization(s) / Organización(es) local(es) / Cov koomhaum nyob hauv zejzog
- e. Radio, news station, or newspaper / Radio, periódico, o estación de noticias / Xovtooj Cua, xovxwm thiab ntawv xovxwm
- f. Word of mouth / Me pasaron la voz / Qhia los ntawm neeg
- g. Other / Otro / Lwmyam

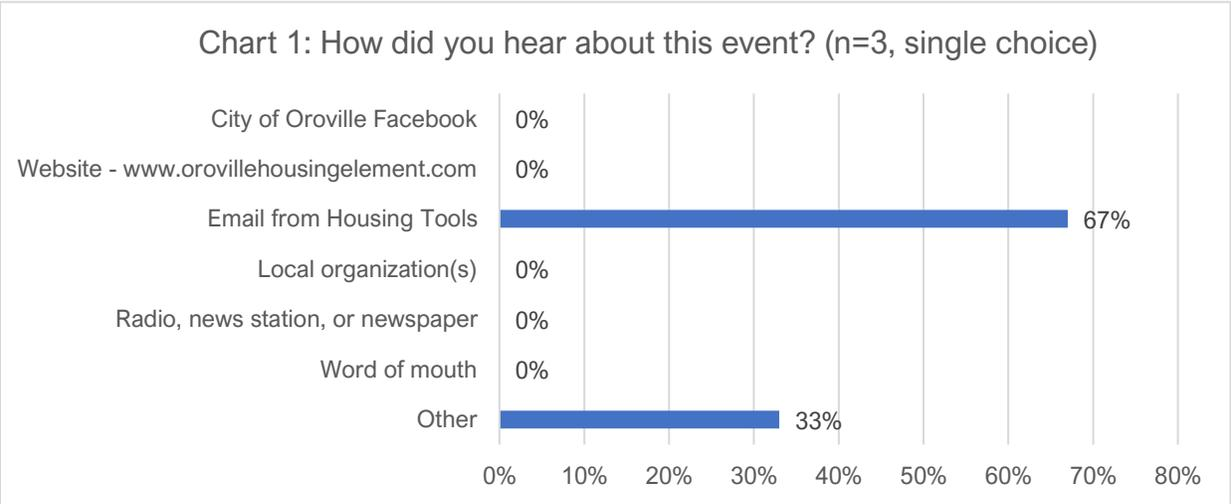

**Poll 2**

Did you participate in our first community meeting held October 20, 2021, or the online community survey? / ¿Participó en la primera reunión comunitaria el 20 de octubre de 2021, o en la encuesta comunitaria en línea? / Koj puas tuaj koom peb lub rooj sitham rau lub 10 hli tim 20, 2021 no thiab losis ua cov ntaubntawv tshuam xyuas lub zejzog nyob rau zaum huabcua thiab?

- a. Yes / Sí / Tau
- b. No / No / Tsis tau
- c. Unsure / No estoy seguro / Tsis paub

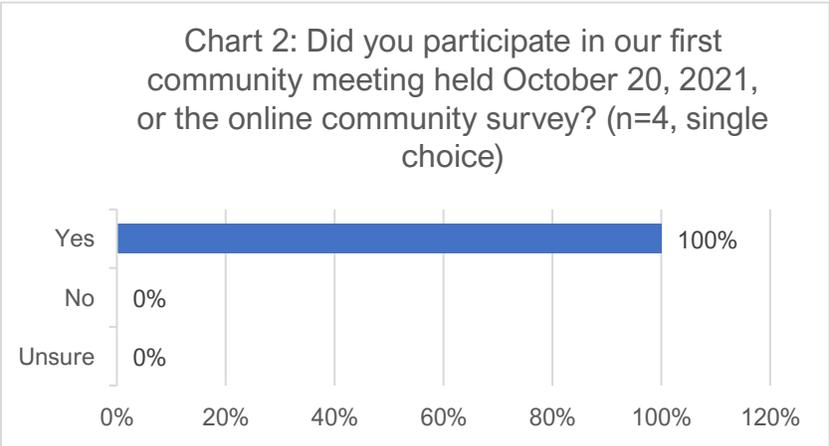

**Poll 3**

Did you find this community meeting beneficial? Please select all that apply. / ¿Le pareció servicial esta reunión comunitaria? Por favor seleccione todas las respuestas que correspondan. / Koj puas pom tau tias lub zejzog kev sibtham yeej pab tau thiab? Kos tagrho cov ua pab tau.

- a. Yes, I feel like my voice was heard and I was able to provide input into the Housing Element's development / Sí, siento que se escuchó mi voz y pude contribuir al desarrollo del Elemento de Vivienda. / Yog, kuv xav tias kuv cov suab yeej hnov thiab kuv yeej pab tau tswvyim rau Kev Tsimkho Vajtsev tseemceeb
- b. Yes, I learned new information and/or gained a greater degree of understanding about housing issues / Sí, obtuve nueva información y/o adquirí un mayor grado de comprensión sobre los problemas de vivienda. / Yog, kuv kawm tau yam tshiab thiab/losyog paub totau zoo heev txog teebmeem vajtsev.
- c. Yes, I was able to interact with other community members and learn about their ideas and perspectives / Sí, pude interactuar con otros miembros de la comunidad y conocer sus ideas y perspectivas. / Yog, kuv koom thiab kawm tau nrog rau lwm tus neeg nyob hauv zejzog cov tswvyim thiab kev xav.
- d. No, this was not beneficial to me / No, esto no me benefició. / Tsis, yeej pab tsis tau kuv li

Chart 3: Did you find this community meeting beneficial?  
(n=4, multiple choice)

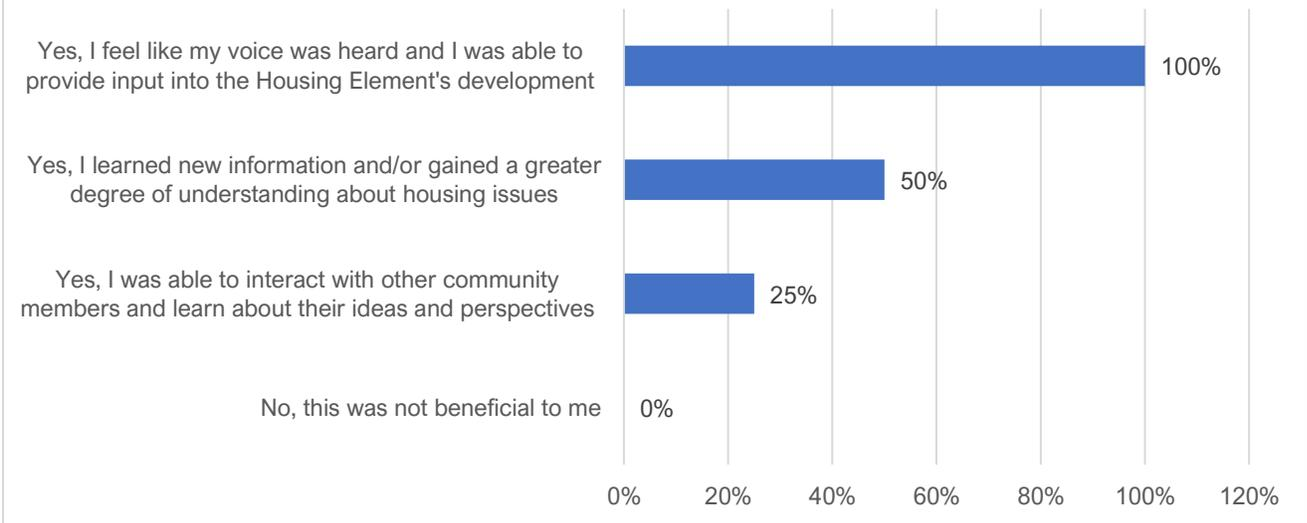

**RESOLUTION NO. P2022-08**

**A RESOLUTION OF INTENTION OF THE EPLANNING COMMISSION OF THE CITY OF OROVILLE RECOMMENDING THAT THE CITY COUNCIL ADOPT AND AUTHORIZE SUBMITTAL OF THE 2022-2030 HOUSING ELEMENT TO THE CALIFORNIA DEPARTMENT OF HOUSING AND COMMUNITY DEVELOPMENT (GPA 22-02).**

**WHEREAS**, safe and affordable housing for all persons is a goal of the City of Oroville (the “City”); and

**WHEREAS**, the Housing Element of the General Plan provides an opportunity for the City to demonstrate how this goal will be achieved; and

**WHEREAS**, the City is required by State law to prepare a Housing Element which provides information, policies, and programs to encourage the development of housing to meet the needs of all the City’s residents in conformance with State laws and regulations; and

**WHEREAS**, it has been determined that preparation and adoption of the 2022 Housing Element is exempt from environmental review pursuant to California Environmental Quality Act (CEQA) Section 15061(b)(3); and

**WHEREAS**, the Planning Commission conducted a public hearing on the Draft 2022 Housing Element on June 23, 2022.

**NOW, THEREFORE, BE IT RESOLVED THAT THE PLANNING COMMISSION RECOMMENDS THAT THE CITY COUNCIL OF THE CITY OF OROVILLE:**

1. Concur that preparation and adoption of the 2022 Housing Element is exempt from environmental review.
2. Hold a public hearing to consider and adopt the Draft 2022 Housing Element; and
3. Authorize staff to submit the Draft 2022 Housing Element to the State Department of Housing and Community Development for a review of up to 90 days.

**I HEREBY CERTIFY** that the foregoing resolution was duly introduced and passed at a regular meeting of the Planning Commission of the City of Oroville held on the 23 of June 2022, by the following vote:

AYES:

NOES:

ABSTAIN:

ABSENT:

ATTEST:

APPROVE:

\_\_\_\_\_  
JACKIE GLOVER, ASSISTANT CITY CLERK

\_\_\_\_\_  
CARL DURLING, CHAIRPERSON



# City of Oroville

## COMMUNITY DEVELOPMENT DEPARTMENT

1735 Montgomery Street  
 Oroville, CA 95965-4897  
 (530) 538-2430 FAX (530) 538-2426  
[www.cityoforoville.org](http://www.cityoforoville.org)

### NOTICE OF EXEMPTION

To: Butte County Clerk  
 25 County Center Drive  
 Oroville, CA 95965

From: City of Oroville  
 1735 Montgomery Street  
 Oroville, CA 95965

**Project Title: City of Oroville 2022-2030 Housing Element Update:** State law required that localities update their General Plan Housing Elements every eight years. The City of Oroville is updating its Housing Element to account for the 2022-2030 period.

**Project Location -Specific:** 2053 Montgomery Street  
 -City: City of Oroville  
 - County: Butte

**Description of Nature, Purpose, and beneficiaries of project:**  
Update of the City's 2022-2030 Housing Element to comply with State law.

**Name of Public Agency Approving Project:** City of Oroville

**Name of Person or Agency Carrying Out Project:** City of Oroville

Exempt Status (Check One):

- Ministerial (Sec. 21080(b)(1); 15268)  
 Declared Emergency (Sec. 21080(b)(3); 15269(a))  
 Emergency Project (Sec. 21080(b)(4); 15269(b)(c))  
 Categorical Exemption: State type & section number:  
     • General Rule Exemption; Title 14, CCR, §15061(b)(3)  
 Statutory Exemption: State code number:

**Reasons why project is exempt:** This action has been determined to be exempt from the California Environmental Quality Act (CEQA) review as follows:

*General Rule Exemption; Title 14, CCR, §15061(b)(3)*

The City of Oroville City Council has determined that this project is exempt from CEQA as it can be seen with certainty that there is no possibility that the proposed update would have a significant effect on the environment, as no changes to land use, density, policies and programs, or other changes that would result in an impact to the physical environment would occur with the adoption of the Housing element. Therefore, the project is exempt pursuant to CEQA Guidelines Section 15061(b)(3).

If filed by applicant:

1. Attach certified document of exemption finding.
2. Has a notice of exemption been filed by the public agency approving the project?  Yes  No

**Lead Agency Contact Person:** Wes Ervin, Principal Planner  
**Telephone:** (530) 538-2408

Signature: \_\_\_\_\_

Date: \_\_\_\_\_

- Signed by Lead Agency
- Signed by Applicant